



**giz** Deutsche Gesellschaft  
für Internationale  
Zusammenarbeit (GIZ) GmbH



# Reference Book on Building By-laws and Building Permit System

June, 2023

**Government of Nepal**

**Ministry of Federal Affairs and General Administration (MoFAGA)**

**Provincial and Local Governance Support Program (PLGSP)**

**Kathmandu, Nepal**

**Technical Support**

**GIZ/CDSG II**

**Technical Inputs**

**Sn. Er. Niyam Maharjan**

**Lalitpur**



**Government of Nepal**  
**Ministry of Federal Affairs and General Administration (MoFAGA)**  
**Provincial and Local Governance Support Program (PLGSP)**

**Reference Book on**  
**Building By-laws and Building Permit System**  
**June, 2023**



**GIZ/ CDSG II**  
**Khumaltar, Lalitpur**









## Executive Summary

The project Capacity Development Support to Governance (CDSG), led by the Ministry of Federal Affairs and General Administration (MoFAGA), aims to enhance the ability of local governments in Nepal to address the needs of disadvantaged groups and improve their access to public services. The technical assistance for the program is provided by the Deutsche Gesellschaft für Internationale Zusammenarbeit (GIZ) GmbH, commissioned by the German Federal Ministry for Economic Cooperation and Development (BMZ). As part of this project, a Resource Book on "Building By-laws and Building Permit System in Nepal" has been drafted with support from GIZ/CDSG, following a request from MoFAGA.

Urban planning and building by-laws are important in Nepal. They provide a structured approach to urban development, ensuring sustainable growth, efficient land use, and improved living conditions. Urban Planning helps in managing rapid urbanization, promoting balanced economic development, and addressing social and environmental challenges. By incorporating zoning regulations, Urban Planning ensures appropriate land allocation for residential, commercial, and recreational purposes, preventing haphazard construction and congestion. Building By-laws establish construction standards and safety guidelines, ensuring the structural integrity of buildings and the well-being of residents. They also contribute to disaster resilience by enforcing measures to withstand earthquakes and other natural hazards. Overall, Urban Planning and Building By-laws are crucial tools for creating resilient, well-functioning cities that enhance the quality of life for residents and promote sustainable development.

The Resource Book is designed to provide information on the Building By-laws and Building Permit System in Nepal, including details about the National Building Code and safer construction technologies. The book is structured into five chapters: Part I covers the Basic Building By-laws in Nepal, Part II focuses on the National Building Code System in Nepal, Part III provides an overview of the basics of the Building Permit System in Nepal, Part IV explores indigenous knowledge and technologies for safer buildings, and Part V discusses Environmental Impact Assessment in Nepal.

In the first part, Basic Building By-laws in Nepal, the book highlights the terminology, definition, and concept of building By-laws, as well as the basic criteria and provisions for land use zones and road classification. The second part, National Building Code System in Nepal, delves into the earthquake risk in Nepal, introduces the building code and its categories, and explains the legal provisions and implementation strategies at the local level. The third part, Basics of Building Permit System in Nepal, provides detailed procedures for building owners to follow when processing building permits in municipalities, including the application/registration process, building design requirements, and the flowchart of the building permit system.

The fourth part, Indigenous Knowledge, and Technologies for Safer Buildings, showcases indigenous architectures found in different regions of Nepal, such as the mountains, hills, and Terai, with a focus on the Kathmandu Valley. It identifies earthquake risk reduction technologies used in temples, palaces,

and residential buildings in the valley and provides tips for earthquake-resistant construction of reinforced concrete frame structures and load-bearing masonry structures, accompanied by sketches and details. Additionally, the chapter explains cost-effective construction technologies commonly practiced in Nepal for ordinary buildings. The fifth part provides general information about Brief Environmental Studies, Initial Environmental Examination, Environmental Impact Assessment, and the appendices include details about the Building Act, Building Regulations, Environment Protection Act, and a checklist for field inspections.

The resource book is intended to be a valuable tool for local governments in Nepal to adapt the Building By-laws and Building Code to suit their local context. It also serves as a comprehensive reference for educational institutions and other organizations interested in understanding the building permit system and safer construction practices in Nepal. Municipalities can utilize the contents of the reference book for conducting training and orientations, while technicians and practitioners can rely on it as a guidebook for designing and constructing residential buildings in municipalities.

## Table of Contents

<b>PART I: BASICS OF BUILDING BY-LAWS OF NEPAL</b> .....	<b>1</b>
<b>1.1 Preliminary</b> .....	<b>2</b>
<b>1.1.1 Some Terminologies in Urban Planning and Building By-laws</b> .....	<b>2</b>
<b>1.1.2 Measurements and Mathematical symbols used in Building By-laws</b> .....	<b>5</b>
<b>1.1.3 Responsibilities of Local Government in Building By-laws</b> .....	<b>7</b>
<b>1.1.4 Use of Building By-laws</b> .....	<b>12</b>
<b>1.1.5 Concept of Urban Planning</b> .....	<b>22</b>
<b>1.1.6 Concept of Building By-laws</b> .....	<b>27</b>
<b>1.2 Basic Building By-laws</b> .....	<b>30</b>
<b>1.2.1 Compound Wall</b> .....	<b>30</b>
<b>1.2.2 Rights of Way</b> .....	<b>37</b>
<b>1.2.3 Floor Area Ratio</b> .....	<b>39</b>
<b>1.2.4 Ground Coverage Ratio</b> .....	<b>42</b>
<b>1.2.5 Setback</b> .....	<b>44</b>
<b>1.2.6 Height of the Building</b> .....	<b>48</b>
<b>1.2.7 Septic Tank</b> .....	<b>51</b>
<b>1.2.8 Building Construction Near the River, Pond, and Well</b> .....	<b>55</b>
<b>1.2.9 Plotting of Land and Planning Permit</b> .....	<b>57</b>
<b>1.2.10 Miscellaneous</b> .....	<b>59</b>
<b>1.2.11 Planning By-laws and Land Use Zones</b> .....	<b>60</b>
<b>1.2.12 Road Construction</b> .....	<b>67</b>
<b>PART TWO: NATIONAL BUILDING CODE SYSTEM IN NEPAL</b> .....	<b>78</b>
<b>2.1 Earthquake Risk in Nepal</b> .....	<b>79</b>
<b>2.1.1 General Introduction</b> .....	<b>79</b>
<b>2.2 Introduction of National Building Code</b> .....	<b>84</b>

2.2.1 General Introduction .....	84
2.3 National Building Codes of Nepal .....	87
2.4 <i>Legal Provision and Act for the regulation of Building Constructions</i> .....	96
2.4.1 Structural Provision.....	96
2.4.2 Category of Nepal National Building Code .....	98
2.4.3 Strategy for Building Code implementation.....	101
<b><i>PART THREE: BASICS OF BUILDING PERMIT SYSTEM IN NEPAL</i></b> .....	109
<b>3.1 BUILDING PERMIT SYSTEM IN NEPAL</b> .....	110
3.1.1 Processes of Building Permission System .....	110
3.1.2 Stages of Building Permission System.....	113
<b><i>PART FOUR: INDIGENOUS KNOWLEDGE AND TECHNOLOGIES FOR SAFER BUILDINGS</i></b> .....	117
<b>4.1 Historical Background of Indigenous Knowledge and Technologies</b> .....	118
4.1.1 General Introduction .....	118
4.1.2 Indigenous Architecture of Hilly Region .....	128
4.1.3 Indigenous Architecture of Terai Region .....	134
4.1.4 Newari residential Buildings of Kathmandu Valley .....	140
4.1.5 Identification of different earthquake risk reduction technologies used in temple, palaces and residential Building of Kathmandu Valley .....	148
4.1.6 Tips for Earthquake Resistant Construction of RCC frame Structure Buildings .....	152
4.1.7 Tips for Construction of Earthquake Resistant Construction of Load Bearing Masonry Structure Residential Buildings up to three stories .....	159
<b>4.2 Cost Effective Construction Technologies</b> .....	163
4.2.1 Reinforced Hollow Concrete Masonry.....	163
4.2.2 Rat Trap Bond Brick Masonry.....	167
4.2.3 Compressed Stabilized Earthen Block (CSEB): .....	169

4.2.4 Stone-Crete Block (SCB) .....	173
<b><i>PART V: ENVIRONMENTAL IMPACT ASSESSMENT (EIA)</i></b> .....	<b>174</b>
<b><i>5.1 Brief Environmental Studies (BES) for Building Construction</i></b> .....	<b>175</b>
<b><i>5.2 Initial Environment Examination (IEE) for Building Constructions</i></b> .....	<b>176</b>
<b><i>5.3 Environment Impact Assessment (EIA) for Building Constructions</i></b> .....	<b>177</b>
<b><i>Appendices</i></b> .....	<b>182</b>
<b>Appendix I: The Building Act, 1999</b> .....	<b>182</b>
<b>Appendix II: The Building Regulation, 2009</b> .....	<b>190</b>
<b>Annex III: Submittals for getting Building permit</b> .....	<b>214</b>
<b>Annex IV: Checklist for Field Inspection</b> .....	<b>218</b>
<b><i>References</i></b> .....	<b>225</b>





## **PART I: BASICS OF BUILDING BY-LAWS OF NEPAL**

## 1.1 Preliminary

### 1.1.1 Some Terminologies in Urban Planning and Building By-laws

<b>Alteration</b>	:	Any change made, or proposed to be made, to the use, size, form, structural elements and external appearance of a building or structure.
<b>attic</b>	:	The space under the roof that could be used for a store, kitchen, living or prayer room except for sanitary use.
<b>balcony</b>	:	A portion of the building projected outside the wall with handrail or balustrade used for sitting or movement.
<b>Basement/cellar</b>	:	Any accessible and usable part of a building of which, at least, half of its room height is located below the finished ground level.
<b>Building</b>	:	An artificial construction, permanently fixed in or on the ground, enclosed by walls and a roof, for housing or enclosure or people or animals, the growing or storage of plants or the production, processing, storage or protection of any movable property.
<b>Building, accessory</b>	:	Such as private garages, garden sheds of a height not exceeding 3 meters shall be constructed up to plot's side and rear boundaries, provided the owners of the neighbouring plots agree to such buildings.
<b>Building, attached</b>	:	Two or more buildings which are mutually connected by each sharing one or two walls, either in part or full, with another building.
<b>Building, semi-attached</b>	:	Two adjoining buildings, sideways attached
<b>Building, detached</b>	:	Two or more adjoining buildings, free- standing buildings not having any mutual connection.
<b>Building line</b>	:	Generally used in closed frontage development, a line in which the façade of a building shall be placed as prescribed in a Local Zone Plan
<b>Building, residential</b>	:	A building that is arranged, designed, used and intended or built to be used for residential occupancy by one or more households or lodgers.
<b>Conservation</b>	:	conserve the existing situation of a Zone, building, construction, open spaces etc.
<b>Closed frontage</b>	:	The sideways attached construction of facades of adjoining buildings in one vertical plane
<b>Density</b>	:	The number of buildings, dwellings, households, people or the amount of floor space per unit of land Zone (e.g., per hectare) as the case may be and expressed as a numerical value
<b>Development</b>	:	The process of changing of intensifying the use of land through means of earthworks and/or construction works in, on, or above land or water
<b>Drainage</b>	:	The conduit or channel, built for the purpose of draining rain water, sewerage or used water.
<b>Easement</b>	:	A linear tract of land for the existing or future installation of public utility services, such as drains, water mains, sewers and cables, regardless of ownership of the land and of these utility services
<b>Acad</b>	:	The exterior wall of a building abutting a ROW

<b>Floor area</b>	:	The floor area is calculated on the basis of the external dimensions of buildings including all storeys, except floors entirely located below ground level, of any building. In calculating the floor area, secondary structures as balconies, attics, recessed balconies (loggias) or patios, enclosed porches and floor area devoted to accessory use shall be calculated. Any area constructed and used for vehicle parking or loading of vehicles shall not be included as floor areas.
<b>Floor Area Ratio</b>	:	It is the quotient of the total built or planned floor area on a plot and the total area of that plot. $\text{FAR} = \frac{\text{Total floor area in m}^2}{\text{Total ground plot area in m}^2}$
<b>Ground/Plot Coverage</b>	:	The Ground Coverage indicates how much percent the total ground/plot is permitted to be covered by buildings including accessory buildings. $\text{GC} = \left( \frac{\text{Built-up area of a plot at ground level in m}^2}{\text{Total ground or plot area in m}^2} \right) \times 100$
<b>Height of Building or construction</b>	:	The height of the building or construction from the average floor level to the top (highest) surface level with respect to the flat roof structure. The highest point of the building shall be measured at the mid-level, if the building has a sloped roof of 25- 30 degree. If the roof of a building has a sloped roof less than 25 degree, the highest point of the building shall be measured till the eaves.
<b>Land Use (Map)</b>	:	The purpose for which a tract of land, and any building or structure located there-on, is occupied and used, or is intended to be developed, occupied and used. Map: being a relevant document of this Bye-Law
<b>Lift</b>	:	A machine installed to facilitate movement of people or things from one floor to another.
<b>Local Area Plan</b>	:	A statutory plan, at least including a detailed land use plan and regulations, either being a ward, city centre, environment and heritage conservation, industry or development area based on complementing the provisions and regulations of this ordinance.
<b>Mezzanine floor</b>	:	The intermediate section of any two floors laying above the average floor level, used or built for the purpose of storage of materials.
<b>Monument</b>	:	It is broadly understood as a tangible expression of the people of special needs and tastes expressed in terms of buildings and objects of their conglomeration. It includes individual dwellings with high craftsmanship and architectural value, historic water tanks (Ponds/ Pokhari), waterspouts (Lohan Hiti), open shrines, public rest houses (Pati, Sattal), temples, priest houses, God houses etc. Any artificial object within municipality area of high preservation value due to its religious, architectural, archaeological, aesthetic, cultural, scientific, social etc. significance is understood to be a monument.
<b>Monument Site</b>	:	Is the defined topographical area in the proximity of a monument which is seen from and together with a protected monument in such a manner that

changes in the appearance of the area affect the appearance of the monument itself.

- Open space** : Public: streets, squares, ponds, rest places, parks etc.  
Private: open area left in a plot
- Open space, frontal** : The open empty space between the building line and of the plot in front of any building or construction and the border in the frontal side of the plot.
- Plinth** : The section of any building or construction above the level of the land surface.
- Plinth area** : The covered floor area, together with ground wall at the plinth level.
- Plot** : A surveyed and demarcated tract of land, duly registered by ownership and under a single title in the Cadastre and the Revenue Department of Municipality
- Plot subdivision** : Division of a tract of land, either into two or more parcels and/or plots
- Porch** : The access up to any building or construction (usually a low structure projecting from the doorway of a building and forming a covered entrance).
- Right of Way (ROW)** : A land corridor designated or constructed for the use of public access, vehicular traffic circulation and the location of public utilities, such as pathways, easements, roads and highways, regardless of the ownership of the land and utilities in the ROW
- Room Height** : The distance between the finished surface of the floor and the finished surface of the ceiling. When there is a tie beam, beam, plank, etc. in place of the finished ceiling, measurement has to be taken up to the lower surface of such tie beam, beam or plank. In the case of a sloping ceiling, the average height between the highest and the lowest part of the ceiling has to be taken.
- Setback line** : The line fixed by the concerned authority inside the plot, especially parallel to the borderline of the plot. No construction shall be allowed in the space between this line and the border of the plot. The outside wall shall be measured from the outer face of any structure, such as roof overhangs, eaves or balconies, projecting most outward from the wall
- storey** : The spatial portion of a building located between the surface of any floor above ground level and the surface of the floor next above it.
- Street / Road** : A wide way leading from one place to another, especially one with a specially prepared surface which vehicles can use.
- Street line** : The line that determines the outer limit of both sides of the street.

## 1.1.2 Measurements and Mathematical symbols used in Building By-laws

### Measurement

Quantity	Units	Symbol	Description
<b>Length</b>	Metre	m	1 metre = 100 centimetres (cm) 1 metre = 1000 millimetres (mm) 1 metre = 39.37 in = 3.2808 ft
	kilometre	km	1 kilometre = 1000 metres 1 kilometre = 0.6214 mile
	nautical mile		1 nautical mile = 1.15 miles
	Inch	in	1 inch = 2.540 cm
	centremetre	cm	1 cm = 0.3937 inch
	Foot	ft	1 foot = 30.48 cm
<b>Ropani</b>	-	-	1 Ropani = 5476 Sq.Ft
<b>Aana</b>	-	-	1 Ropani = 16 Aana 1 Aana = 342.25 Sq.Ft
<b>Paisa</b>	-	-	1 Paisa = 85.56 Sq.Ft
<b>Dam</b>	-	-	1 Dam = 21.39 Sq.Ft
<b>Mass</b>	kilogram	kg	1 kg = 1000 gram
	Pound	lb	1 kg = 2.2046 pound
	Tonne	t	1 tonne = 1000 kg
<b>Time</b>	Second	S	60 second = 1 minute 60 minute = 1 hour
<b>508.74 sq.m = 1 Ropani = 16 Aana = 5476 sq.ft</b>			
<b>31.79 sq.m = 1 Aana = 4 Paisa = 342.25 sq.ft</b>			
<b>7.94 sq.m = 1 Aana = 4 Dam = 85.56 sq.ft</b>			
<b>6772.41sq.m = 1 Bigha = 20 Katha = 72900 sq.ft</b>			
<b>338.62 sq/m = 1 Katha = 20 Dhur = 3645 sq.ft</b>			

### Some Mathematical Symbols

Equal to	=
Not equal to	$\neq$
Infinity	$\infty$
Approximately equal to	$\approx$
Smaller than or equal to	$\leq$
Larger than or equal to	$\geq$
Plus	+
Minus	-
Division	$\div$
Multiply	$\times$
Plus or minus	$\pm$
Sum	$\Sigma$
Approaches	$\rightarrow$

### 1.1.3 Responsibilities of Local Government in Building By-laws

#### 1. Overall Responsibilities of Local Government

#### The Local Government has the following responsibilities in building By-laws:

#### The Local Government has the following responsibilities in building By-laws:

**Formulating and implementing building By-laws:** Local governments are responsible for formulating and implementing building By-laws in their respective jurisdictions. These By-laws are designed to regulate the construction of buildings in order to ensure safety, security, and environmental sustainability.

**Issuing building permits:** Local governments are also responsible for issuing building permits. This is a process that ensures that all new buildings comply with the building By-laws.

**Inspecting buildings:** Local governments are responsible for inspecting buildings to ensure that they are in compliance with the building By-laws. This includes inspecting new buildings during construction and existing buildings on a regular basis.

**Enforcing building By-laws:** Local governments are responsible for enforcing the building By-laws. This means taking action against those who violate the By-laws, such as issuing fines or demolishing illegal buildings.

In addition to these responsibilities, local governments may also be involved in other aspects of building regulation, such as:

**Providing technical assistance to developers and builders:** Local governments can provide technical assistance to developers and builders to help them comply with the building By-laws. This can include providing information on the By-laws, reviewing building plans, and inspecting buildings during construction.

**Providing training to building inspectors:** Local governments can provide training to building inspectors to help them enforce the building By-laws. This training can cover topics such as building codes, inspection techniques, and enforcement procedures.

**Providing public education on building regulations:** Local governments can provide public education on building regulations to help residents understand the By-laws and their rights and responsibilities. This education can be provided through a variety of channels, such as print materials, public meetings, and online resources.

The responsibilities of local government in building By-laws are essential to ensuring the safety, security, and environmental sustainability of buildings in Nepal. By carrying out these responsibilities, local governments can help to create a more liveable and sustainable built environment.

### **Responsibilities of Local Government for improvement of slum area squatter settlement.**

The Local Government of Nepal has a number of responsibilities for the improvement of slum area squatter settlements. These responsibilities include:

**Planning and implementation:** Local governments are responsible for planning and implementing slum upgrading projects. This includes identifying the needs of the community, developing a plan, and securing funding.

**Service provision:** Local governments are also responsible for providing basic services to slum areas, such as water, sanitation, and waste management.

**Land tenure:** Local governments can play a role in regularizing the land tenure of slum dwellers. This can help to improve the security of tenure for slum dwellers and make it easier for them to access credit and other services.

**Capacity building:** Local governments can also provide capacity building to slum communities. This can help to improve the ability of communities to manage their own affairs and to advocate for their rights.

In addition to these responsibilities, local governments can also play a role in promoting awareness of the issue of slums and the importance of improving slum conditions. This can be done through public education campaigns and other outreach activities.

**The following are some of the specific provisions that local governments in Nepal are responsible for implementing in their slum upgrading projects:**

**Providing access to basic services:** Local governments must ensure that slum dwellers have access to basic services, such as water, sanitation, and waste management.

**Improving housing conditions:** Local governments must also improve the housing conditions of slum dwellers. This can include providing access to affordable housing, upgrading existing housing, and providing land tenure security.

**Creating employment opportunities:** Local governments can also create employment opportunities in slum areas. This can help to improve the economic conditions of slum dwellers and reduce poverty.

**Promoting social inclusion:** Local governments must also promote social inclusion in slum areas. This means ensuring that slum dwellers have access to education, healthcare, and other social services. By implementing these provisions, local governments can help to improve the lives of slum dwellers and make Nepal a more inclusive society.

### **Responsibilities of Local Government in protection and improvement of water resources such as water spouts, traditional wells, ponds and so on.**

The Local Government of Nepal has a number of responsibilities in the protection and improvement of water resources, such as water spouts, traditional wells, ponds, and so on. These responsibilities include:

**Planning and implementation:** Local governments are responsible for planning and implementing water resource management projects. This includes identifying the needs of the community, developing a plan, and securing funding.

**Regulation:** Local governments are responsible for regulating the use of water resources. This includes issuing permits for water use, monitoring water quality, and enforcing water conservation measures.



**Maintenance:** Local governments are responsible for maintaining water resources. This includes cleaning and repairing water spouts, wells, and ponds, and protecting them from pollution.

**Education:** Local governments can play a role in educating the public about the importance of water conservation and the need to protect water resources.

In addition to these responsibilities, local governments can also play a role in promoting awareness of the issue of water scarcity and the importance of water conservation. This can be done through public education campaigns and other outreach activities.

**The following are some of the specific provisions that local governments in Nepal are responsible for implementing in their water resource management projects:**

**Providing access to safe water:** Local governments must ensure that all citizens have access to safe water for drinking, cooking, and bathing.

**Protecting water quality:** Local governments must protect water quality by preventing pollution from industrial and agricultural activities.

**Conserving water:** Local governments must promote water conservation by educating the public about the importance of saving water.

**Reducing water wastage:** Local governments must reduce water wastage by repairing leaking pipes and improving water distribution systems.

By implementing these provisions, local governments can help to ensure that Nepal has a sustainable water supply for the future.

## **Responsibilities of Local Government in Land Development that include Guided Land Development (GLD) and land pooling**

The responsibilities of the local government regarding land development, including Guided Land Development (GLD) and land pooling are as follows:

### **Guided Land Development (GLD):**

Guided Land Development is a concept where the local government plays a proactive role in planning and implementing land development projects. The responsibilities of the local government in GLD may include:

**a. Land Use Planning:** The local government is responsible for developing land use plans that define how land should be utilized within their jurisdiction. This involves identifying suitable areas for various purposes such as residential, commercial, industrial, agricultural, recreational, etc.

**b. Infrastructure Development:** The local government is responsible for providing necessary infrastructure such as roads, water supply, sewage systems, electricity, etc., to support land development projects. This includes planning, designing, and implementing infrastructure projects in coordination with relevant agencies.

**c. Zoning and Regulation:** The local government establishes zoning regulations and land development guidelines to ensure orderly and sustainable development. This may include specifying setbacks, building height limits, density regulations, environmental protection measures, etc.

**d. Project Implementation:** The local government may directly undertake land development projects or facilitate private sector involvement through public-private partnerships. They oversee the implementation of GLD projects, ensuring compliance with regulations, quality standards, and timelines.

**e. Public Engagement:** The local government should engage with the public and stakeholders to gather inputs, address concerns, and ensure transparency in the GLD process. Public consultations, meetings, and feedback mechanisms may be established to involve the community in decision-making.

### **Land Pooling:**

Land pooling is a mechanism where multiple landowners voluntarily pool their individual land parcels for unified development. The local government's responsibilities in land pooling may include:

**a. Legal Framework:** The local government establishes the legal framework and regulations for land pooling, outlining the rights, obligations, and benefits for participating landowners.

**b. Facilitation and Coordination:** The local government facilitates the land pooling process by providing guidance, information, and assistance to landowners. They may coordinate with relevant agencies and stakeholders involved in infrastructure development, project planning, and implementation.

**c. Land Consolidation:** The local government oversees the consolidation of pooled land parcels to create larger development sites. This may involve surveying, demarcation, and reconstitution of land titles.

**d. Infrastructure Planning:** The local government collaborates with landowners and infrastructure providers to plan and design necessary infrastructure in pooled areas. They ensure that the infrastructure requirements of the developed land are met, such as road networks, utilities, public spaces, etc.

**e. Monitoring and Regulation:** The local government monitors the land pooling process to ensure compliance with the established regulations and timelines. They may conduct periodic inspections, reviews, and evaluations to assess the progress and quality of the development.

Here are some specific examples of how local governments in Nepal have implemented land development projects:

The Kathmandu Metropolitan City has implemented a number of land pooling projects to create new development areas.

The Lalitpur Metropolitan City has implemented a GLD project to develop a new commercial district. The Bhaktapur Municipality has implemented a number of land use planning and regulation initiatives to promote sustainable land development.

These are just a few examples of the many ways that local governments in Nepal are involved in land development. As Nepal continues to urbanize, the importance of local government involvement in land development will only increase.

## **Use of GIS and other available technology to keep records of municipal infrastructures and their use for maintenance purposes.**

Geographic information systems (GIS) and other available technologies can be used to keep records of municipal infrastructures in Nepal and use them for maintenance purposes. GIS can be used to store, manage, and analyse spatial data, such as the location of roads, bridges, water mains, and other infrastructure assets. This data can then be used to create maps and other visualizations that can help to identify problems with infrastructure, prioritize maintenance activities, and track the maintenance history of assets.

In addition to GIS, there are a number of other technologies that can be used to keep records of municipal infrastructures and use them for maintenance purposes. These include:

**Building information modelling (BIM):** BIM is a process that uses three-dimensional models to represent buildings and other infrastructure assets. BIM can be used to store information about the design, construction, and maintenance of assets, and it can be used to create simulations and visualizations that can help to identify problems and improve maintenance practices.

**Condition assessment:** Condition assessment is the process of evaluating the condition of infrastructure assets. This can be done through visual inspections, testing, and other methods. Condition assessment data can be used to prioritize maintenance activities and to track the condition of assets over time.

**Asset management software:** Asset management software can be used to store, manage, and analyze data about infrastructure assets. This software can help to track the location, condition, and maintenance history of assets, and it can be used to generate reports and visualizations that can help to improve maintenance practices.

By using these technologies, local governments can improve their ability to keep records of municipal infrastructures and use them for maintenance purposes. This can help to ensure that infrastructure assets are properly maintained and that they are able to function as intended.

## ***2. Responsibilities of Ward Offices***

**Ward Offices play a vital role in the implementation of building By-laws. They are responsible for a number of tasks, including:**

**Issuing building permits:** Ward Offices are responsible for issuing building permits. This process involves reviewing the design of a proposed building to ensure that it complies with the building By-laws.

**Inspecting construction sites:** Ward Offices are also responsible for inspecting construction sites to ensure that buildings are being constructed in accordance with the building By-laws.

**Taking action against violators:** Ward Offices can take action against violators of the building By-laws. This may include issuing fines, stopping construction, or even demolishing buildings that have been constructed illegally.

**Providing technical assistance:** Ward Offices can also provide technical assistance to property owners and builders. This assistance can help to ensure that buildings are constructed in a safe and compliant manner.

**Promoting awareness:** Ward Offices can also play a role in promoting awareness of building By-laws and the importance of complying with them. This can be done through public education campaigns and other outreach activities.

**The following are some of the specific provisions that Ward Offices in Nepal are responsible for enforcing in their building By-laws:**

**Building height and coverage:** Ward Offices must ensure that buildings do not exceed the maximum height or coverage limits set out in the By-laws.

**Setbacks:** Ward Offices must also ensure that buildings are set back from the property line by a certain distance. This helps to ensure that there is adequate space for ventilation and access.

**Materials:** Ward Offices must ensure that buildings are constructed using materials that are appropriate for the climate and the seismic risks in the area.

**Fire safety:** Ward Offices must ensure that buildings meet the minimum standards of fire safety. This includes having adequate fire escapes and fire suppression systems.

**Disability access:** Ward Offices must ensure that buildings are accessible to people with disabilities. This includes having ramps, wide doorways, and accessible toilets.

By enforcing these provisions, Ward Offices can help to ensure that buildings are safe, structurally sound, and accessible to everyone.

**Here are some of the challenges that Ward Offices in Nepal face in implementing building By-laws:**

**Lack of resources:** Ward Offices often lack the resources to effectively enforce building By-laws. This includes a lack of staff, a lack of funding, and a lack of technical expertise.

**Corruption:** Corruption is also a challenge in implementing building By-laws. This can involve builders bribing officials to overlook violations or officials turning a blind eye to violations in exchange for favors.

**Public apathy:** Public apathy is another challenge. Many people are not aware of the building By-laws or they do not care about complying with them. This can make it difficult for Ward Offices to enforce the By-laws.

Despite these challenges, Ward Offices play an important role in ensuring the safety of buildings in the country. By continuing to work to implement building By-laws, Ward Offices can help to prevent accidents and save lives.

#### **1.1.4 Use of Building By-laws**

##### ***1. Basic Standards on Settlement Development, Urban Planning & Building Construction 2072***

- 1) Basic Standards on Settlement Development, Urban Planning & Building Construction 2072 is Nepal's main National Building By-law in Nepal. The Government of Nepal approved this By-law on 30 September 2015 and published in Nepal Gazette on 8 April

2016. This By-laws was amended and published in Nepal Gazette on 10 April 2017. Local governments cannot make weaker By-laws than this.

- 2) If any local government has already applied stronger By-laws than the National Building By-laws, the local one will prevail.
- 3) Local government cannot make weaker By-laws than the current one for any reason. This document can be downloaded from <https://www.moud.gov.np/storage/listies/July2019/Basti-Bikash-Mapdanda-2072-Final.pdf>.

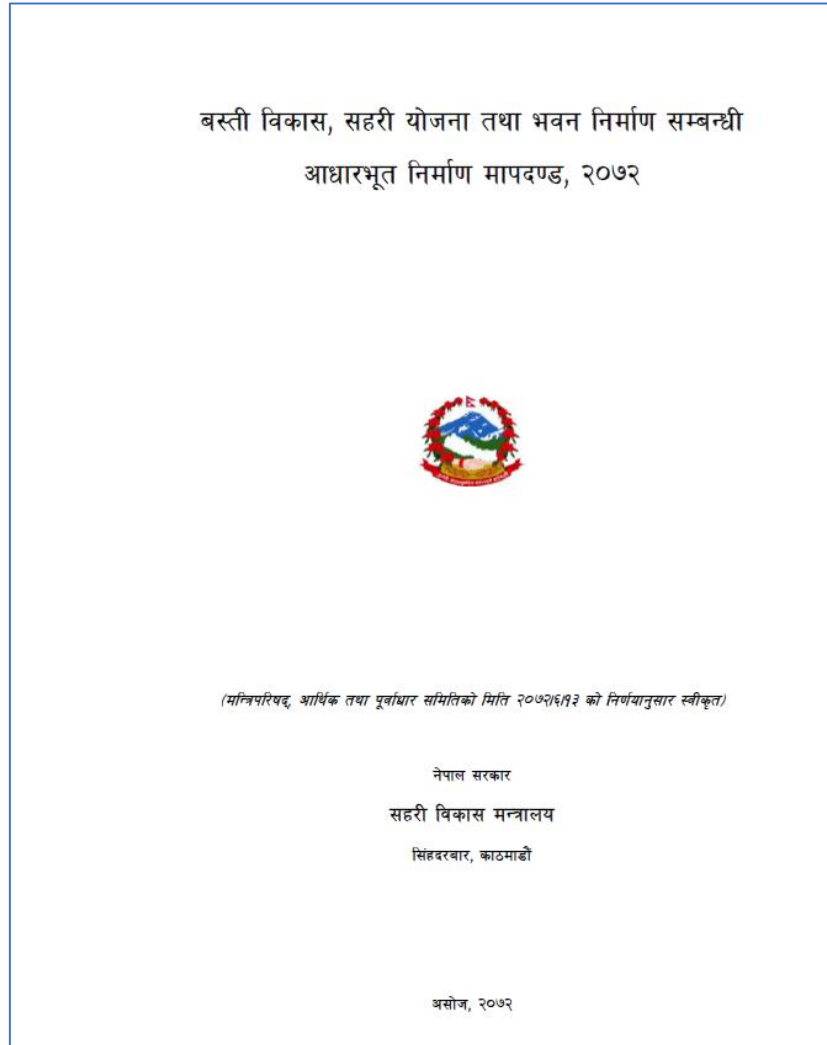

## **Background, usefulness and contents of "basic standards on settlement Development, Urban Planning and building, 2072.**

The Basic Standards on Settlement Development, Urban Planning and Building, 2072 of Nepal (also known as the Basic Standards) are a set of guidelines that provide minimum standards for the development of settlements, urban planning, and building in Nepal. The Basic Standards were developed in response to the need for a comprehensive set of guidelines that would help to ensure the safety, sustainability, and livability of settlements in Nepal.

### **The Basic Standards are divided into three sections:**

**Settlement Development:** This section provides guidelines for the development of new settlements and the expansion of existing settlements. The guidelines cover a wide range of topics, including land use, infrastructure, and environmental protection.

**Urban Planning:** This section provides guidelines for the planning of urban areas. The guidelines cover a wide range of topics, including land use, transportation, and public spaces.

**Building:** This section provides guidelines for the construction of buildings. The guidelines cover a wide range of topics, including materials, design, and construction methods.

The Basic Standards are useful for a variety of stakeholders, including:

**Government officials:** The Basic Standards can be used by government officials to develop and implement policies and regulations related to settlement development, urban planning, and building.

**Planners:** The Basic Standards can be used by planners to develop plans for new settlements and the expansion of existing settlements.

**Builders:** The Basic Standards can be used by builders to ensure that their buildings meet the minimum standards for safety, sustainability, and livability.

**The general public:** The Basic Standards can be used by the general public to learn about the minimum standards for settlement development, urban planning, and building.

The Basic Standards are a valuable resource for anyone who is involved in the development, planning, or construction of settlements in Nepal. The guidelines provide a comprehensive set of standards that can help to ensure the safety, sustainability, and livability of settlements in Nepal.

Here are some of the specific contents of the Basic Standards:

**Settlement Development:** The section on settlement development includes guidelines on land use, infrastructure, and environmental protection. For example, the guidelines specify that settlements should be located in areas that are not prone to natural disasters, and that they should have access to adequate water and sanitation facilities.

**Urban Planning:** The section on urban planning includes guidelines on land use, transportation, and public spaces. For example, the guidelines specify that urban areas should have a mix of land uses, that they should be well-connected by transportation networks, and that they should have adequate public spaces.

**Building:** The section on building includes guidelines on materials, design, and construction methods. For example, the guidelines specify that buildings should be constructed using earthquake-resistant

materials, that they should have adequate ventilation and lighting, and that they should be accessible to people with disabilities.

The Basic Standards are a living document that is subject to revision as needed. The Ministry of Urban Development is responsible for updating the Basic Standards as necessary.

## 2. *Building By-laws for Kathmandu Valley, 2064*

- 1) The Government of Nepal approved Building By-laws for the Construction in Kathmandu Valley, 2064 on first May 2007 effective from 15<sup>th</sup> May 2007. The Government of Nepal amended this By-laws was amended by the on 16<sup>th</sup> November 2008 and 28<sup>th</sup> June 2010. However, when conflict arises on the provision between National Building By-laws and this Bye-law, the provision of National Building By-laws will prevail.
- 2) If any provision of Kathmandu Valley Building By-laws, 2064 is stronger , than the National Building By-laws, the stronger provision will be applied .
- 3) An Electronic copy of Kathmandu Valley Building By-laws can be downloaded from <http://www.kvda.gov.np/form/criteria>

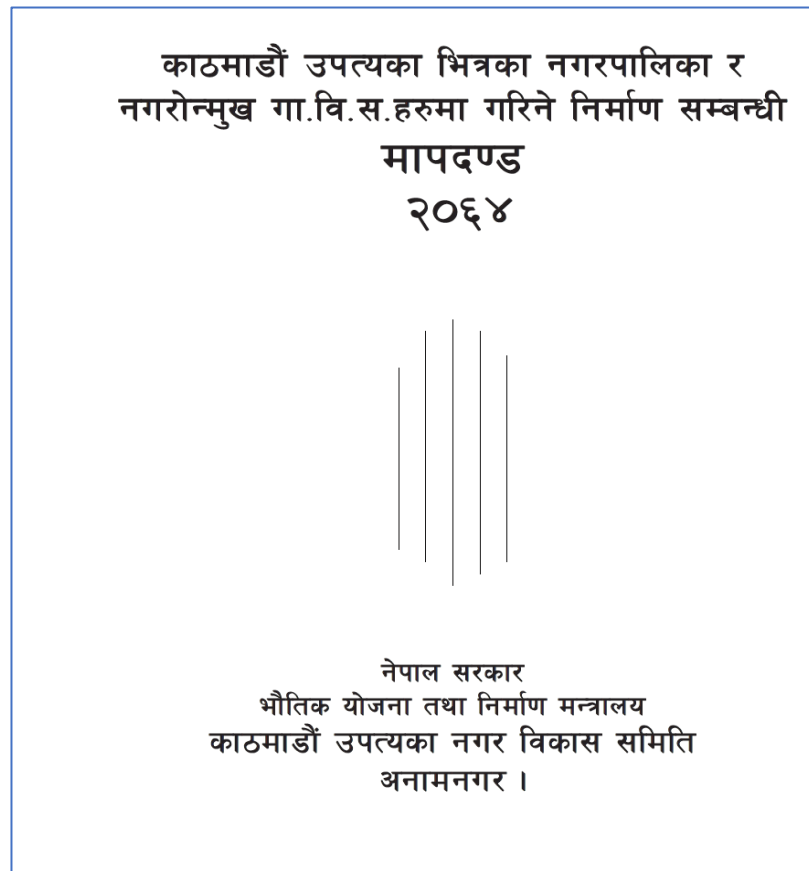

The Building By-laws for Kathmandu Valley, 2064 (2007) are a set of regulations governing the construction of buildings in the Kathmandu Valley. The By-laws were developed by the Kathmandu Valley Town Development Committee (KVTDC) in response to the need for a comprehensive set of regulations that would help to ensure the safety and sustainability of buildings in the valley.

The Building By-laws are divided into three parts:

Part I: General Provisions

Part II: Building Requirements

Part III: Enforcement

Part I of the By-laws sets out the general provisions that apply to all buildings in the Kathmandu Valley. These provisions include requirements for the minimum size of plots, the maximum height of buildings, and the use of earthquake-resistant materials.

Part II of the By-laws sets out the specific requirements for different types of buildings. These requirements include requirements for the size and location of rooms, the type of materials that can be used, and the fire safety standards that must be met.

Part III of the By-laws sets out the procedures for enforcing the By-laws. These procedures include the issuance of building permits, the inspection of buildings, and the taking of action against violators.

The Building By-laws for Kathmandu Valley, 2064 are a comprehensive set of regulations that help to ensure the safety and sustainability of buildings in the valley. The By-laws are regularly updated to reflect changes in the construction industry and the seismic risks in the region.

Here are some of the key features of the Building By-laws for Kathmandu Valley, 2064:

They are based on the principles of seismic safety. The By-laws require that buildings in the Kathmandu Valley be constructed using earthquake-resistant materials and methods.

They are comprehensive. The By-laws cover a wide range of topics, including the size and location of rooms, the type of materials that can be used, and the fire safety standards that must be met.

They are regularly updated. The By-laws are regularly updated to reflect changes in the construction industry and the seismic risks in the region.

The Building By-laws for Kathmandu Valley, 2064 are an essential tool for ensuring the safety and sustainability of buildings in the valley. The By-laws help to protect the lives of residents and visitors, and they help to reduce the risk of damage to property during earthquakes.



### 3. *Model By-laws for Building Construction, 2071*

- 1) Model By-laws for building construction can be applied to any provision on which the National Building By-laws are silent. This can be the reference document for making local Building By-laws but the local government cannot pass weaker provisions than these By-laws.
- 2) If any inconsistencies arise between Model Building By-laws and National Building By-laws, the National Building By-laws prevails. These By-laws can be downloaded from <https://www.moud.gov.np/storage/listies/July2019/Bhawan-Nirman-2071.pdf>.



#### **Short description of the background, usefulness, and contents of the Model By-laws for Building Construction, 2071 of Nepal:**

##### **Background:**

The Model By-laws for Building Construction, 2071 (2014) were developed by the Ministry of Urban Development (MoUD) in response to the need for a comprehensive set of By-laws that would help to ensure the safety and sustainability of buildings in Nepal. The By-laws were based on the Building By-laws for Kathmandu Valley, 2064, as well as international standards and best practices.

##### **Usefulness:**

The Model By-laws are useful for a variety of stakeholders, including:

Government officials: The Model By-laws can be used by government officials to develop and implement policies and regulations related to building construction.

**Planners:** The Model By-laws can be used by planners to develop plans for new buildings and the expansion of existing buildings.

**Builders:** The Model By-laws can be used by builders to ensure that their buildings meet the minimum standards for safety, sustainability, and livability.

**The general public:** The Model By-laws can be used by the general public to learn about the minimum standards for building construction.

Contents: The Model By-laws are divided into 10 chapters:

Chapter 1: General Provisions

Chapter 2: Site Planning and Development

Chapter 3: Materials

Chapter 4: Design

Chapter 5: Construction

Chapter 6: Inspection

Chapter 7: Maintenance

Chapter 8: Fire Safety

Chapter 9: Accessibility

Chapter 10: Enforcement

The Model By-laws cover a wide range of topics related to building construction, including site planning and development, materials, design, construction, inspection, maintenance, fire safety, accessibility, and enforcement. The By-laws are based on the principles of seismic safety, sustainability, and livability. The Model By-laws are a living document that is subject to revision as needed. The MoUD is responsible for updating the Model By-laws as necessary.

#### 4. *Sectoral By-laws for Building Construction*

- 1) There are sector-specific By-laws for building construction. Local government should use these By-laws to permit sector specific buildings and construction in certain areas.

Name of By-laws	Use	Agencies
By-laws on petrol pump, 2064	For the construction of buildings related to petrol pump	Nepal Oil Corporation
By-laws on constructing building near the airport	Construction building near the airport	Nepal Civil Aviation Authority
Electricity	For installing electricity in building	Nepal Electricity Authority

Short Description about the "Sectoral By-laws for Building Construction" in Nepal.

The Sectoral By-laws for Building Construction in Nepal are a set of regulations that govern the construction of specific types of buildings in the country. The By-laws are issued by the Ministry of Urban Development (MoUD) and are based on the Model By-laws for Building Construction, 2071.

The Sectoral By-laws cover a wide range of building types, including:

**Educational buildings:** These buildings must meet the minimum standards for safety, accessibility, and livability. They must also have adequate fire safety measures in place.

**Healthcare buildings:** These buildings must meet the minimum standards for safety, accessibility, and livability. They must also have adequate fire safety measures in place.

**Hotels and restaurants:** These buildings must meet the minimum standards for safety, accessibility, and livability. They must also have adequate fire safety measures in place.

**Industrial buildings:** These buildings must meet the minimum standards for safety, accessibility, and livability. They must also have adequate fire safety measures in place.

**Commercial buildings:** These buildings must meet the minimum standards for safety, accessibility, and livability. They must also have adequate fire safety measures in place.

The Sectoral By-laws are a comprehensive set of regulations that help to ensure the safety and sustainability of specific types of buildings in Nepal. The By-laws are regularly updated to reflect changes in the construction industry and the seismic risks in the region.

#### **Here are some of the key features of the Sectoral By-laws for Building Construction:**

They are based on the principles of seismic safety. The By-laws require that buildings in Nepal be constructed using earthquake-resistant materials and methods.

They are comprehensive. The By-laws cover a wide range of topics, including the size and location of rooms, the type of materials that can be used, and the fire safety standards that must be met.

They are regularly updated. The By-laws are regularly updated to reflect changes in the construction industry and the seismic risks in the region.

The Sectoral By-laws for Building Construction are an essential tool for ensuring the safety and sustainability of specific types of buildings in Nepal. The By-laws help to protect the lives of residents and visitors, and they help to reduce the risk of damage to property during earthquakes.

The Sectoral By-laws for Building Construction in Nepal are published by the Department of Urban Development and Building Construction (DUDBC) of the Ministry of Urban Development (MOUD).

The By-laws are available on the DUDBC website: <https://dudbc.gov.np/>

The By-laws are divided into 10 sectors:

- **Setback and Coverage:** These By-laws regulate the minimum setback and maximum coverage of buildings.
- **Height and Bulk:** These By-laws regulate the maximum height and bulk of buildings.
- **Architectural Design:** These By-laws regulate the architectural design of buildings, including the size and placement of windows, doors, and balconies.
- **Structural Design:** These By-laws regulate the structural design of buildings, including the materials that can be used and the strength of the foundation.

- **Fire Safety:** These By-laws regulate the fire safety of buildings, including the installation of fire alarms and sprinklers.
- **Sanitary Facilities:** These By-laws regulate the sanitary facilities of buildings, including the number and size of toilets and bathrooms.
- **Electrical Installations:** These By-laws regulate the electrical installations of buildings, including the type of wiring and the number of outlets.
- **Mechanical Installations:** These By-laws regulate the mechanical installations of buildings, including the type of heating and cooling systems.
- **Accessibility:** These By-laws regulate the accessibility of buildings for people with disabilities.
- **Other Requirements:** These By-laws regulate other aspects of building construction, such as the use of recycled materials and the protection of the environment.

## 5. Required Technical Human Resources for Local Government for Building Construction and Enforcing National Building Codes

General information on the required human resources for local government in Nepal for building construction and enforcing the National Building Code (NBC).

### **Building Construction:**

Local governments typically require human resources with expertise in various aspects of building construction. This may include professionals in the fields of architecture, civil engineering, urban planning, and construction management. The specific roles and responsibilities can vary depending on the size and capacity of the local government. Some key positions may include:

**Municipal Engineer:** Responsible for overseeing building construction activities, reviewing building plans, ensuring compliance with building codes and regulations, conducting inspections, and issuing construction permits.

**Building Inspectors:** Responsible for inspecting construction sites at different stages to ensure adherence to approved plans, building codes, and safety standards.

**Architects and Urban Planners:** Involved in the design review process, assessing building plans for compliance with aesthetic, functional, and urban planning requirements.

**Civil Engineers:** Provide technical expertise in structural design, site engineering, and construction management.

**Surveyors:** Conduct land surveys, demarcation, and verification of property boundaries.

**Support Staff:** Administrative personnel, clerks, and data entry operators to manage documentation, record-keeping, and coordination tasks.

### **Enforcing the National Building Code (NBC):**

The National Building Code of Nepal provides guidelines and standards for safe and sustainable building construction. Local governments play a crucial role in enforcing the NBC within their jurisdictions. The required human resources for enforcing the NBC can include:

**Building Code Inspectors:** Responsible for conducting inspections of new and existing buildings to ensure compliance with the provisions of the NBC.

**Code Compliance Officers:** Monitor and enforce adherence to the NBC, conduct site visits, and address violations or non-compliance.

**Planning and Development Officers:** Provide technical assistance and guidance to builders, architects, and engineers regarding compliance with the NBC.

**Legal and Enforcement Officers:** Handle legal aspects, issue notices, and take appropriate action in case of non-compliance with the NBC.

**Training and Education Specialists:** Conduct awareness programs, training sessions, and workshops to educate stakeholders on the provisions of the NBC and promote compliance.

**Specialized engineers like Geomatics:** Handle modern survey tools and digital mapping works.

**Landscape architects:** Responsible for giving proper shape to our open spaces/public parks according to the local ecology of the municipalities.

The Minimum number of required technical Human Resources for building construction and enforcing National Building Codes are tabulated as follows:

Local Level	Minimum Number of Required Technical Human Resources
<b>Rural Municipalities</b>	Architect -1 Civil Engineer-1 Overseer-1 Surveyor-1
<b>Small Sized Municipalities</b>	Architect -1 Civil Engineer-1 -Overseer-1 Surveyor-1
<b>Medium Sized Municipalities</b>	Structural Engineer-1 Urban Planner -1 Civil Engineer-1 Architect-1 Overseer-1 Surveyor-1
<b>Metropolitan and Sub-metropolitan</b>	Geo-Technical Engineer-1 Structural Engineer-1 Urban Planner -1 Civil Engineer-1 Architect-1 Overseer-1 Surveyor-1
<b>Note: Engineers and Architects should be registered at Nepal Engineering Council</b>	

**Source: MOFAGA**

## **1.1.5 Concept of Urban Planning**

### **Background of Urban Planning of Nepal**

Urban planning in Nepal has been a crucial aspect of the country's development strategy. With rapid urbanization and population growth, Nepal has faced numerous challenges related to urban infrastructure, housing, transportation, and environmental sustainability. The government of Nepal, in collaboration with various agencies and organizations, has been actively involved in urban planning and implementing ongoing activities to address these challenges.

#### **National Urban Development Strategy (NUDS):**

The National Urban Development Strategy (NUDS) was formulated in 2017 to provide a long-term vision and strategic framework for urban development in Nepal. The strategy focuses on inclusive, sustainable, and resilient urban development. It emphasizes the integration of social, economic, and environmental dimensions in urban planning and management.

#### **Urbanization and City Governance Programme (UNCG):**

The Urbanization and City Governance Programme (UNCG) is a major ongoing initiative in Nepal. It is implemented by the Ministry of Urban Development in partnership with the World Bank and other development partners. UNCG aims to strengthen urban governance, improve urban infrastructure and services, and enhance the capacity of municipalities for effective urban planning and management.

#### **Integrated Settlement Development Programme (ISDP):**

The Integrated Settlement Development Programme (ISDP) is an ongoing initiative implemented by the Ministry of Land Management, Cooperatives and Poverty Alleviation. It focuses on upgrading and developing informal settlements, providing basic infrastructure and services, and ensuring tenure security for the urban poor.

#### **Urban Housing Reconstruction Programme (UHRP):**

The Urban Housing Reconstruction Programme (UHRP) was initiated after the devastating earthquakes of 2015, which severely damaged housing infrastructure in several urban areas of Nepal. The program aims to support the reconstruction of earthquake-resistant houses and improve the overall housing conditions in affected urban areas.

#### **Urban Transport Master Plan (UTMP):**

The Urban Transport Master Plan (UTMP) is being developed to address the growing challenges of urban transportation in Nepal. The plan focuses on developing efficient and sustainable transport systems, promoting public transportation, improving road safety, and integrating land use and transport planning.

#### **Urban Environment Management Society (UEMS):**

The Urban Environment Management Society (UEMS) is a non-governmental organization that works in the field of urban environmental planning and management. It promotes sustainable urban development practices, waste management, environmental conservation, and awareness among urban residents.

These are some of the ongoing activities and initiatives in urban planning in Nepal. The government, along with various development partners and organizations, continues to work towards sustainable urban development, improved infrastructure, and enhanced quality of life in urban areas.

## **Different types of Urban Plans that are adopted and Type of ongoing urban plans in Nepal**

In Nepal, various urban plans are adopted and implemented to guide the development and management of cities and urban areas. Here are some types of urban plans commonly used:

**Integrated Development Plan:** Integrated development plans aim to holistically address the social, economic, and physical aspects of urban areas. These plans focus on coordinating and integrating various sectors such as land use, transportation, housing, infrastructure, environment, and social services.

**Master Plan:** Master plans, also known as comprehensive development plans or city development plans, provide a long-term vision and framework for the overall development and growth of a city or urban area. They include strategies, policies, and guidelines for land use, transportation, infrastructure, environment, and socio-economic development.

**Land Use Plan:** Land use plans define the allocation and regulation of land for different purposes within a city or urban area. These plans determine areas for residential, commercial, industrial, recreational, and public facilities, as well as open spaces and conservation areas.

**Transportation and Mobility Plan:** Transportation plans focus on improving transportation systems, infrastructure, and mobility within urban areas. They include strategies for road networks, public transportation, pedestrian and cycling infrastructure, traffic management, and parking facilities.

**Housing and Settlement Plan:** Housing plans aim to address housing needs and promote adequate and affordable housing options within urban areas. These plans include strategies for housing development, slum upgrading, housing finance, and policies to address homelessness and housing affordability.

**Urban Conservation Plan:** Urban conservation plans aim to preserve and protect the cultural and historical heritage of cities and urban areas. These plans include strategies for the conservation and adaptive reuse of historic buildings, archaeological sites, traditional neighborhoods, and cultural landscapes.

**Disaster Risk Reduction and Resilience Plan:** Given Nepal's vulnerability to natural disasters, disaster risk reduction plans focus on minimizing risks and building resilience in urban areas. These

plans include strategies for hazard mapping, early warning systems, infrastructure resilience, and community-based disaster preparedness.

Some ongoing urban plans and initiatives in Nepal include:

**Kathmandu Valley Development Authority (KVDA) Master Plan:** The KVDA is responsible for the development and management of the Kathmandu Valley, and they are currently working on a revised master plan to address the urban growth, transportation, and infrastructure challenges in the valley.

**Bagmati Integrated Development Plan:** The Bagmati Integrated Development Project focuses on the revitalization and sustainable development of the Bagmati River corridor and its surroundings. The plan aims to improve water quality, manage solid waste, develop recreational spaces, and enhance the overall environment.

**Urban Governance and Infrastructure Improvement Project (UGIIP):** UGIIP is a government project that aims to strengthen urban governance and improve infrastructure in selected municipalities across Nepal. It includes various components such as urban planning, infrastructure development, capacity building, and institutional reforms.

**Urban Water Supply and Sanitation Project:** This ongoing project focuses on improving access to safe drinking water and sanitation facilities in urban areas. It includes infrastructure development, capacity building, and community awareness programs.

## **Role and use of building byelaws in planned urban development**

Building By-laws play a crucial role in planned urban development. They are a set of regulations, guidelines, and standards that govern the design, construction, and use of buildings within a city or municipality. The role and use of building By-laws in planned urban development are as follows:

**Ensuring Safety and Structural Integrity:** Building By-laws set standards for structural design, materials, and construction practices. They ensure that buildings are constructed in a safe and structurally sound manner, minimizing the risk of collapse or damage during natural disasters such as earthquakes, floods, or landslides.

**Regulating Land Use and Zoning:** Building By-laws define the permissible land uses and zoning regulations within urban areas. They determine the type of activities allowed in specific areas, such as residential, commercial, industrial, or mixed-use zones. By regulating land use, By-laws help maintain a balanced and organized urban environment.

**Promoting Aesthetic and Architectural Standards:** Building By-laws often include guidelines for architectural design, building aesthetics, and urban character. They may specify parameters related to building height, setback distances, façade design, building materials, and landscaping. These standards help create visually appealing and harmonious urban landscapes.

**Ensuring Adequate Infrastructure:** Building By-laws address infrastructure requirements related to water supply, sanitation, drainage, electricity, and road access. They ensure that new buildings comply



with the necessary infrastructure provisions and do not place an undue burden on the existing infrastructure network.

**Enhancing Accessibility and Universal Design:** By-laws may include provisions for accessibility and universal design, ensuring that buildings are accessible to persons with disabilities. This may involve requirements for ramps, elevators, accessible parking, and other accessibility features to promote inclusivity.

**Addressing Environmental Sustainability:** Building By-laws increasingly incorporate provisions for environmental sustainability. They may include requirements for energy efficiency, water conservation, waste management, green building practices, and the use of renewable energy sources. These provisions promote environmentally responsible urban development.

**Facilitating Urban Planning and Development Control:** Building By-laws are an essential tool for urban planning and development control. They provide a framework for regulating building construction and development activities, ensuring that they align with the broader urban development plans and objectives of the city or municipality.

**Ensuring Compliance and Enforcement:** Building By-laws establish the legal framework for compliance and enforcement. They define the procedures for obtaining building permits, inspections, and approvals. By-laws also outline penalties for non-compliance and provide mechanisms for resolving disputes related to building construction and use.

Overall, building By-laws serve as a crucial instrument for promoting planned urban development. They help create safe, sustainable, and well-organized urban environments, ensuring that buildings and their surroundings are designed and constructed in a manner that meets the needs of residents while considering the broader urban planning goals and objectives.

### **Role and use of building-byelaws in planned urban development with an examples of ongoing activities from related agencies**

Building By-laws play a vital role in planned urban development by providing regulations and guidelines for the design, construction, and use of buildings. Several agencies and organizations are involved in implementing and enforcing building By-laws to promote planned urban development. Here are some examples of ongoing activities by related agencies:

#### **Kathmandu Valley Development Authority (KVDA):**

KVDA has been actively involved in developing and implementing building By-laws to regulate construction activities in the Kathmandu Valley.

The authority has been working on revising the existing building By-laws to address the challenges of rapid urbanization, ensuring safety standards, and promoting sustainable urban development.

#### **Department of Urban Development and Building Construction (DUDBC):**

DUDBC is a government agency responsible for urban development and building construction across Nepal. The department plays a crucial role in formulating and enforcing building By-laws at the national level, ensuring compliance with safety, structural, and environmental standards.

### **Kathmandu Metropolitan City (KMC):**

KMC, as the local governing body of Kathmandu, is actively involved in implementing building By-laws and regulating construction activities within its jurisdiction.

The city conducts regular inspections to ensure compliance with building By-laws and takes necessary actions against violations.

### **Lalitpur Metropolitan City (LMC):**

LMC, which governs Lalitpur city, has been focusing on planned urban development through the implementation of building By-laws.

The municipality enforces building codes and regulations to ensure safe and sustainable construction practices.

### **Bhaktapur Municipality:**

Bhaktapur Municipality has been working on enforcing building By-laws to regulate construction activities in the historic city of Bhaktapur.

The municipality focuses on preserving the cultural heritage of Bhaktapur while ensuring that new constructions comply with safety and aesthetic standards.

### **Building Codes and Standards Division (BCSD):**

BCSD, under the Ministry of Urban Development, is responsible for formulating and updating building codes, standards, and guidelines.

The division plays a crucial role in ensuring that building By-laws align with national building codes and promote safe and sustainable construction practices.

These agencies and organizations are actively involved in implementing building By-laws and undertaking various activities to promote planned urban development. They collaborate with other stakeholders, conduct inspections, provide technical support, and raise awareness among the public and construction professionals about the importance of complying with building By-laws for creating safe, sustainable, and well-planned urban environments.

### **Urban Planning related policy, Acts, Strategies, guidelines, manuals**

Urban planning policies, acts, strategies, guidelines, and manuals are primarily implemented and regulated by the government authorities at various levels. Here are some key documents and institutions related to urban planning :

**Urban Planning Policy 2071:** This policy provides a framework for urban development and planning in Nepal. It emphasizes sustainable urbanization, land use planning, infrastructure development, and social inclusion.

**Local Government Operation Act, 2074:** This act empowers local governments to plan, regulate, and manage urban areas within their jurisdictions. It provides guidelines for urban governance, including urban planning and development.

**National Urban Development Strategy (NUDS):** NUDES serves as a roadmap for urban development in Nepal. It outlines the government's vision, objectives, and strategies to achieve sustainable urbanization and improve the quality of life in urban areas.

**Integrated Settlement Development Guidelines:** These guidelines provide a comprehensive framework for planning and developing integrated settlements in urban areas. It covers aspects such as land use planning, housing, infrastructure, environmental management, and social amenities.

**Kathmandu Valley Development Authority (KVDA):** KVDA is an autonomous government body responsible for planning, regulating, and managing urban development in the Kathmandu Valley. It formulates development plans, issues building permits, and oversees urban infrastructure projects.

**Municipal Acts and By-laws:** Each municipality in Nepal has its own acts and By-laws related to urban planning and development. These documents provide guidelines for land use, zoning, building permits, environmental protection, and other urban planning aspects.

**Environmental Impact Assessment (EIA) Guidelines:** EIA guidelines are used to assess the potential environmental and social impacts of development projects. They ensure that urban development projects are implemented in an environmentally sustainable manner.

**Nepal National Building Code (NNBC):** NNBC is a comprehensive set of codes and guidelines for building design, construction, and safety. It covers various aspects of building construction, including structural design, materials, plumbing, electrical systems, and fire safety.

## 1.1.6 Concept of Building By-laws

### 1. Basic Concept:

- 1) By-laws are rules conforming to technical norms and standards set by the Government of Nepal and enforced by the local government. By-laws are technical-legal instruments to regulate urban space and developments over it. This is not a town plan but a tool or means to implement it. By-laws must be consistent with the national policies, standards and also must be embedded to local conditions and aspirations.
- 2) Bye-law is also a social document. Social values and preferences influence norms and standards of By-laws in a significantly. Its implementation depends largely on participation of citizens.
- 3) Furthermore, it is also a political document as without the political determination, local authorities neither adopt the By-laws nor implement them.

### 2. Necessity of By-laws

- 1) These are enforced primarily to ensure public health (protection from environmental nuisances), public safety (protection from natural and anthropogenic hazards), and public

welfare (unhindered access to and enjoyment of sun-light, air-circulation; protection of and access to public space and natural resources).

- 2) By-laws, which may combine both planning and building By-laws, regulate space and the constructions built over it. Planning By-laws control space and locations of development. It delineates and regulates (a) land use, (b) public open space, (c) Right of Way (ROW), and (d) building setbacks. In comparison, building By-laws control the intensity of development by regulating (a) building density, (b) building bulk (that is length, breadth and height), and (c) building architecture.
- 3) Several factors influence the standards of By-laws. These include land availability—which puts pressure for increased development density in case of land scarcity; community values—especially in regard to preservation of natural resources and heritages; capacity of infrastructure provisions such as road, drainage, sewer and water supply; availability of local building materials and existing building technology; and income.

### **3. History of By-laws in Nepal**

- 1) In Nepal, the advent of (plan-guided) by-law may be traced to the aftermath of the preparing of comprehensive physical development plan of the Kathmandu Valley in the late 1960s and establishing the Kathmandu Valley Plan Implementation Committee in 1972. By-Law of the Valley of 1976 is the first comprehensive By-laws enforced in the country. This By-law has continued to evolve since then.
- 2) The last major revision in by-law was carried out in 1990; some minor changes have been occasionally made. Hence, By-laws of 1990 continue to prevail today. However, except in Kathmandu Valley, the status of By-laws enforcement in Nepal is limited. Most municipalities have not adopted and enforced By-laws.

### **4. Legislative provisions for By-laws**

- 1) Municipalities derive authority to prepare and enforce By-laws from the Local Governance Operation Act 2017. It has empowered municipalities to prepare and implement municipal plans, By-laws and issue building permits. On the other hand, Planning Authorities such as Town Development Committees (TDCs) and Kathmandu Valley Development Authority derive land use planning and development control authority from Town Development Act, 1988 and Kathmandu Valley Development Authority Act, 1988 respectively.
- 2) Building Act of 1998 allows the Ministry of Urban Development (MoUD) to coordinate and keep oversight on the implementing Building Codes by the local bodies. Nepal National Building Code (NBC) attempts to ensure the structural safety of the building against seismic conditions. The code ensures safety by maintaining among others structural design, architectural standards, and precautions against fire and site conditions.
- 3) Besides these, several sectoral laws remain instrumental in preparing of specific By-laws. Public Road Act 1974 (2031) categorizes roads and fixes Right of Way (ROW) and Building Setbacks. Ancient Monument Act 1956 (2013) delineates monument zones and sets

development conditions and provisions within monument zones. Environment Protection Act 2019 and Regulations 2020 requires developers to carry out Brief Environmental Study (BES), initial environment examination (IEE) and environmental impact assessment (EIA) by the developers.

## **5. Benefit and Impact of By-laws**

- 1) By-laws benefit in multiple ways. First, it helps to ensure safer settlements by avoiding developments to risk sensitive areas. Second, it helps to conserve natural resources including agricultural land by discouraging or containing development from proliferating to such sites. Third, it helps to conserve cultural heritages vis-à-vis improve urban built environment, as By-laws control location, intensity (density), nature and pace of development in concurrence with The place's carrying capacity and infrastructure provisions. All these in tandem contribute to sustainable urbanization and economic development.
- 2) However, By-laws also tend to have impacts. Enforcement of By-laws, especially which is growth restriction may constrain land supply. Consequently, this may have implications for increasing land value. This may affect new land buyers and even phase out economically weaker section from the urban land market. By-laws may also become exclusionary in that they may exclude economically weaker or ethnic groups by influencing development density and land sub-division control.
- 3) Building a house is everyone's dream. To start construction & get approval of drawings from concerned authorities it is necessary to ensure that house design follows the municipality Building By-laws. These laws are rules and regulations drawn up by the government of every country, to assure a systematic and disciplined town growth.
- 4) Without these laws, people will tend to construct buildings without any set of standards for example, the height of building, the number of floors which allowed for construction or even GCR, leading to haphazard urbanization. Following these laws will also ensure the maximum utilization of available space and safety of the people living in and around the house & even adds value to open space one must have.
- 5) It is to be noted that building By-laws are unique to every region. What may be applicable in a village may not be practical or possible in the city.

## **6. National and International Comparison**

- 1) The authorities impose some form of control on land use and building construction is imposed in all cities. Zoning is a comprehensive statutory planning tool that regulates both space and building construction over it. Zoning through the delineation of different land use zones excludes incompatible land use. Through density thresholds, it regulates the intensity of development. And through building bulk provisions, it regulates the buildings' height, size, and shape. Local bodies are the main authorities for enforcing zoning.

## 1.2 Basic Building By-laws

### 1.2.1 Compound Wall

#### 1. *Brief Concept:*

The compound wall serves as a boundary or perimeter wall around a property and plays a crucial role in providing security, privacy, and defining property limits. Here is a brief concept about the Basic Building By-laws related to compound walls:

**Height and dimensions:** The By-laws define the permissible height and dimensions for compound walls based on the zoning regulations of the area. The height may vary depending on the location, type of property, and purpose of the wall.

**Materials:** Common materials include bricks, concrete blocks, stone, or a combination of these materials. The choice of materials should ensure durability, strength, and compatibility with the surrounding environment.

**Structural stability:** Compound walls must be designed and constructed to withstand the forces they may be subjected to, such as wind loads, seismic activity, and soil conditions.

**Setbacks:** Compound walls should be constructed maintaining set back from public roads. Setbacks ensure proper access, visibility, and maintenance of the wall.

**Aesthetics and finishes:** This include considerations such as the use of appropriate colors, textures, and architectural elements that harmonize with the surroundings.

**Permissions and approvals:** Prior to constructing a compound wall, it is generally required to obtain necessary permits and approvals from the local authority or municipality.

## 2. Basic By-laws

S.No	Basic Rules
1.1	There must be permission from the chief administrative officer of the local government for the construction of compound wall
1.2	The maximum height of the compound wall shall not exceed 1.2 meter. The Chief Administration can permit keeping wire mesh not exceeding 0.6-meter height above 1.2 meter. <i>[Structure: 1.2 meter; Wire Mesh: 0.6 meters, Total height of compound wall: 1.8 meters]</i>
1.3	If the house owner has a requirement to increase the height of the wire mesh to more than 0.6 meters, they shall submit the structural design of the compound wall prepared by the certified engineer.
1.4	Security agencies of the government and diplomatic agencies of foreign government can be permitted construct compound wall with height of more 1.2 meter if deemed necessary .
1.5	The meeting of the local assembly has the right to ban the construction of compound walls in any area under their geographic boundary for beautification of the local level.
1.6	The meeting of the local assembly can decide to enforce colour codes, structural codes and compound wall design for beautification and uniformity.
1.7	Compound walls cannot be constructed within the boundary of rights of way of all types of roads: local , provincial and national.

## 3. Basic Designs

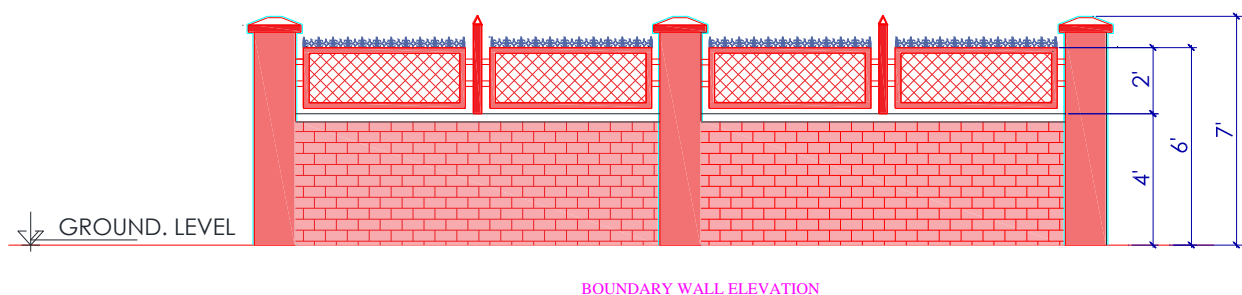

Source: Basic Standards on Settlement Development, Urban Planning and Building, 2015

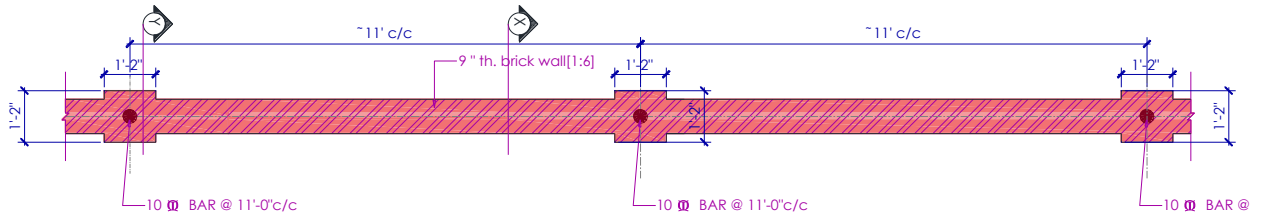

TYPICAL BOUNDARY WALL PLAN

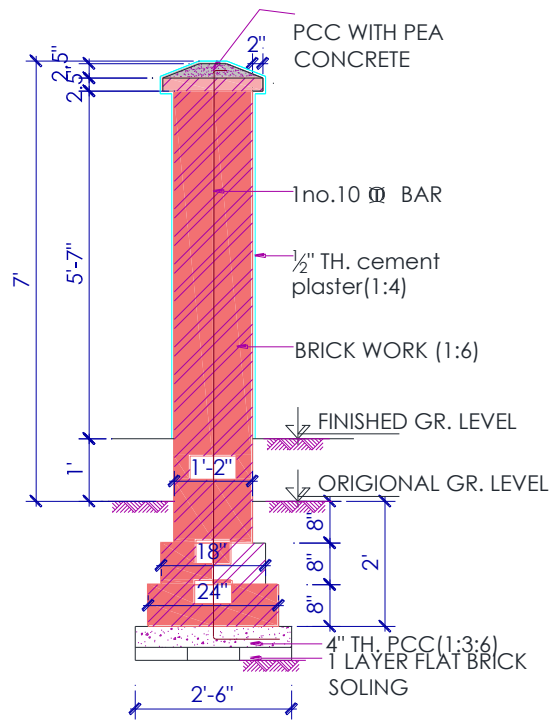

BOUNDARY WALL SECTION:-Y.Y



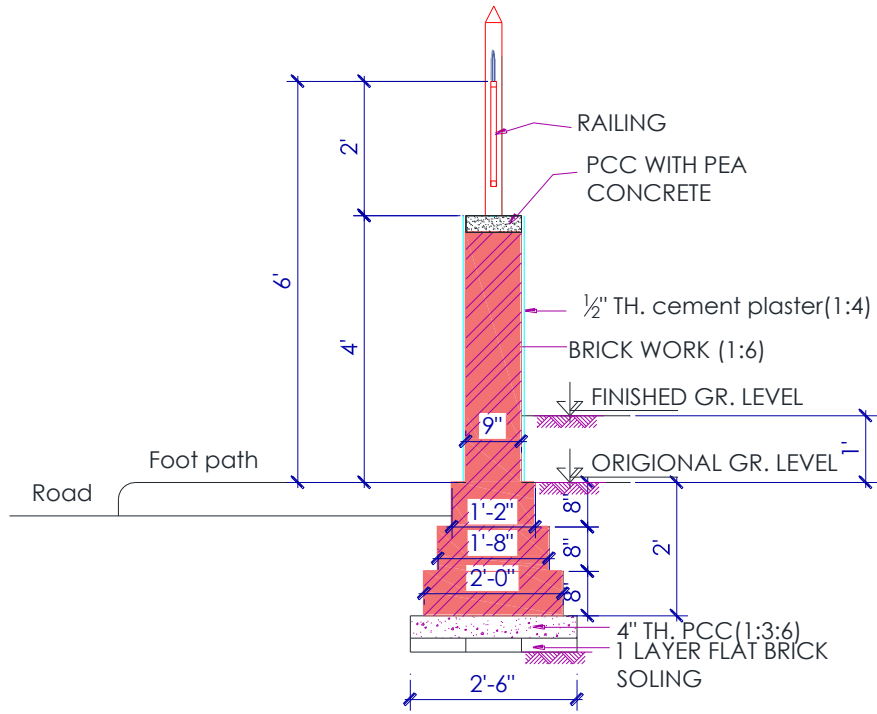

**BOUNDARY WALL SECTION:-X.X**

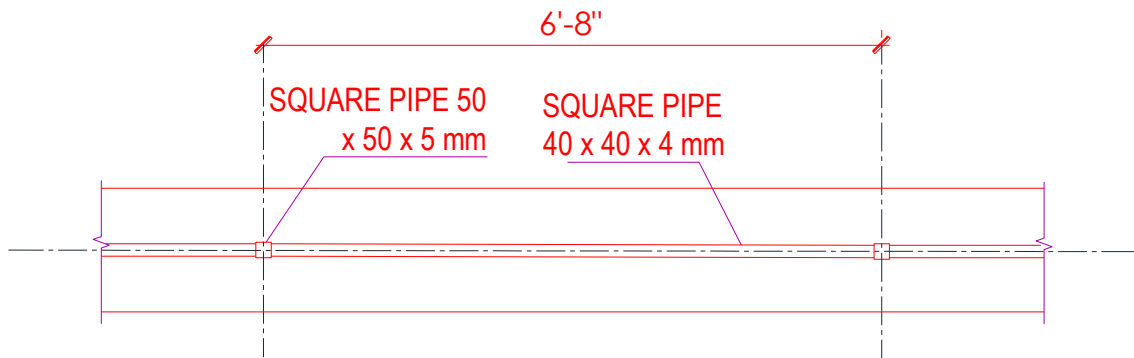

**Plan of GI Wire Mesh Fencing over Stone Wall**

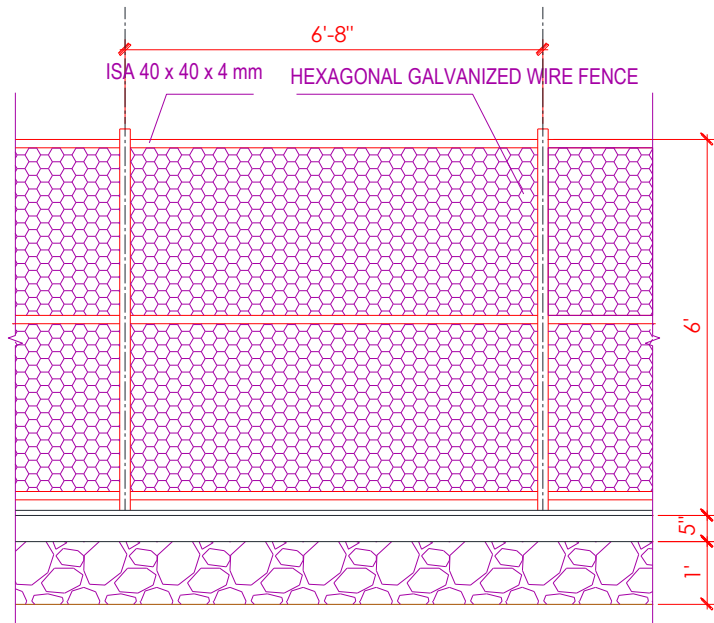

Elevation of GI Wire Mesh Fencing over Stone Wall

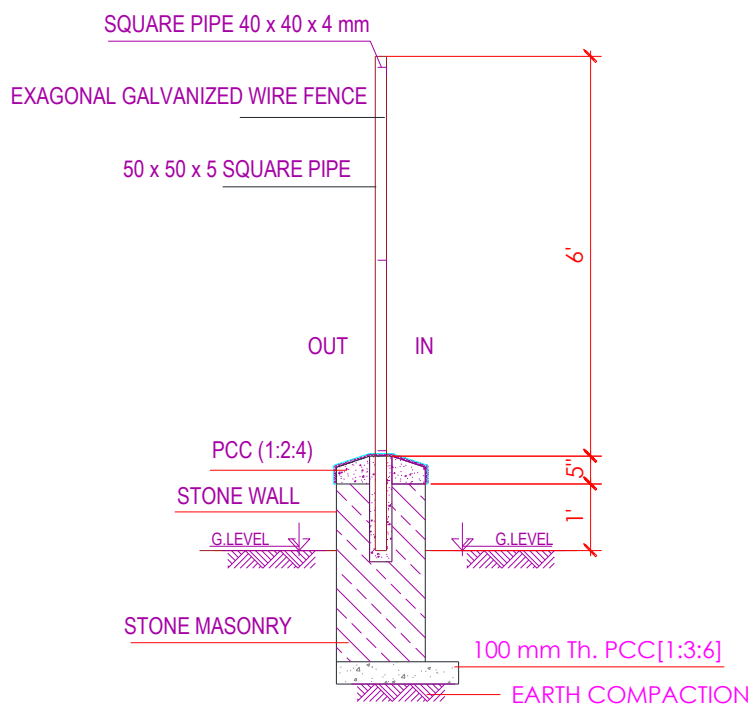

Section of GI Wire Mesh Fencing over Stone Wall

4. *Some Useful design*

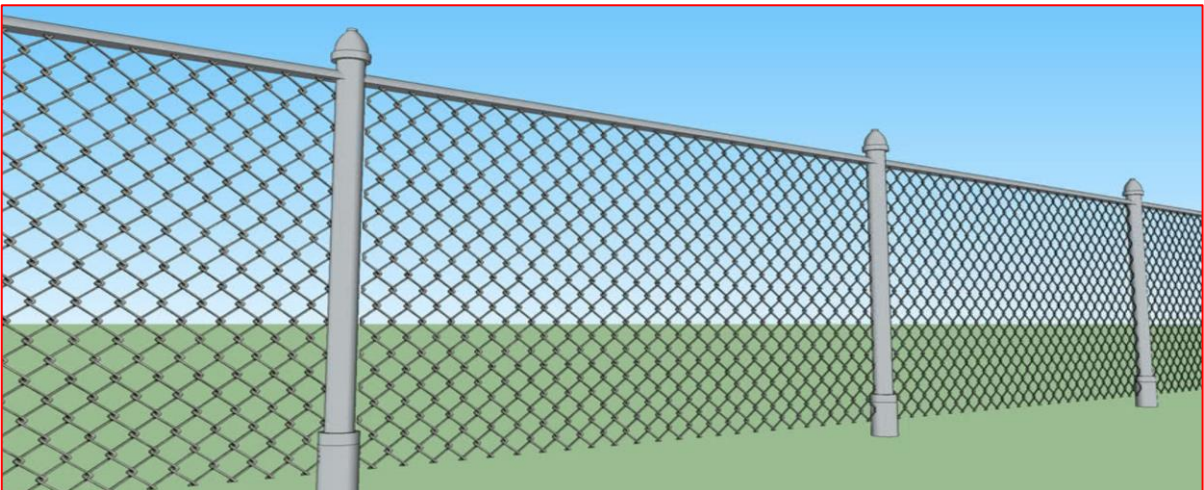



*Source: Internet*



*Source: Internet*

## 1.2.2 Rights of Way

### 1. *Brief Concept:*

The concept of "Right of Way" (ROW) refers to the legal right of individuals or entities to access and pass through a specific pathway or corridor that is designated for public or private use. The Right of Way is an important aspect of land and property ownership and is governed by various laws and regulations. Here is a brief concept of the Right of Way:

**Definition and purpose:** The Right of Way is a legal easement that grants certain rights to individuals or entities to pass through a particular piece of land or property owned by another party. It is established to ensure the smooth movement and accessibility of people, vehicles, utilities, or infrastructure across different properties.

**Types of Right of Way:** In Nepal, there are different types of Right of Way, including public, private, and utility easements:

**Public Right of Way:** These are pathways, roads, or streets that are dedicated for public use and managed by the government or local authorities. They provide access to the general public and allow for the movement of vehicles, pedestrians, and utilities.

**Private Right of Way:** These are easements granted by the property owner for specific individuals or entities to access their property. Private Right of Way can be established through legal agreements, servitudes, or recorded deeds.

**Utility Right of Way:** Utility companies, such as electricity, water, or telecommunication providers, may have the right to access certain areas of private properties to install, operate, and maintain their infrastructure. These easements are typically granted through agreements or regulations.

**Establishment and regulation:** The establishment and regulation of Right of Way are governed by various laws and regulations at the national, provincial, and local levels. The Land Act, Land Registration Act, and other relevant legislation provide guidelines for the creation, transfer, and maintenance of Right of Way.

**Acquisition and compensation:** In certain cases, the government or authorities may acquire land or properties for public infrastructure projects or urban development, which may involve the acquisition of Right of Way. In such instances, the affected property owners are entitled to fair compensation as per the prevailing laws and regulations.

## 2. Basic By-laws

S.No	Basic Rules
2.1	No construction other than road shall be constructed inside the boundary of rights of way
2.2	The rights of way of the road constructed from 8 April 2016 shall be at least 6 meters (3 meters right and 3 meters left from the centre). However, with the recommendation of a technical committee formed by the local executive, the local assembly can decide to keep this limit 4 meter on technical ground in hilly and mountainous areas.
2.3	The rights of way cannot be reduced once it is decided
2.4	The rights of way of road constructed before 8 <sup>th</sup> April 2015 with less than 4-meter width shall be automatically increased by 4 meters for building permission and construction purposes. The Local government shall compensate the land owner for constructing the road if some of the lands inside the rights of way are private.
2.5	It is the duty of local government to protect the rights of way.

## 3. Table of Right of Way

Category of road	Right of Way (Meter)	Setback	Sum of Right of Way & Setback	Responsible Organization
Arterial roads (Path)	50 Meter	6 meter	62 meter	Department of Road
Sub-arterials roads (Sadak)	30 Meter	6 meter	42 meter	Department of Road
Collector roads (Marg)	20 Meter	6 meter	32 meter	Provincial Government/ District Coordination Committee
Local roads (Upa-Marg)	12 Meter	1.5 meter	15 meter	Municipality/Rural Municipality

Source: Nepal Urban Road Standards, 2076

### 1.2.3 Floor Area Ratio

#### 1. *Brief Concept:*

Floor Area Ratio (FAR) is the ratio of the total covered area of a building to the size of the plot on which it is built. It is a measure of how much floor space can be built on a given plot.

FAR is regulated by the Building Byelaws of various municipalities. The FAR varies depending on the type of building and the location of the plot. For example, the FAR for residential buildings in Kathmandu Metropolitan City is 2.5, while the FAR for commercial buildings is 3.5.

The FAR is an important consideration for both developers and homeowners. Developers need to ensure that their buildings comply with the FAR in order to obtain building permits. Homeowners need to be aware of the FAR in order to understand the maximum amount of floor space that can be built on their property.

#### 2. *Basic By-laws*

S.No	Basic Rules
3.1	It is formulated as the ratio of all the floors' total covered area (actual area) of to the plot area. The following formula is used to calculate the floor area ratio $\text{FAR} = \frac{\text{Total area of all floors}}{\text{Plot Area}}$
3.2	Local assembly can decide to determine the maximum ceiling of floor area ratio on the recommendation of technical committees formed by the local executive.
3.3	The height of the building shall be determined by the floor area ration in the consistency of the light plane
3.4	Local level has to follow the provisions of national byelaws, 2072 and national model building By-laws while deciding the maximum ceiling to floor area ratio.

#### 3. *Maximum Floor Area Ratio*

Building	Maximum FAR
Residential Building	1.75
School Hostel	2.00
Guest House Boarding and Lodge	1.5
Religious Guest House	1.5

Local Shop	1.5
Community Building	1.5
Ware House	1.5
Hotel	1.5
Government Building	2.0
Hospital	1.25
Nursing Home	2.0
School	1.25
University	1.25
Auditorium and Community Hall	1.00
Religious Centre	1.00
Police Station	1.25
<i>Source: Model Building By-laws, 2016: Ministry of Urban Development</i>	

#### 4. Examples

- 1) Suppose Person X has got a plot of 1,000 square feet and the permissible FAR, according to the municipality is 2.5. He can construct a building maximum build up area of 2500 square feet obeying all other basic By-laws.
- 2) The FAR for every building will differ depending upon its usage, type of construction, locality the width of the road
- 3) The floor area of a building includes the area of all the floors, including the basement, ground floor, and upper floors. It does not include the area of balconies, terraces, and staircases.



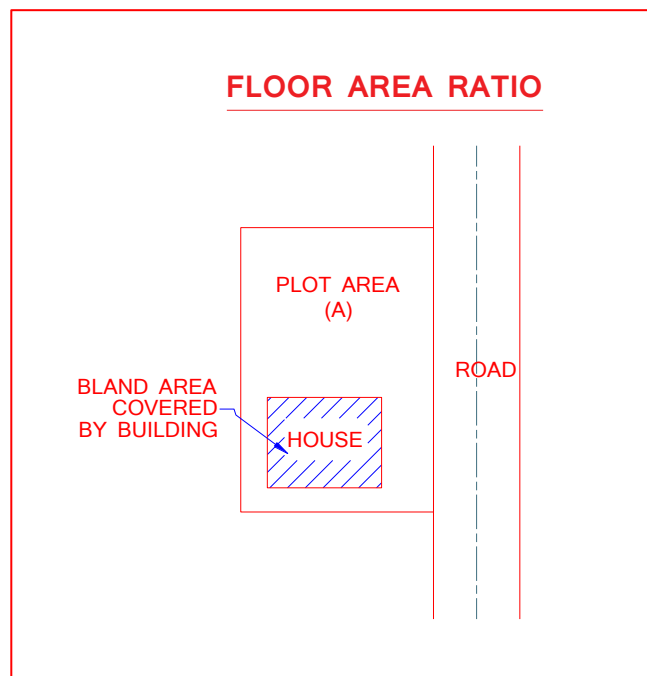
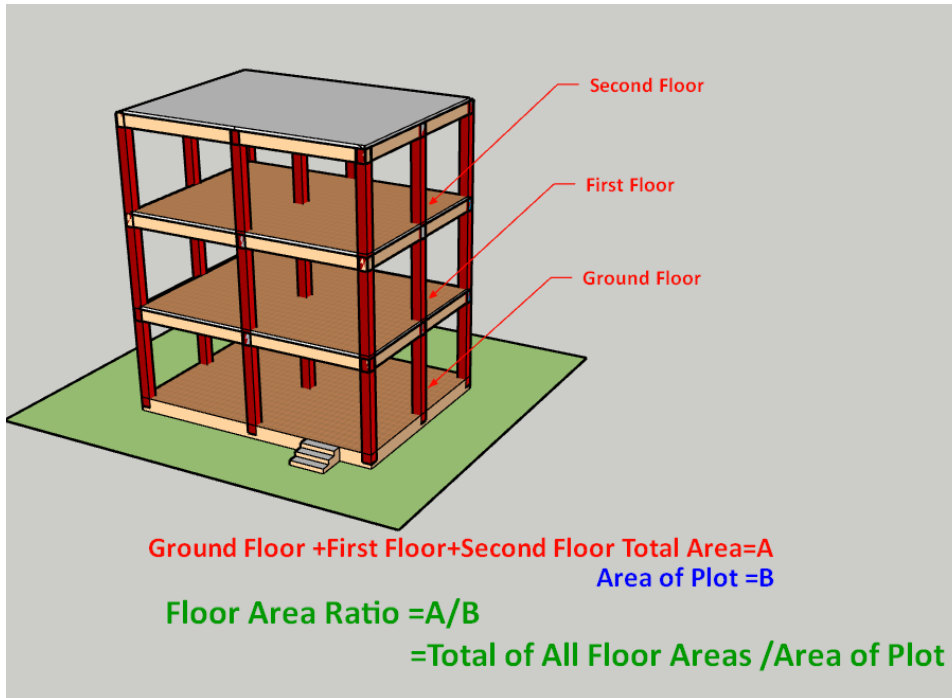

## 1.2.4 Ground Coverage Ratio

### 1. Basic By-laws

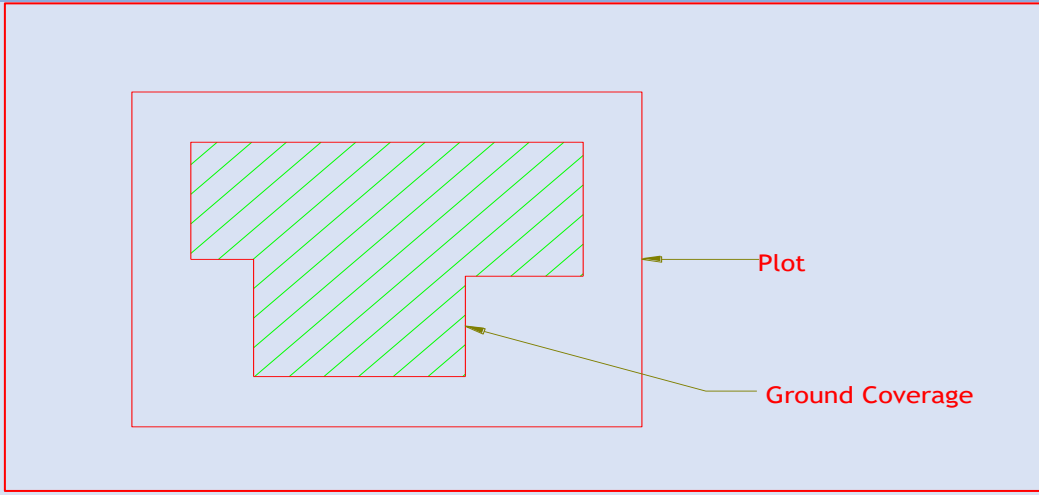
S.No	Basic Rules
4.1	The total area covered by the building on the ground floor is known as ground coverage. Based on restrictions of height and FAR, the ground coverage can be adjusted to get maximum usage of the plot.
4.2	The ground coverage area is calculated by dividing the Building's Ground Floor area by the total plot area. Building area means the floor space of a building when looking down at it from the top $\text{Ground Coverage Area} = (\text{Building Ground Floor Area} / \text{Site Area}) \times 100$
4.3	
4.4	Maximum ground coverage for residential and mixed residential buildings shall not exceed 70 percent for land upto 250 square meter size and 60 percent for bigger than 250 square meter size.
4.5	The maximum ground coverage for buildings other than residential and mixed residential shall not exceed 50 percent of the total land. These include all corporate, public and institutional, and governmental buildings.
4.6	Any construction for exit the water and sewage outside the main building, such as a culvert, drainage, catch pit, gutter are not counted for the ground coverage.
4.7	The construction of a compound wall will not be counted for ground coverage .

## 2. Maximum Ground Coverage

Building	Maximum Ground Coverage( %)
Residential Building	70
School Hostel	50
Guest House Boarding and Lodge	40
Religious Guest House	40
Local Shop	60
Community Building	40
Warehouse	40
Hotel	40
Government Building	50
Hospital	35
Nursing Home	35
School	40
University	30
Auditorium and Community Hall	35
Religious Centre	40
Police Station	50

*Source: Model Building By-laws, 2016: Ministry of Urban Development*

## 1.2.5 Setback

### 1. *Basic Byelaws*

S.No	Basic Rules
5.1	A building setback is the open space between the building and the property boundary or lot line. We can construct the house only up to the setback line. This again varies for different types of buildings. The setback line is applicable not just in the front, but also around the entire building. The total plot area is another determining factor for the setback line.
5.2	The minimum width of the setback residential building shall be at least 1.5 meters from the neighbour's boundary for placing door and window openings. However, such a side setback is not mandatory for blank wall.
5.3	The minimum setback width for commercial cum residential buildings shall be at least 2 meters from the neighbour's boundary.
5.4	The minimum setback width for institutional, public and government buildings shall be at least 3 meters from the neighbour's boundary.
5.5	On the roadside, the minimum width of setback for residential buildings shall be at least 1.5 meters from the boundary of rights way of local road
5.6	On the roadside, the minimum width of setback for residential cum commercial building shall be at least 2 meters from the boundary of rights way of local road
5.7	On the roadside, the minimum width of setback for institutional, public and government building shall be at least 3 meter from the boundary of rights way of local road
5.8	On the roadside of national highways, the minimum width of setback for any building shall be at least 6 meters from the boundary of rights way.
5.9	No permanent construction such as boundary wall, ramp, steps etc. shall be permitted in the setback areas.
5.10	The height of the building will determine additional setback. There must be at least 2 meters of setback even for residential building in all side if the height of the building is more than 10 meters up to 17 meters.

## 2. *Setbacks*

Roadside Setback		
Description	Minimum Setback	Responsible Agencies
National highways	6 meter	Department of Road
Feeder Road	6 meter	Department of Road
District Road	6 meter	The Provinces
Local Road (Residential Building)	1.5 meter	Local Level
Local Road (Commercial cum Residential)	2 meters	Local Government
If the setback is not determined in the market areas of highways, feeder roads, and district roads.	3 meter	Department of Road and the Provinces
Setback on neighbour's side		
Description	Minimum Setback	Remarks
Residential buildings up to 10 meters height	1.5 meter	
Residential building more than 10 meter up to 17 meter height	3 meter	-
Residential cum commercial building more than 10 meters up to 17 meters in height	2 meter	
Building more than 17-meter height	5 meter	The ratio of height and neighbour setback shall be 4:1

### 3. Drawings for Setback

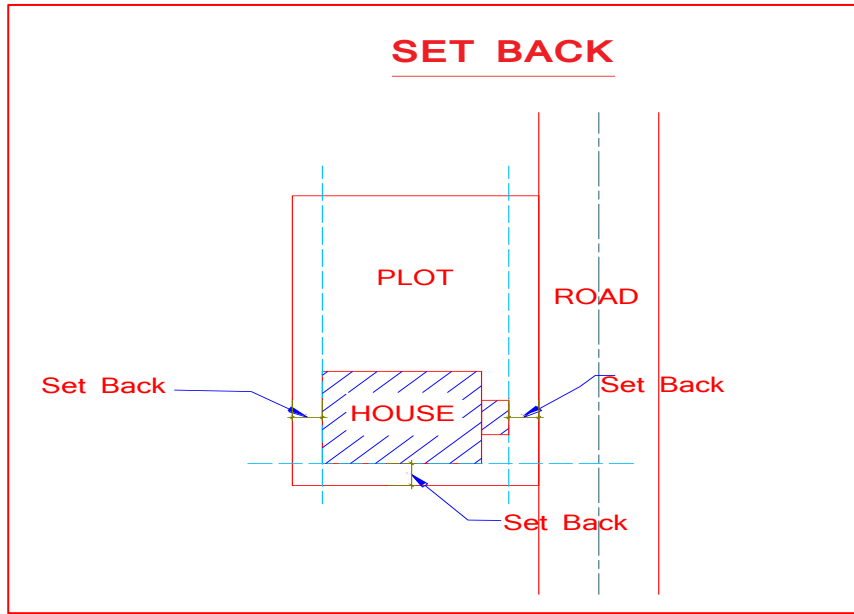

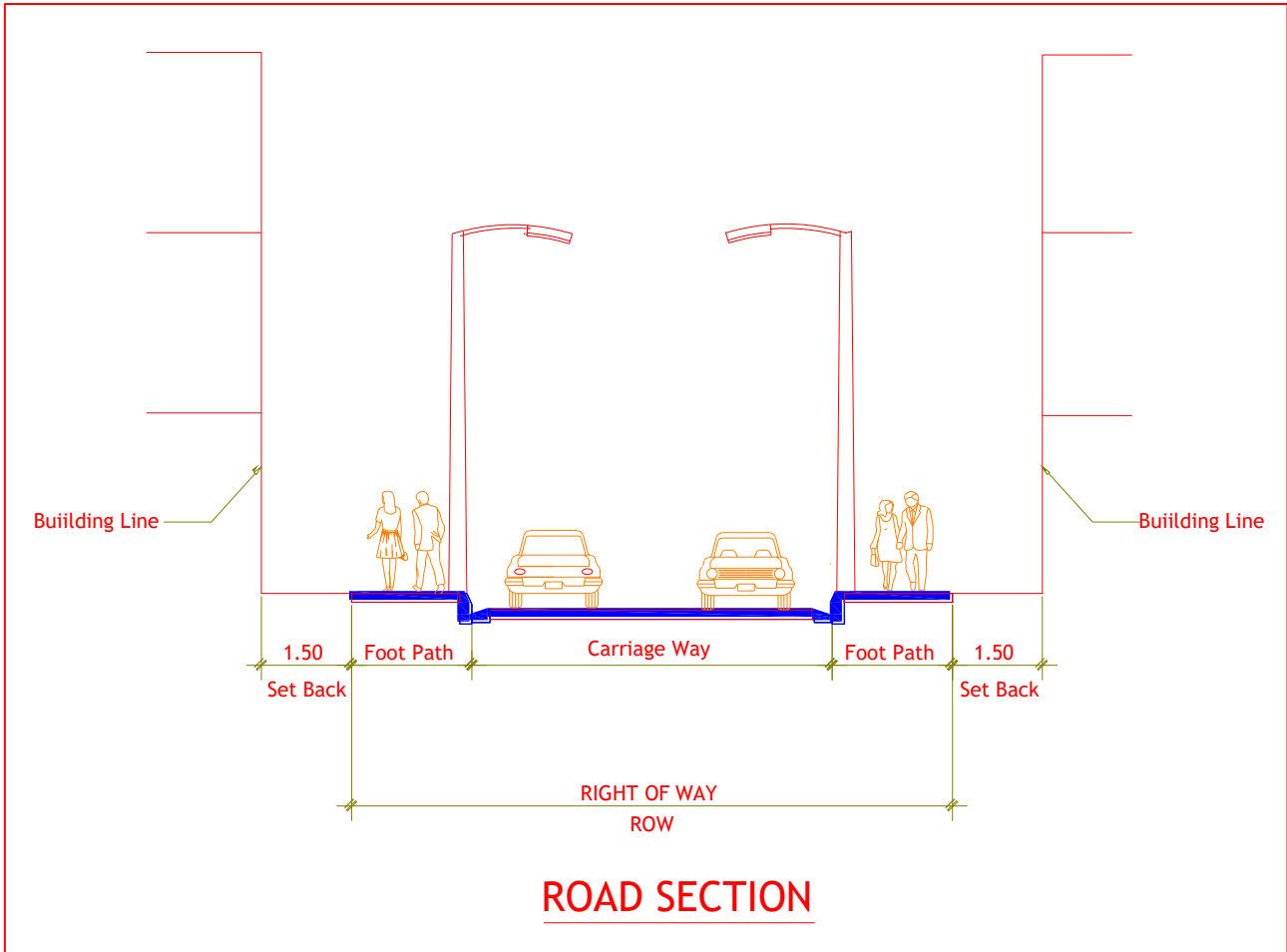
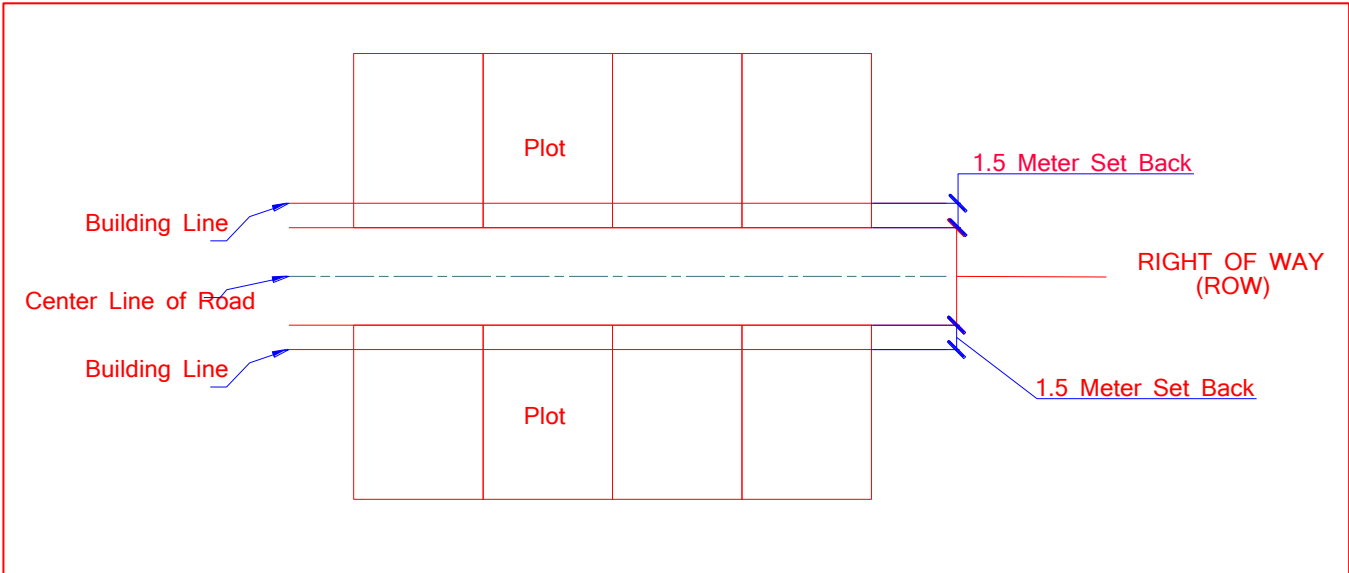

## 1.2.6 Height of the Building

### 1. Brief concept

The height of a building is the vertical distance from the average level of the ground around to the terrace of the upper most floor in case of a flat roofed building, to the center of the highest sloped part in case of buildings with the slope greater than 30° and to the eaves level of the highest sloped part in case of building with slope less than 30°.

The height of a building is regulated by the Building Byelaws of municipalities. The height varies depending on the type of building and the location of the plot. For example, the maximum height for residential buildings in Kathmandu Metropolitan City is 17 meters, while the maximum height for commercial buildings is 25 meters.

There are a number of factors that are considered when determining the height of a building, including:

- The seismic risk of the area
- The fire safety requirements
- The visual impact of the building on the surrounding area
- The availability of sunlight and ventilation
- The height of a building is an important consideration for both developers and homeowners.

Developers need to ensure that their buildings comply with the height restrictions in order to obtain building permits. Homeowners need to be aware of the height restrictions in order to understand the maximum height that can be built on their property.

### 2. Basic By-laws

S.No	Basic Rules
6.1	1. The height of the building shall be determined by the light plane, floor area ratio and height restriction
6.2	2. Local assembly can set the maximum limit of the height in accordance with the provision of a light plane
6.3	3. The height of a building is the vertical distance between the average level of the ground and the topmost point of the building. Remember, if there is a basement to the house, it will not be considered in height measurement.
6.4	4. Local government cannot permit constructing the building more than 17 meters tall. They must take permission from the Ministry of Urban Development to construct a building of more than 17-meter height.
6.5	5. In the heritage zone, the maximum height of the building shall not exceed 35 feet. The building shall not be taller than the main heritage building in the heritage zone



### 3. Basic Drawings

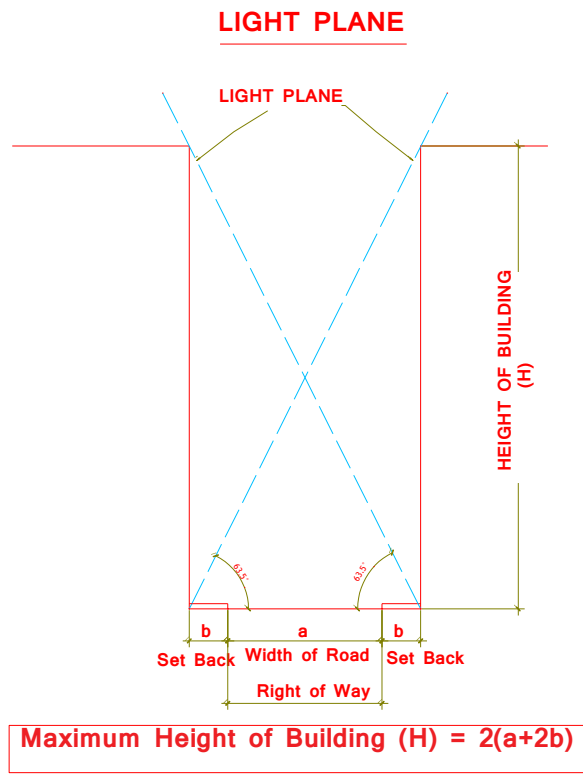

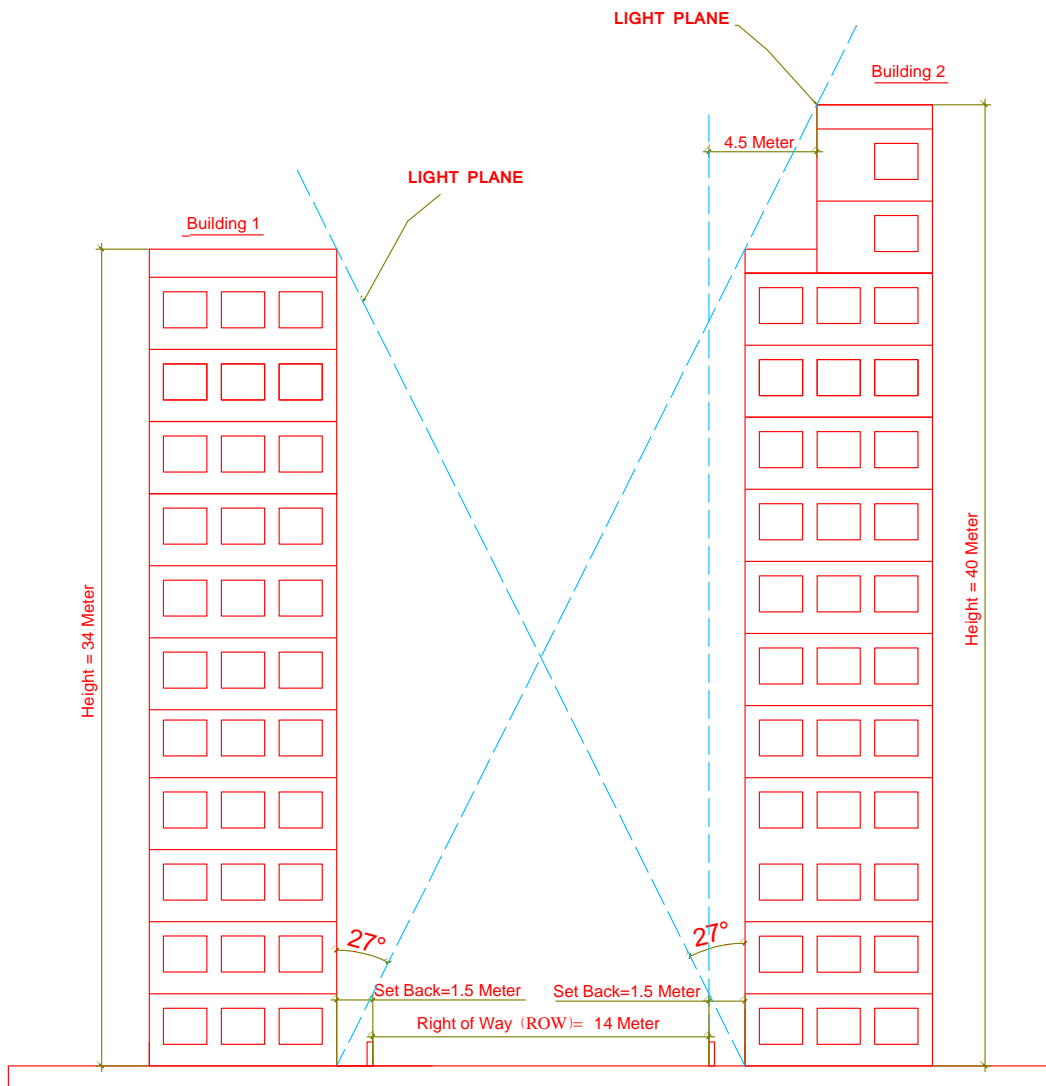

**Height of Building as per the Light Plane**

## 1.2.7 Septic Tank

### 1. Brief Concept

**Septic tank:** A septic tank is a large underground tank that treats wastewater from homes and businesses. The wastewater enters the tank and is separated into three layers: solids, scum, and effluent. The solids settle to the bottom of the tank and form sludge, while the scum floats to the top and forms grease. The effluent is the liquid that flows out of the tank and is either discharged into a soak pit or a leach field.

**Soak pit:** A soak pit is a small underground chamber that is used to absorb wastewater from septic tanks in Nepal. The wastewater flows into the soak pit and is slowly absorbed into the surrounding soil. Soak pits are typically made of concrete or bricks, and they should be located in areas with good drainage.

Both septic tanks and soak pits are important components of wastewater treatment systems. They help to remove harmful pollutants from wastewater and prevent them from contaminating groundwater.

Here are some of the benefits of using septic tanks and soak pits in Nepal:

- They are a relatively inexpensive way to treat wastewater.
- They are relatively easy to maintain.
- They are a sustainable way to treat wastewater.
- However, there are also some drawbacks to using septic tanks and soak pits in Nepal:
- They can be a nuisance if they are not properly maintained.
- They can be a potential source of groundwater contamination if they are not properly designed or installed.

Overall, septic tanks and soak pits are a reliable and effective way to treat wastewater. However, it is important to choose the right system for your needs and to have it properly designed and installed.

### 2. Basic Byelaws

S.No	Basic Rules
7.1	The construction of septic tank is an integral part of building construction. Local Government shall not provide building permission without the construction of septic tank.
7.2	No building completion report shall be issued without constructing the septic tank
7.3	The set back of septic tank from the boundary of neighbours shall be determined by local assembly.
7.4	Septic tank should not be attached to the neighbour land without permission of neighbour.
7.5	At least 1 meter shall be left form the boundary of neighbour for constructing septic tank. Local assembly can set the limit above this threshold.

### 3. Basic Design

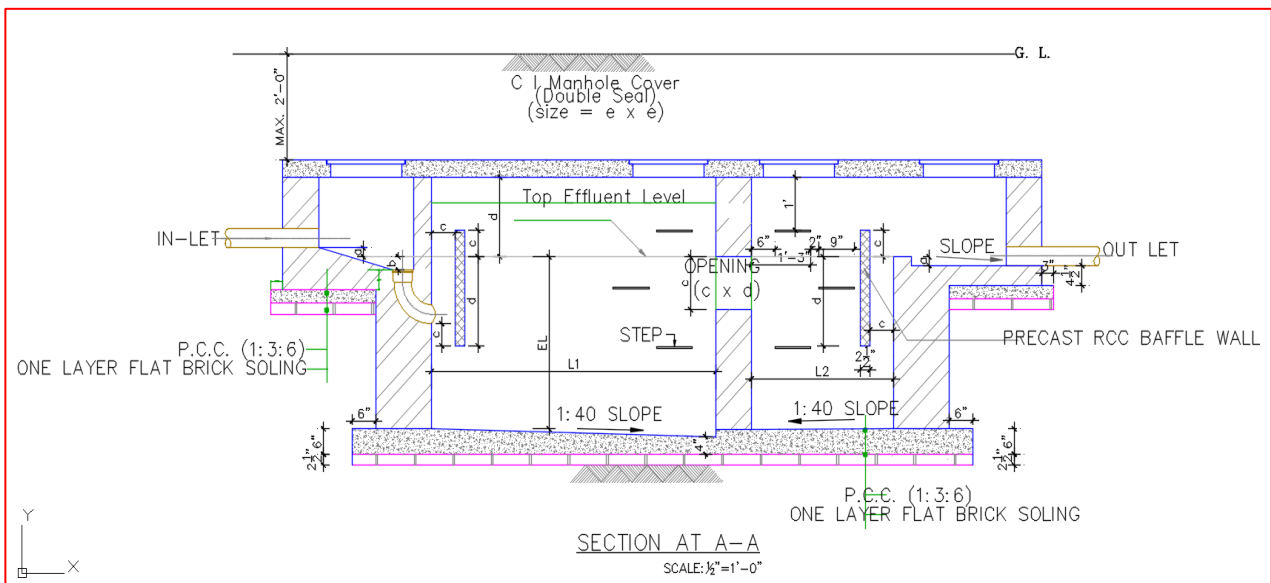
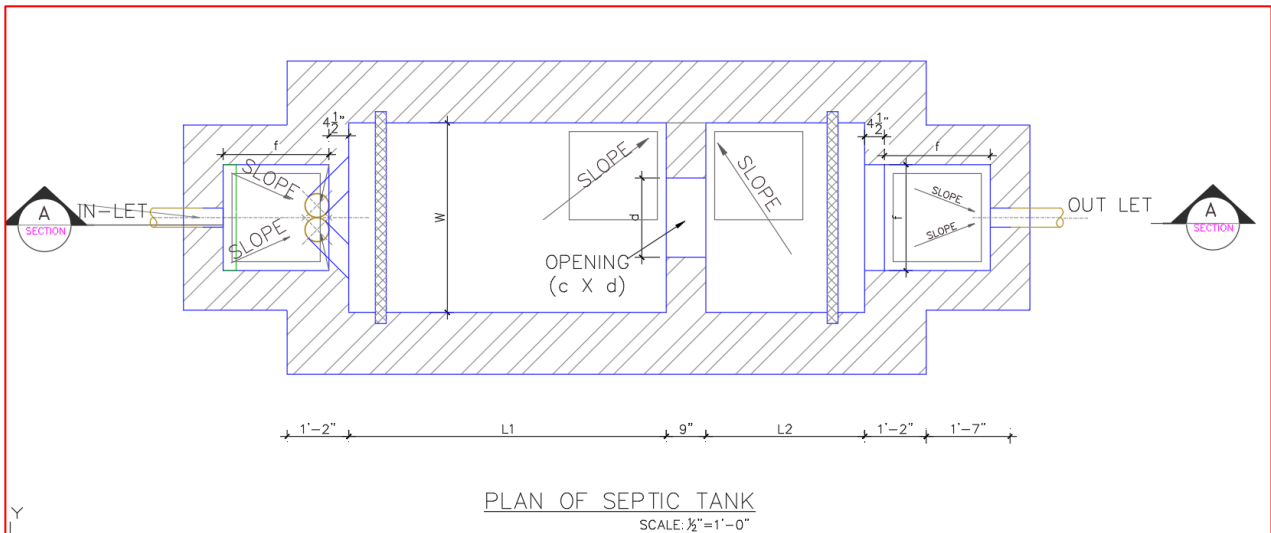

### SCHEDULE OF SEPTIC TANK

No of Users	Septic Tank No.	L1	L2	W	EL	No. & Type of Soak Pit
Up to 5	ST - 1	4'-0" (1.2 m.)	3'-0" (0.9 m.)	3'-0" (0.9 m.)	3'-0" (0.9 m.)	1 X S P - 1
Up to 10	ST - 2	5'-0" (1.5 m.)	3'-0" (0.9 m.)	3'-3" (1 m.)	3'-3" (1 m.)	1 X S P - 2

Up to 15	S T - 3	6'-0" (1.8 m.)	3'-0" (0.9 m.)	4'-0" (1.2 m.)	3'-3" (1 m.)	1 X S P - 3
Up to 20	S T - 4	7'-0" (2.1 m.)	3'-6" (1.05 m.)	4'-6" (1.4 m.)	3'-3" (1 m.)	1 X S P - 4
Up to 30	S T - 5	8'-0" (2.4 m.)	4'-0" (1.2 m.)	4'-6" (1.4 m.)	4'-0" (1.2 m.)	1 X S P - 5
Up to 50	S T - 6	8'-9" (2.7 m.)	4'-3" (1.3 m.)	6'-0" (1.8 m.)	5'-0" (1.5 m.)	1 X S P - 6
Up to 100	S T - 7	13'-0" (4.0 m.)	6'-6" (2.0 m.)	6'-6" (2.0 m.)	6'-0" (1.8 m.)	2 X S P - 6
Up to 150	S T - 8	15'-0" (4.6 m.)	7'-6" (2.3 m.)	8'-3" (2.5 m.)	6'-0" (1.8 m.)	3 X S P - 6
Up to 200	S T - 9	19'-9" (6.0 m.)	9'-9" (3.0 m.)	9'-0" (2.75 m.)	6'-0" (1.8 m.)	4 X S P - 6
Up to 300	S T - 10	23'-0" (7.0 m.)	11'-6" (3.5m.)	9'-9" (3.0 m.)	6'-6" (2.0 m.)	6 X S P - 6

Source: Department of Water Supply and Sanitation, Government of Nepal

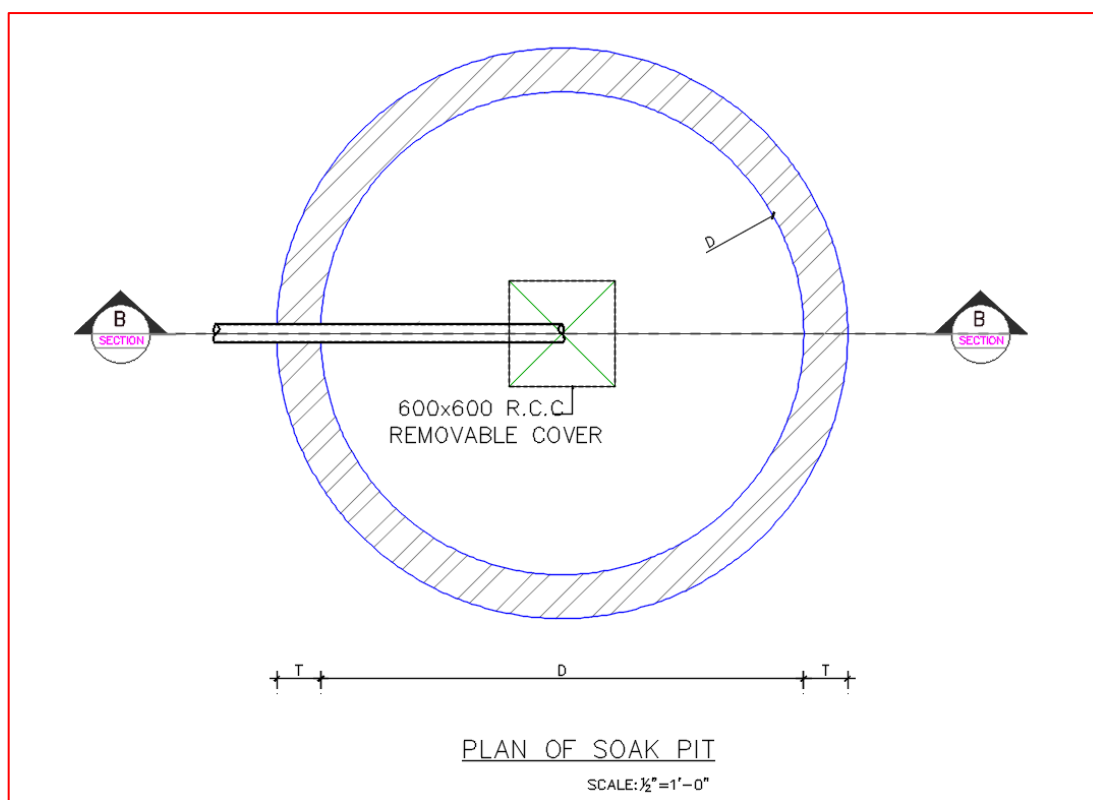

Source:

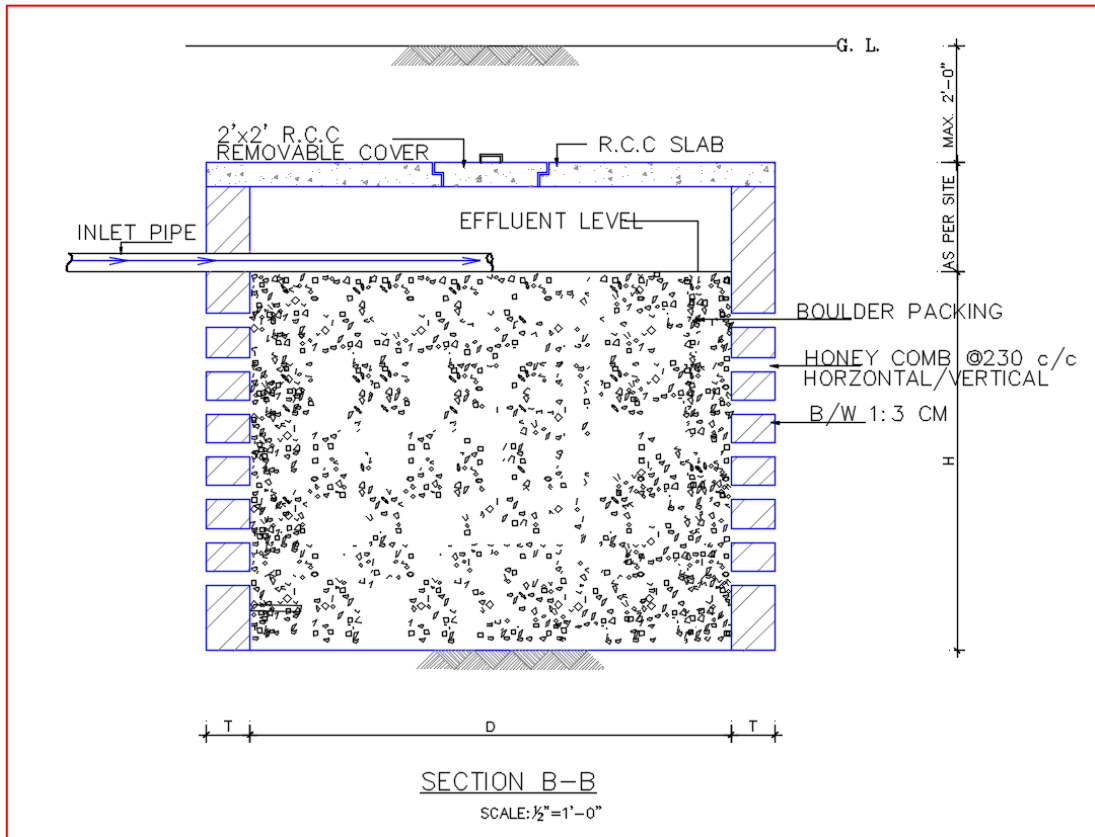

Department of Water Supply and Sanitation, Government of Nepal

### SCHEDULE OF SOAK PIT

Soak Pit Nos.	Diameter	Depth	Wall Thickness
S P - 1	5'-0" (1.5 m.)	6'-6" (2.0 m.)	9"
S P - 2	6'-6" (2.0 m.)	6'-6" (2.0 m.)	9"
S P - 3	8'-3" (2.5 m.)	6'-6" (2.0 m.)	9"
S P - 4	9'-9" (3.0 m.)	6'-6" (2.0 m.)	14"
S P - 5	13'-0" (4.0 m.)	6'-6" (2.0 m.)	14"
S P - 6	16'-6" (5.0m.)	9'-0" (2.75 m.)	14"

### Dimension Details

a: 2" or 50 mm.
b: 3" or 75 mm.
c: 6" or 150 mm.
d: 1'-6" or 450 mm
e : 2'-0" or 600 mm.
f: 2'-6" or 750 mm.

## 1.2.8 Building Construction Near the River, Pond, and Well

### 1. *Brief Concept*

Building construction near rivers, ponds, and wells requires careful consideration due to the potential risks and environmental concerns associated with such locations. Several guidelines are in practice to ensure the safety of structures and minimize the negative impact on the surrounding ecosystem.

**Environmental Impact Assessment (EIA):** Before initiating any construction project near rivers, ponds, or wells, an EIA is conducted to evaluate the potential environmental consequences. This assessment includes the analysis of water flow, erosion risks, flood-prone areas, and the impact on aquatic life.

**Setback Distances:** Specific setback distances from the water bodies are defined to maintain the ecological balance and prevent encroachment into flood zones. These distances vary depending on the local regulations and the size of the water body.

**Structural Design:** Buildings constructed near water bodies should be designed to withstand potential flood events and erosion. Elevated foundations, flood-resistant materials, and appropriate drainage systems are incorporated into the building design to minimize the risk of damage.

**Waste Management:** Adequate provisions for waste management and sewage treatment are essential to prevent contamination of the water bodies. Proper septic systems, waste disposal facilities, and sewage treatment plants should be established to ensure the protection of nearby water sources.

**Riparian Zone Conservation:** Riparian zones, which are the areas along the banks of rivers and ponds, are vital for maintaining water quality and preserving the habitat for aquatic organisms.

Guidelines promote the conservation of these zones by prohibiting construction activities within a certain distance from the water bodies.

**Erosion Control Measures:** Construction near rivers and ponds should incorporate erosion control measures such as retaining walls, riprap, or vegetation to prevent soil erosion and maintain the stability of the land.

Separate guidelines and regulations are in place to address the unique challenges of building construction near water bodies. These guidelines aim to balance development needs with environmental protection, ensuring sustainable construction practices and minimizing the impact on water resources and ecosystems. It is important for developers and builders to adhere to these guidelines and obtain necessary permits and clearances before undertaking any construction projects near rivers, ponds, or wells.

## 2. *Basic Byelaws*

S.No	Basic Rules
8.1	Local government shall not provide building permission if the proposed building negatively affects the sources of water.
8.2	Local government shall not permit the construction of the building if there are ponds, well, water sprouts, or wetlands in the proposed plot.
8.3	The minimum setback shall be 30 meters from the boundary of the river, lake and pond
8.4	The minimum setback shall be 50 meters from the boundary of the lake
8.5	The local government must protect the setback of rivers, ponds, wells and wetlands. No permission shall be issued to construct the building inside the setback.
8.6	At least one meter shall be left from the boundary of the neighbour to construct well inside the plot
8.7	Local government shall pass laws to make stronger By-laws than national ones to protect the water sources. They, however, cannot make weaker By-laws.
8.8	The inner diameter of the well must be at least 1 meter

## 3. *Minimum Setback to be left constructing building*

Areas	Minimum Setback
From the boundary of a river	30 meter
From the boundary of a lake	50 meter
From the boundary of an irrigation canal	10 meter



From the boundary of a wetland	50 meters
From the boundary of a public well and traditional water tap	4 meter
From the boundary of a pond in a heritage site	5 meter
From the boundary of Bagmati, Bishnumati and Manahar River	20 meter
From the boundary of the Hanumante river	20 meter
From the boundary of the Tukuche River	4 meter

## 1.2.9 Plotting of Land and Planning Permit

### 1. *Brief Concept*

Plotting of land is the process of dividing a piece of land into smaller plots for the purpose of sale or development. The plotting process must be done in accordance with the local building By-laws and regulations.

Planning permit is a document issued by the local authorities that allows the owner of a piece of land to develop it according to a specific plan. The planning permit process typically includes an assessment of the land's suitability for development, as well as a review of the proposed development plan.

In Nepal, the plotting of land and planning permit are regulated by the Building By-laws of MOUD and the Building Byelaws of various municipalities. The specific requirements for plotting and planning permits vary depending on the municipality.

Here are some of the key requirements for plotting and planning permits:

The land must be located in an area that is zoned for residential or commercial development.

The land must have access to roads, water, and sanitation facilities.

The proposed development plan must be in accordance with the local building By-laws and regulations.

The planning permit application must be accompanied by a fee.

The plotting of land and planning permit process can be time-consuming and complex. However, it is important to follow the correct procedures in order to ensure that the development of the land is done in a safe and legal manner.

Here are some of the benefits of obtaining a planning permit:

It gives you the legal right to develop the land according to your plan.

It ensures that the development of the land is done in a safe and sustainable manner.

It can increase the value of the land.

If you are planning to develop a piece of land in Nepal, it is important to obtain a planning permit from the local authorities. This will ensure that the development of the land is done in a safe and legal manner, and it can also increase the value of the land.

Planning Procedures and Regulations in Nepal:

## 2. **Basic Byelaws**

S.No	Basic Rules
9.1	Nobody shall plot the land for housing or another purpose without getting planning permit from the local government
9.2	For plotting, one should submit a detailed planning permission to the local government prepared by certified engineers
9.3	At least 15% of the total land shall be allocated for road construction and additional 5 percent shall be allocated to open space in planning areas
9.4	No permission will be provided for plotting of land without having 8-meter access road to the planning site
9.5	Each plot should have access to 6-meter roads in the planning zone

## 3. **Size of plot of building**

Type of Building	Size of plot ( Minimum)
Hospital	300 square meter
Residential building	80 square meter
Joint Apartment	2250 square meter
Residential cum commercial building	80 square meter
Religious Gust House	800 square meter
Lodge	800 square meter
The Industrial plot in the industrial zone	200 square meter

## 1.2.10 Miscellaneous

### 1. *Basic Rule*

S.No	Basic Rules
10.1	Soil Test: It is mandatory for soil test for A (International State of Art of Building) and B (Professional Engineered Buildings) class buildings and for any building above 3 storey height, plinth area of more than 100 Square meters and structural span more than 4,5 meters.
10.2	For the construction of buildings above 17 meters in height, there must be designated areas allocated by the local government based on soil tests.
10.3	No permission will be provided to build houses in the areas prohibited by Department of Mines and Geology for geological safety purposes.
10.4	There must be an emergency response plan in the joint apartment and public building
10.5	The height of the plinth shall not encroach on the rights of way.

## 1.2.11 Planning By-laws and Land Use Zones

### 1. Brief Concept

Planning By-laws and land use zones play a vital role in regulating development activities and land use. Here's a brief concept explaining these terms:

#### **Planning By-laws:**

Planning By-laws, also known as development regulations or zoning regulations, are local government regulations that govern land use and development within a specific jurisdiction. These regulations provide guidelines and standards for the use of land, the size and setback requirements of buildings, infrastructure provisions, and other aspects of urban planning and development.

Planning By-laws are typically developed and enforced at the local level by municipalities or urban planning authorities. These By-laws are based on the provisions outlined in the country's relevant laws, such as the Local Government Operation Act and the Land Use Act.

The planning By-laws cover various aspects, including:

**Land Use Zoning:** They establish different zones within the jurisdiction, such as residential, commercial, industrial, recreational, or agricultural zones. Each zone has specific regulations that determine the permitted land uses, building densities, setbacks, and other development parameters.

**Building Height and Design:** By-laws specify the permissible height of buildings and provide guidelines for architectural design, building materials, and facade treatments. They aim to maintain the aesthetic character of the area and ensure compatibility with the surroundings.

**Infrastructure Requirements:** The By-laws may outline the standards for infrastructure provision, such as roads, water supply, drainage systems, and parking facilities. These requirements ensure that new developments have adequate infrastructure support and minimize the strain on existing services.

**Open Space and Environmental Considerations:** Planning By-laws may include provisions for open space requirements, green areas, and environmental safeguards. They promote the preservation of natural features, control soil erosion, and address issues related to waste management, air quality, and noise pollution.

#### **Land Use Zones:**

Land use zones are specific areas designated within a jurisdiction, each with its own permitted uses, regulations, and restrictions. These zones are typically established through the planning process and reflected in the planning By-laws.

The delineation of land use zones helps organize urban development, manage land resources efficiently, and create harmonious and sustainable environments within the jurisdiction. It guides the decision-making process for land development and ensures that different land uses are appropriately separated to maintain functional and livable communities.

It's important to note that specific regulations and zone designations may vary between different municipalities or urban planning authorities in Nepal. The local governments are responsible for

developing and implementing the planning By-laws and land use zones based on the unique characteristics and needs of their respective areas.

The local government is responsible for land use planning within their jurisdiction. They develop master plans and land use regulations to guide the development of different areas.

The Land Use Act provides the legal framework for land use planning and management at the local level.

The master plans outline the zoning regulations, land allocation for various purposes (residential, commercial, industrial, agricultural, etc.), and development control measures.

**Building Types and Structures:**

Nepal has regulations and guidelines for different types of buildings and structures, including residential, commercial, industrial, and public buildings.

### **Building Permits and Inspections:**

Local governments issue building permits after reviewing design plans and ensuring compliance with building codes and regulations.

During construction, inspections are conducted to verify that the construction adheres to the approved plans and meets the required standards.

The local government's building department or engineering division is responsible for conducting these inspections and ensuring compliance.

### **Land Use Monitoring:**

Local governments monitor land use to ensure compliance with the master plans and zoning regulations.

Regular monitoring helps identify any unauthorized land use or construction activities that violate the regulations.

Violations are addressed through enforcement actions, such as issuing warnings, fines, or demolition orders.

### **Post-Construction Monitoring:**

Post-construction monitoring ensures that buildings continue to meet safety and environmental standards after completion.

It involves periodic inspections to check the structural integrity, fire safety systems, electrical installations, and other aspects of the building.

Non-compliance with regulations may result in penalties or orders to rectify deficiencies.

It is important for local governments to have dedicated departments or agencies responsible for land use planning, building regulations, and monitoring. Effective enforcement and monitoring mechanisms ensure that land use and construction activities are in line with regulations, promoting safe and sustainable development in Nepal.

## 2. Introduction

- 1) For orderly development and to reduce conflicts between urban and environmental usage, land use regulations are exclusively dedicated to land use, building types and structures. The zoning of these categories is exposed in the Land Use Map. Two types of Land Use Zones are defined:
- 2) **-Non-Built-up Zones**, in principle, are reserved for, untouched nature; any usage is restricted as prescribed. Developments and structures are limited according to land use control for building or other purposes.
- 3) In **Built-up Zones**, usages, developments, and structures are permitted as prescribed. The land is only developed and used following the permitted use(s) prescribed for each Built-up Zone in the following sections.

## 3. Non Built-up Zones

- 1) **Forest Zones (F):** Forest Zones represent woodland, bush lands, and Zones without any vegetation.
- 2) **Agricultural Zones (A):** Agricultural Zones are designated only for agricultural purposes, cattle breeding, fishing, cash crops and horticulture.
- 3) **Green Spaces (G):** Green Spaces represent public and private parks, recreation Zones, botanical and zoological gardens, sports grounds, playgrounds, cemeteries, bathing areas and green open spaces
- 4) **Water Bodies (W):** Water Bodies represent lakes, ponds, streams, canals, rivers, flood areas and spaces to be kept free in the interest of flood control.
- 5) **Public Utility Use Spaces and Easements (U):** Public Utility Use Spaces and Easements are designated for waste and sewage disposal, for tipping and drains, water mains, sewers and cables.
- 6) **Conservation Zones (Cu):** Conservation Zones cover non-built-up Zones like water bodies and their banks, green spaces, forests and public utility use spaces which are necessary for conservation from the environmental point of view. No other activities except conservation, maintenance and recreation shall be allowed.

## 4. Built-up Zones

- 1) **Urban Expansion Zones**
  - The minimum required area of the plot for the construction of buildings in this Zone shall be 80 Square meter, and the minimum required frontage for the plot connected with the road shall be 6 Meters.
  - **Permitted Uses:**
    - Residential buildings

- Enterprises
- Retailing operations, bazaars, hotels, restaurants and businesses providing accommodation,
- Buildings for the self-employed such as physicians, dentists, lawyers, architects and engineers and for other independent contractors, who pursue their occupation similarly,
- Local administrative buildings and structures for religious, cultural, social, health-care and sports facilities,
- **Exceptional Permissible Uses:**
  - Filling stations,
  - Cinemas.
- Permission to construct buildings in this zone shall be granted if such construction satisfies the given norms.

## 2) Other Residential Zones (medium dense)

- Other residential zones are intended primarily to provide space for housing.
- Permitted Uses:
  - Residential buildings,
  - Shops, public houses, restaurants, small cottage industries, and non-disruptive commercial operations supply services to the Zone, but exclusively at ground level and fully contained within the original building
  - Buildings for the self-employed such as physicians, dentists, lawyers, architects and engineers and for other independent contractors, who pursue their occupation similarly,
  - Buildings and structures for educational, religious, cultural, social, health-care and sports facilities.
- **Exceptional Permissible Uses:**
  - Agricultural and horticultural production, trade and crafts on behalf of the livelihood of the residents,
  - Enterprises providing accommodation and other non-disruptive businesses,
  - Administrative buildings,
  - Filling stations.
- **Prohibited Uses:**
  - Large and medium-scale industries,
  - Storage of explosive materials,
  - Construction of oxidation ponds,
  - Mobile circus and circus,
  - Construction of headquarters of governmental or semi-governmental offices.

## 3) Dense Mixed Residential Zones (high dense)

- **Dense mixed residential zones** are intended to provide space for the housing and for accommodation of businesses that do not disrupt the residential function.
- **Permitted Uses:**
  - Residential buildings,
  - Business premises and office buildings,
  - Retailing operations, restaurants and businesses providing accommodation,
  - Shops, public houses, small cottage industries, and non-disruptive commercial operations supplying services to the zone,
  - Buildings for the self-employed such as physicians, dentists, lawyers, architects and engineers and for other independent contractors, who pursue their occupation similarly,
  - Buildings and structures for educational, religious, cultural, social, healthcare and sports facilities.
- **Exceptional Permissible Uses:**
  - Agricultural and horticultural production, trade and crafts on behalf of the livelihood of the residents,
  - Enterprises providing accommodation and other non-disruptive businesses,
  - Administrative buildings,
  - Filling stations,
  - Cinema Halls.
- **Prohibited Uses:**
  - Medium and large industries which affect the environment (air, water, surface),
  - Conversion of existing buildings into lodge or hotel without prior approval of municipality concerning provision for necessary parking,
  - Construction of headquarters of governmental and semi-governmental offices.

#### 4) **Core Zones and Old Settlements (Co)**

- The **Core Zones** are of historical, architectural or cultural importance and for this reason need lasting protection. Core Zones are intended to provide space for housing and for accommodation of businesses that do not exert a disruptive effect on disrupt the residential function or any religious site.
- **Permitted Uses:**
  - Residential buildings,
  - Business premises and office buildings,
  - Retailing operations, restaurants and businesses providing accommodation,
  - Essentially non-disruptive businesses of other types, workshops, handicrafts, and small cottage industries,



- Buildings for the self-employed such as physicians, dentists, lawyers, architects, and engineers and for other independent contractors, who pursue their occupation in a similarly.
  - Buildings and structures for educational, religious, cultural, social, healthcare and sports facilities.
- **Restricted Uses:**
    - Activities that affect or pollute the religious, cultural, and physical environment,
    - Storage and commercial handling of inflammable materials such as gas, petrol, firewood, coal, kerosene, explosives, and chemicals,
    - Commercial video shows, hoarding boards (digital and others)
    - Shops selling construction materials such as cement, rods, bricks, zinc-sheets, etc.,
    - Shops selling fish, meat, and workshops for repair of bicycle, motorcycle, car, pushcart, etc.
    - Workshops or industries relating to grill and welding,
    - Industry relating to farming chicken, ducks, or animals (cow, buffalo, pig etc.)
    - Wall painting and posters, banners and cloth paintings

## 5) Commercial Zones (C)

- **Commercial Zones** are intended primarily to provide space for commerce, central business, major wholesale and retail activities, and administrative and cultural institutions.
- **Permitted Uses:**
  - Commercial, office and administrative buildings,
  - Retailing operations, public houses and restaurants, businesses providing accommodation and places of public entertainment,
  - Essentially non-disruptive businesses of other kinds, workshops, and handicrafts,
  - Housing on upper floors,
  - Buildings for the self-employed such as of physicians, dentists, lawyers, architects, and engineers and for other independent contractors, who pursue their occupation similarly,
  - Buildings and structures for educational, religious, cultural, social, healthcare and sports facilities.
- **Exceptional Permissible Uses:**
  - Filling stations.
- **Prohibited Uses:**
  - Poultry, pig farming and animal husbandry,
  - Grill and motorcycle repair work shops on the side of the road,
  - Medium and large- scale industries affect the environment (air, water, surface).

## 6) Institutional Zones (In)

- Institutional **Zones** are intended exclusively to accommodate buildings and structures used for governmental, Semi-governmental other public uses.
- **Permitted Uses:**
  - Office and administrative buildings,
  - The Accommodation providing buildings,
  - Buildings and structures for religious, cultural, social, health-care, education and sports facilities.

## 7) Industrial Zones (I)

- Industrial Zones are intended exclusively to accommodate commercial operations, particularly commercial operations of kinds, which would not be permitted in otherland-use zones. Industries that may cause water and air pollution shall not be allowed within the range of 500 Meters from the residential zones.
- Permitted Uses:
  - Commercial operations of all types, storage yards and public enterprises,
  - Commercial premises, office and administration buildings,
  - Filling stations.
- Exceptional Permissible Uses:
  - Housing for supervisory personnel and personnel on stand-by duty, and for proprietors and operations managers,
  - Buildings for the self-employed such as physicians, dentists, lawyers, architects and engineers and for other independent contractors, who pursue their occupation similarly,
  - Buildings and structures for religious, cultural, social, health-care and sports facilities.

## 8) Special Zones (S)

- Zones to be marked and designated as special zones are those zones, which differ significantly from the other specific land use zones. Where zones are designated as special zones, the specific function and the type of use shall be stated with the designation. Special Zones may include in particular:
  - Zones of tourism, such as zones providing accommodation for visitors,
  - Religious and military areas,
  - Zones for research and development and the use of renewable energy sources, such as hydropower, solar energy and biomass
  - Quarries.

## 1.2.12 Road Construction

### 1. Brief Concept of Road Cross-Section

A road cross section is a vertical slice of a road, showing the different layers of the road and the surrounding terrain. The National Road Standard, 2076 of Nepal specifies the minimum width and other design features of road cross sections for different types of roads in Nepal.

The width of a road cross section is determined by the volume of traffic that the road is expected to carry. For example, a national highway that is expected to carry a high volume of traffic will have a wider cross section than a local road that is expected to carry a lower volume of traffic.

The other design features of a road cross section include the following:

**The carriageway:** This is the part of the road that is used for the movement of vehicles. The carriageway is typically made of asphalt or concrete.

**The shoulders:** These are the areas on either side of the carriageway that are used for parking and for emergency stopping. The shoulders are typically made of gravel or earth.

**The side drains:** These are the channels that are used to collect and carry away rainwater from the road surface.

**The verge:** This is the area between the side drains and the surrounding terrain. The verge is typically made of grass or other vegetation.

The National Road Standard, 2076 of Nepal also specifies the materials that can be used for different parts of a road cross section. For example, the carriageway must be made of asphalt or concrete, and the shoulders must be made of gravel or earth.

The road cross section is an important part of the design of a road. It ensures that the road is safe and efficient for the movement of vehicles.

Here are some additional details about the road cross sections specified in the National Road Standard, 2076 of Nepal:

The carriageway width for national highways is typically 7.5 meters, while the carriageway width for district roads is typically 5 meters.

The shoulders are typically 1-meter-wide on either side of the carriageway.

The side drains are typically 0.5 meters wide and 0.3 meters deep.

The verge is typically 1 meter wide.

The road cross sections specified in the National Road Standard, 2076 of Nepal are designed to meet the needs of different types of roads in Nepal. By following these standards, road engineers can ensure that roads are safe and efficient for the movement of vehicles.

## 2. Classification of Roads

- 1) For the purpose of geometric design urban roads are classified into four categories considering function of the road and traffic level.
  - a. Arterial roads (Path)
  - b. Sub-arterials roads (Sadak)
  - c. Collector roads (Marg)
  - d. Local roads (Upa-Marg)
- 2) Functions of different categories of roads are given below.

### a) Arterial roads (Path)

- These roads are generally meant for through traffic usually on a continuous route. These along with expressive ways (where they exist), serve as the principal network for through traffic flow.
- Significant intra-urban travel such as between Central Business Districts (CBD) and outlying residential area or between major sub-urban centers is served by this facility. Parking, loading, and unloading activities are generally restricted and regulated. Pedestrians are allowed to cross only at intersections or the designated crossings. These roads generally are spaced less than 1.5 km in highly developed central business areas and at 8 km or more in sparsely developed urban fringes. Typical sections of Arterial are shown in the figures given below:

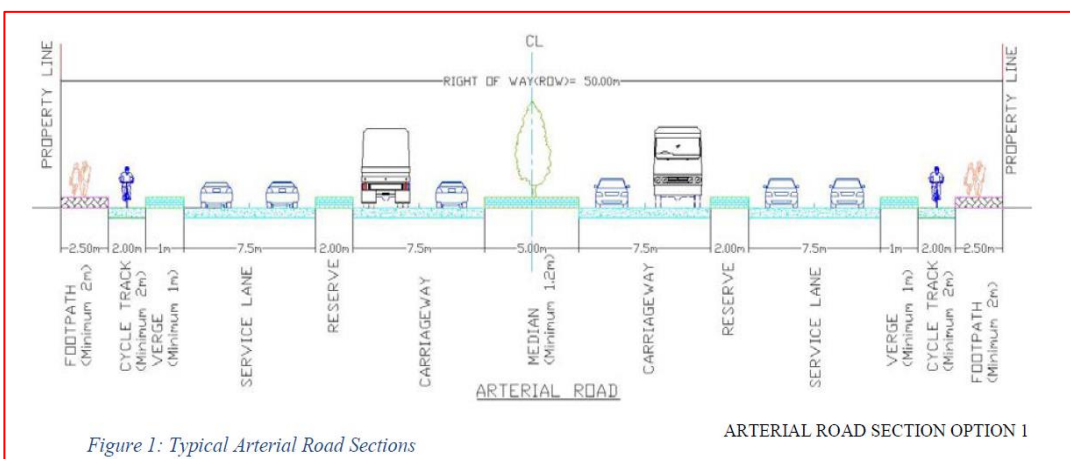
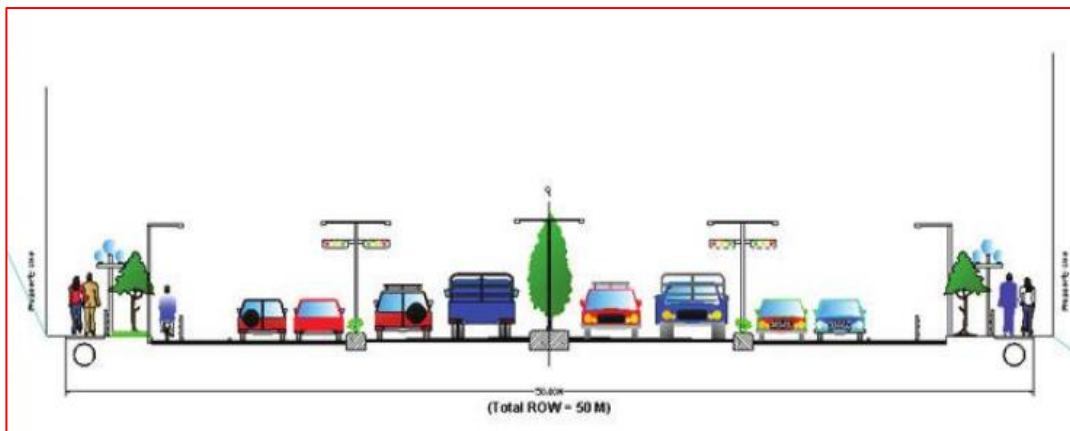
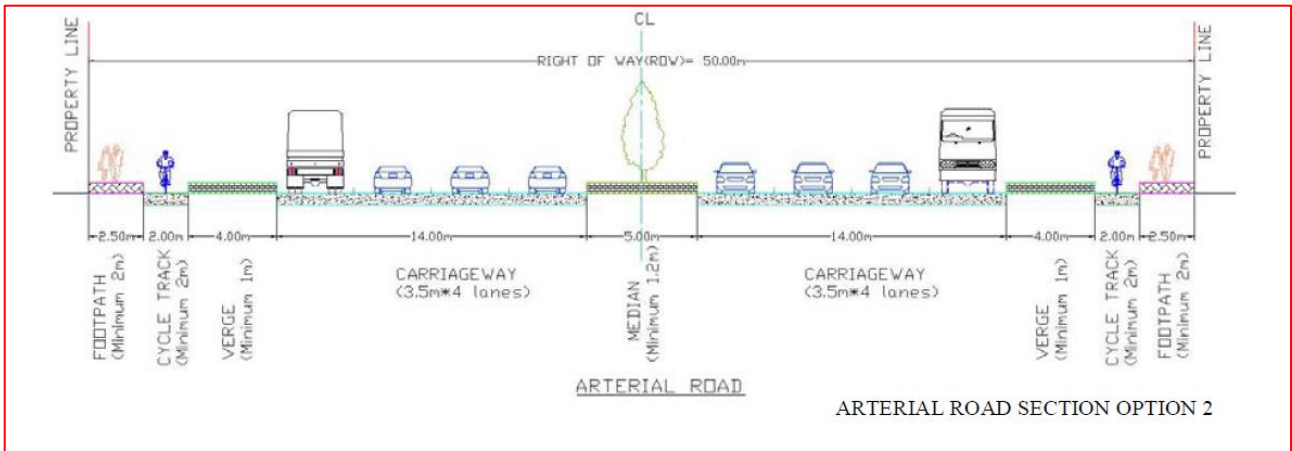
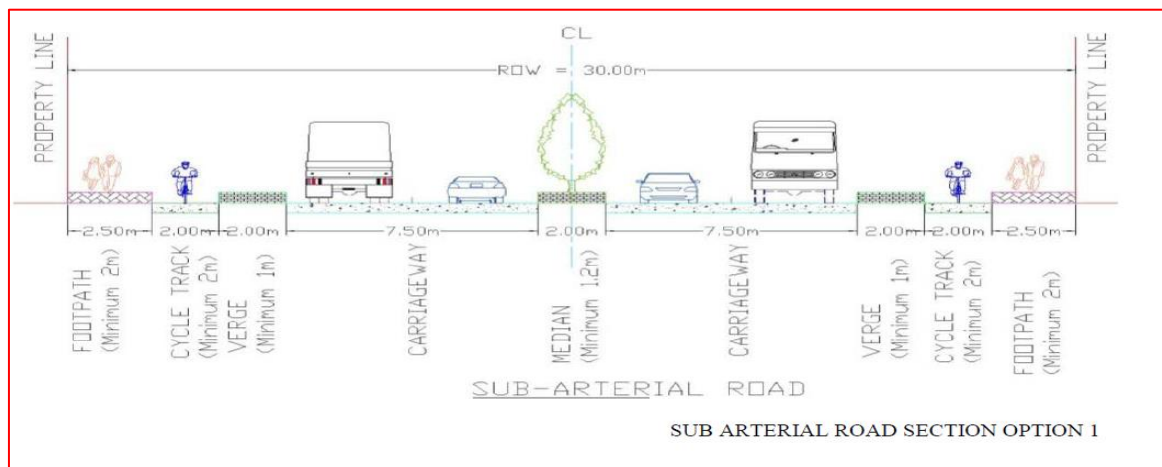

Figure 1: Typical Arterial Road Sections



**b) Sub-Arterial roads (Sadak)**

- These are roads of somewhat lower level of travel mobility than the arterial roads. The emphasis on access to adjoining area is more in case of these roads than in case of arterial roads. Parking loading and unloading are usually restricted and regulated. There spacing varies from about 0.5 km in Central Business Districts (CBD) to 3.5 km to 5 km in the suburban fringe. Pedestrians are allowed to cross only at intersections or at the designated crossings. Typical sections of Sub-Arterial Road are shown in the figures given below:



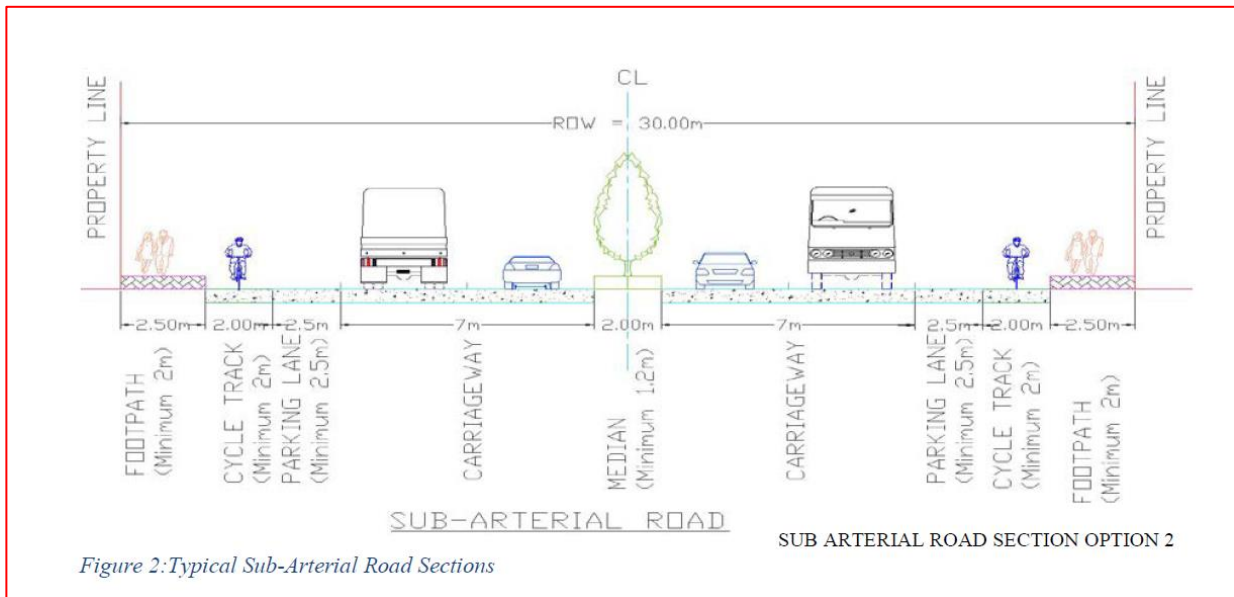
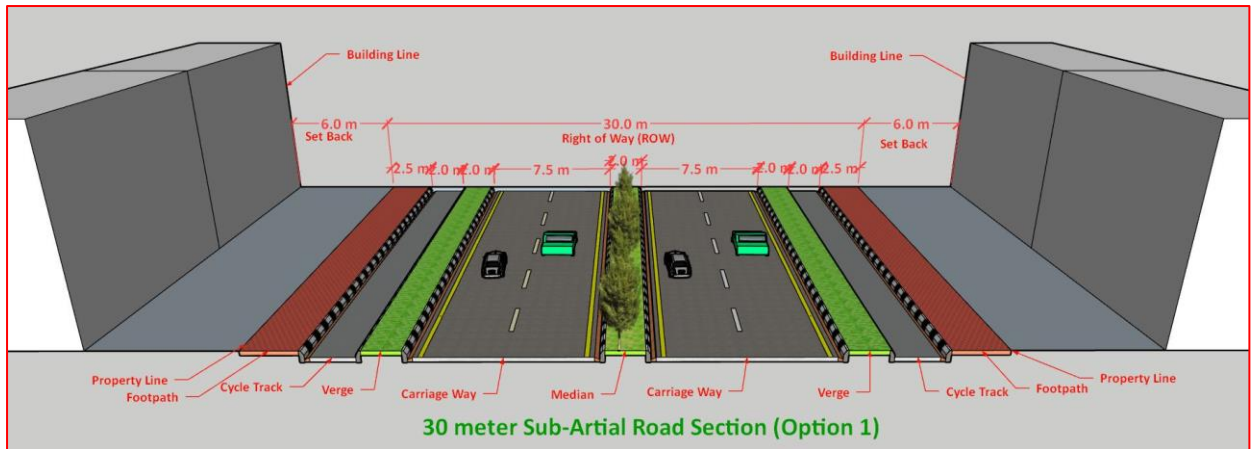

### c) Collector road (Marg)

- A collector road is one intended for collecting and distributing the traffic to and from local roads and for providing access to arterial/ sub-arterial road. They may be located in residential neighborhoods, business areas and industrial areas. Normally full access is allowed on these roads from abutting properties. Typical section of Collector Road is shown in the figure given below:



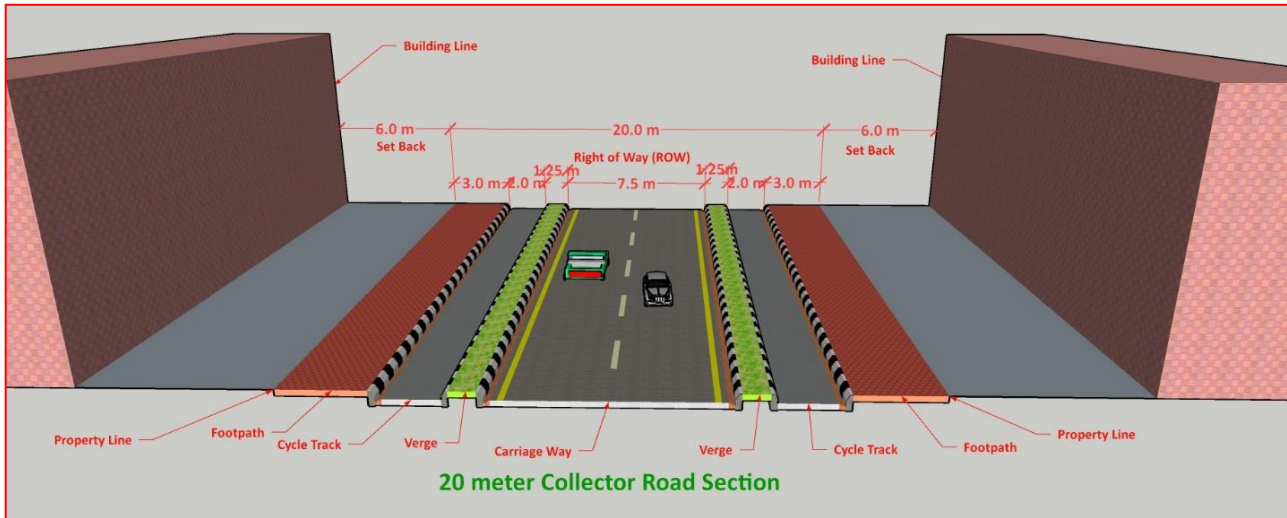
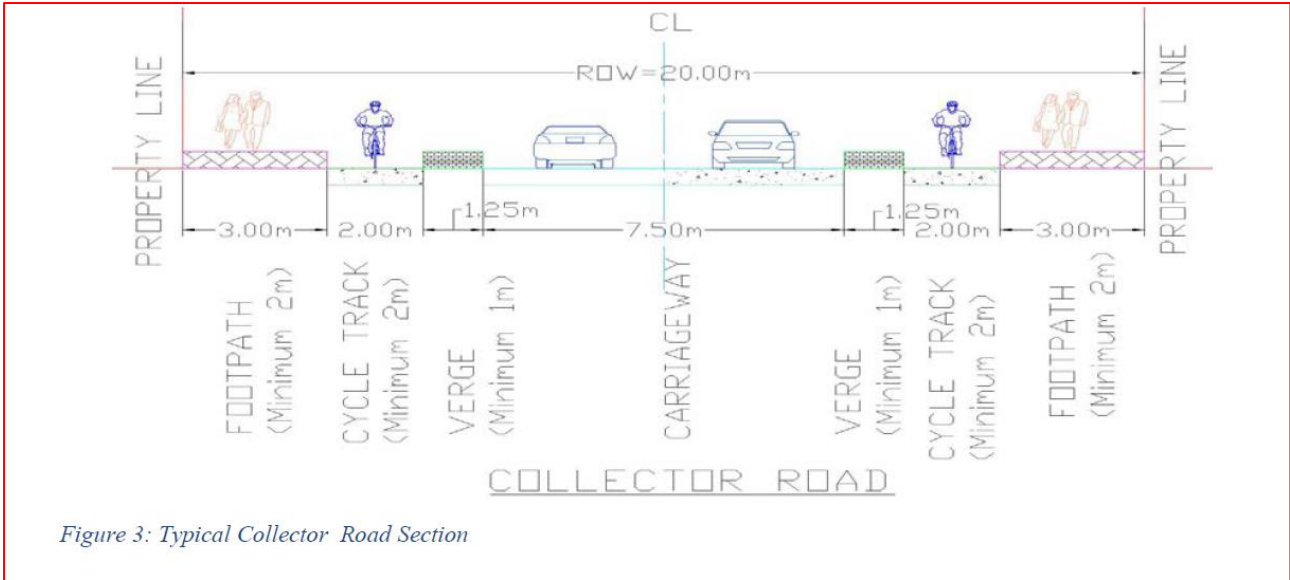

**d) Local road (Upmarg)**

- A local road is one primarily intended for access to residence, business, or other abutting property. Such a road normally does not carry large volume of traffic. The traffic carried either originates or terminates or terminates along its length. A local road may be residential, commercial, or industrial, depending upon the prominent use of the adjoining land. Typical section of Collector Road is shown in the given figure:

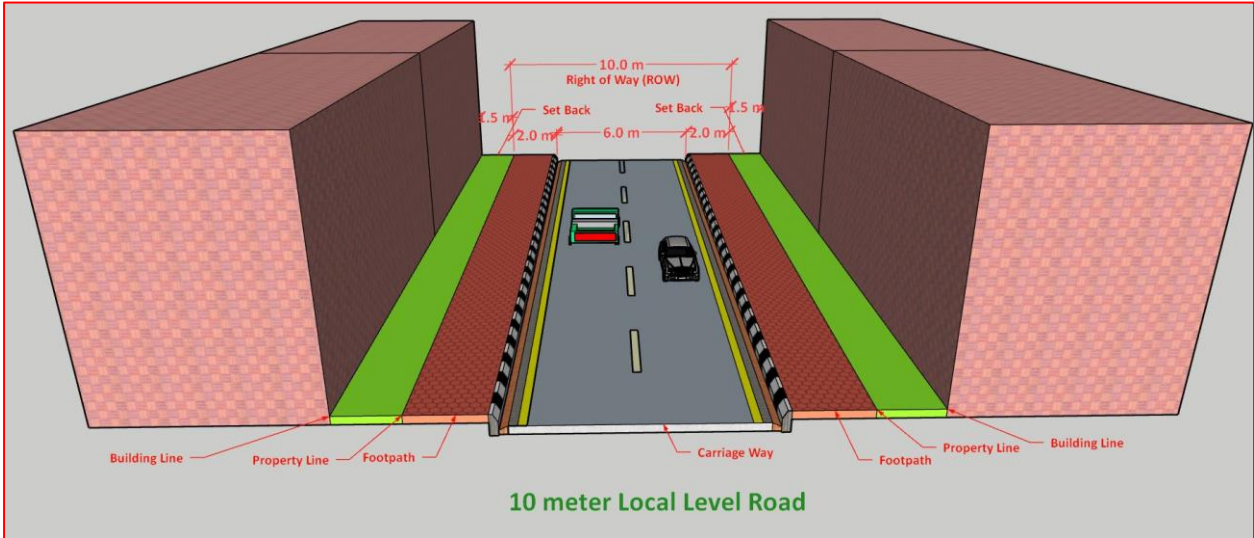
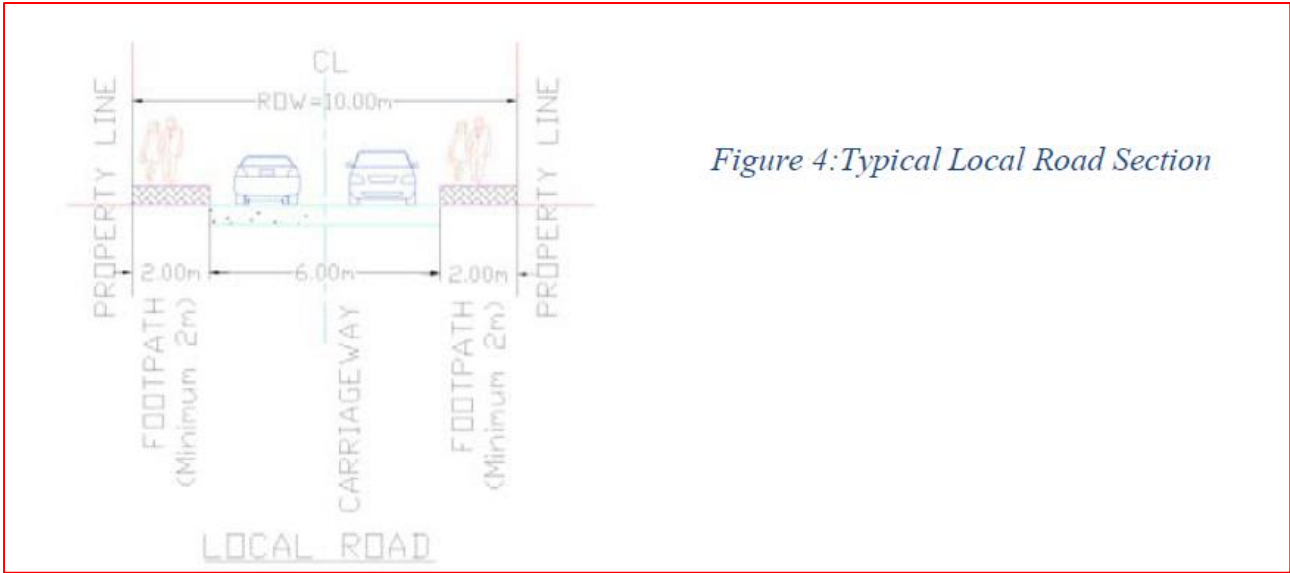

Source : Nepal Urban Road Standard, 2019



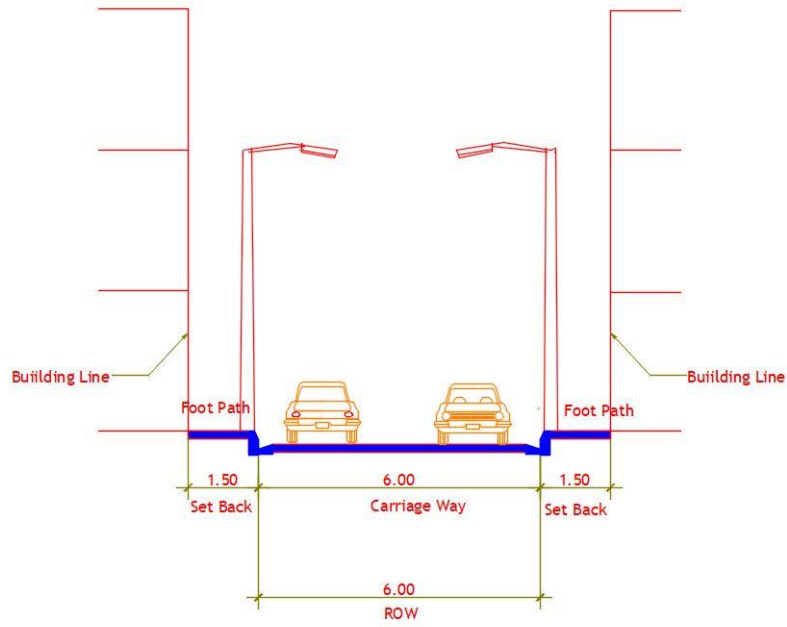

**TYPICAL CROSS SECTION OF 6 METER WIDE MUNICIPAL ROAD**

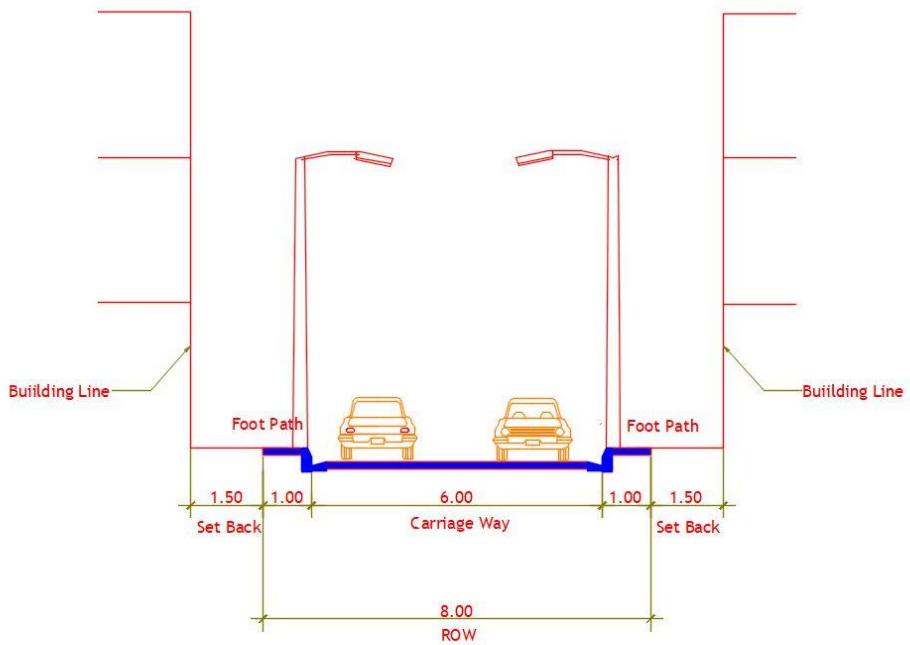

**TYPICAL CROSS SECTION OF 8 METER WIDE MUNICIPAL ROAD**

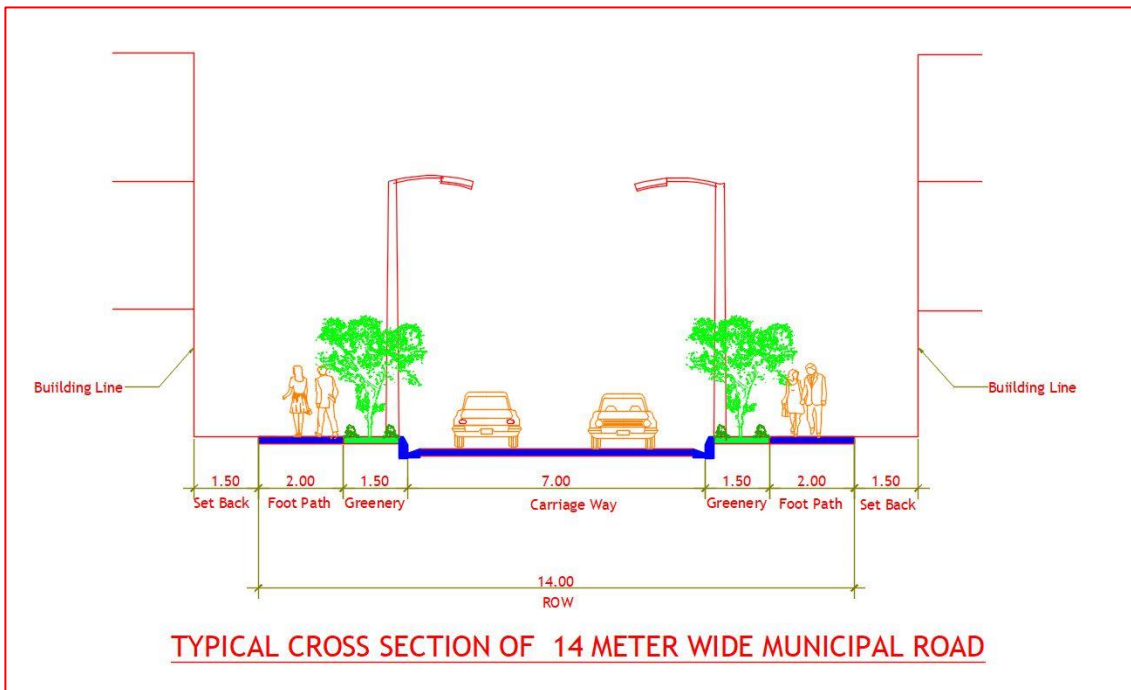
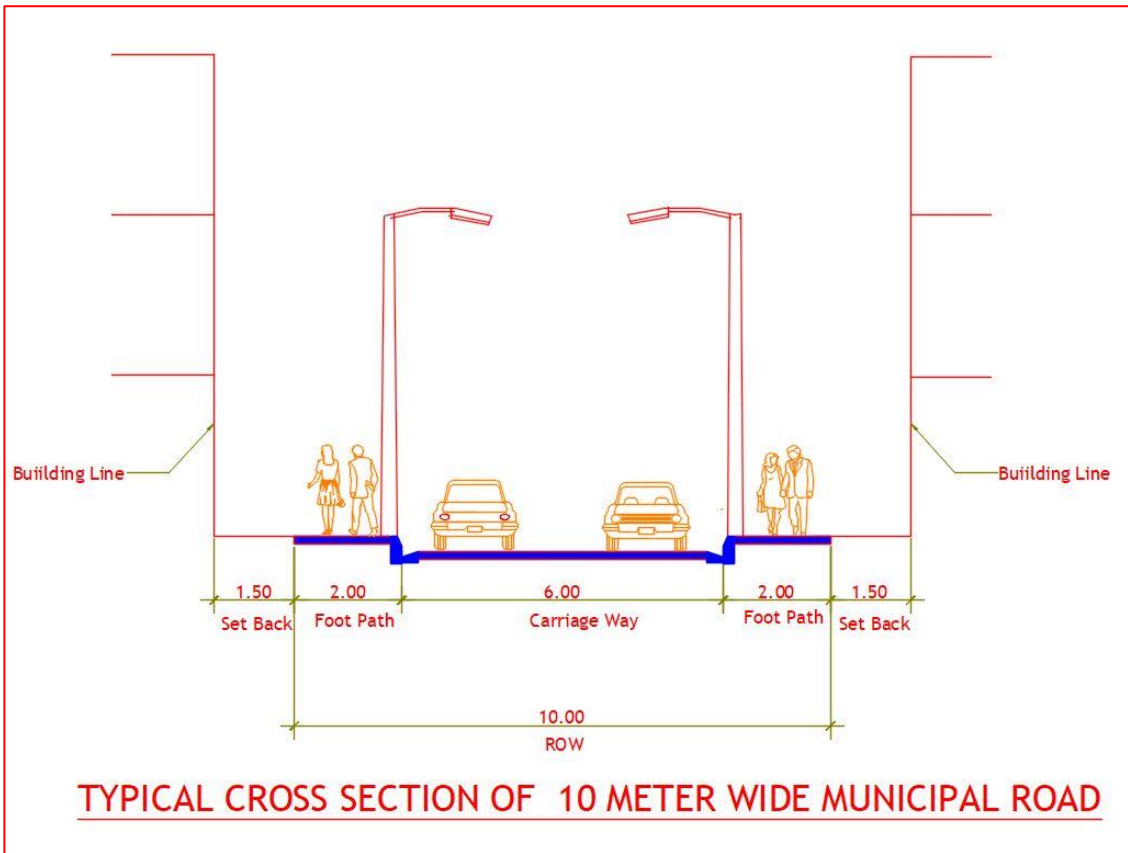

Road design and construction are influenced by various planning regulations, including:

**i) Road Classification and Functional Hierarchy:**

- Planning regulations classify roads based on their function and importance, such as national highways, regional roads, urban roads, and rural roads. Each classification has specific design standards and requirements.
- The regulations specify the minimum right-of-way width, number of lanes, and design speed for different road classes. These factors influence the geometric design of the road, including the width of lanes, shoulders, and median.

**ii) Pedestrian Facilities:**

- Planning regulations in Nepal emphasize the provision of safe and accessible pedestrian facilities.
- Sidewalks: The regulations may require sidewalks on both sides of urban and major rural roads. They specify the minimum width, materials, and slopes to ensure pedestrian safety and accessibility.
- Crosswalks and Pedestrian Signals: Regulations require marked crosswalks at intersections and pedestrian signals at appropriate locations to facilitate safe pedestrian movement.

**iii) Bicycle Infrastructure:**

- Planning regulations promote the inclusion of bicycle infrastructure to encourage cycling as a sustainable mode of transportation.
- Bike Lanes: The regulations may require the provision of dedicated bike lanes or shared lanes (where bike and vehicle traffic share the same space) on urban and major rural roads. They specify the minimum width, separation from vehicular traffic, and signage requirements.
- Bicycle Parking: Regulations may also specify the provision of secure and convenient bicycle parking facilities at various locations, such as transit stops, commercial areas, and public buildings.

#### iv) Green Spaces and Landscaping:

- Planning regulations in Nepal emphasize the integration of green spaces and landscaping within road projects.
- Tree Plantation: Regulations may require the planting of trees along roads to provide shade, improve air quality, and enhance aesthetics.
- Storm water Management: The regulations may include provisions for incorporating green infrastructure elements, such as bioswales, rain gardens, or permeable pavements, to manage storm water runoff and promote sustainable drainage.

#### v) Safety and Access Management:

- Planning regulations aim to enhance road safety and manage access points along roads.
- Intersection Design: Regulations provide guidelines for intersection design, including lane configuration, turning radii, signalization, and pedestrian safety measures.
- Access Control: The regulations may define access management strategies, such as limiting direct driveways on busy roads, to ensure safer and more efficient traffic flow.

#### vi) Construction Standards:

- Planning regulations specify construction standards for road projects, including materials, thicknesses, compaction requirements, and quality control measures.
- Drainage Systems: Regulations may outline the design and construction of drainage systems, including culverts, ditches, and storm water outlets, to manage surface water runoff effectively.
- Road Markings and Signage: The regulations provide guidance on road markings, signage, and lighting requirements to ensure proper guidance and safety for road users.

Some general guidance on the permissible materials and designs commonly used in planning By-laws for road construction, including sidewalks, bike lanes, and green spaces.

#### **Sidewalks:**

**Materials:** Generally, sidewalks are constructed using concrete or asphalt.

**Width:** Sidewalk width requirements may vary, but a typical minimum width is around 1.5 meters (5 feet) to accommodate pedestrians comfortably.

**Slope:** Sidewalks should have a gentle slope towards the road to ensure proper drainage and accessibility for people with disabilities.

**Crosswalks:** Sidewalks should be connected with properly marked crosswalks at intersections to facilitate pedestrian safety.

### **Bike Lanes:**

**Materials:** Bike lanes can be constructed using asphalt, concrete, or specialized bike lane surfacing materials.

**Width:** The width of bike lanes may vary, but a typical minimum width is around 1.5 to 2 meters (5 to 6.5 feet) to accommodate cyclists safely.

**Separation:** Bike lanes can be separated from vehicular traffic using painted lines, physical barriers, or a combination of both, depending on local regulations.

**Signage:** Proper signage indicating the presence of a bike lane and sharing the road with cyclists should be provided.

### **Green Spaces:**

**Landscaping:** Incorporate green spaces alongside roads, including trees, shrubs, and plants, to enhance aesthetics, provide shade, and contribute to environmental sustainability.

**Storm water management:** Design green spaces to facilitate stormwater infiltration and minimize runoff by implementing measures such as bioswales, rain gardens, or permeable pavements.

**Pedestrian amenities:** Consider installing benches, pedestrian-friendly lighting, and other amenities within green spaces to promote their use and improve pedestrian comfort.

**Maintenance:** Include provisions for regular maintenance and upkeep of green spaces to ensure their long-term viability.

## **PART TWO: NATIONAL BUILDING CODE SYSTEM IN NEPAL**

## 2.1 Earthquake Risk in Nepal

### 2.1.1 General Introduction

#### 1. INTRODUCTION

- 1) Nepal is ravaged by multiple natural hazards annually resulting in significant number of loss of lives and properties. Epidemics, floods, and landslides are among the most frequent natural hazards with high magnitudes and intensities occurring throughout the country. Earthquake, cyclonic wind, thunderstorm, drought, famine, cloudburst, fire, avalanche is often recurring natural disasters in the country. In terms of vulnerability to natural disasters, UNDP/BPCR has ranked Nepal as the eleventh in terms of risk from earthquakes and thirtieth in terms of risk from flood (UNDP/BCPR 2004).
- 2) Nepal's location in a highly active tectonic region of the Himalayan belt has increased the risk of earthquake disaster in the region. The subduction of Indian plate under the Tibetan plate is considered as the major source of seismicity in the region. Over the last century, great earthquakes in the Himalayan region occurred in 1803, 1833, 1897, 1905, 1934 and 1950 (Bilham, Gaur, and Molnar 2001). Seismic records showed the 1833 earthquake in Nepal, 1879 earthquake in Shilong, 1905 earthquake in Kangra, 1934 earthquake in Bihar-Nepal and 1950 earthquake in Assam also caused deaths of thousands of people.

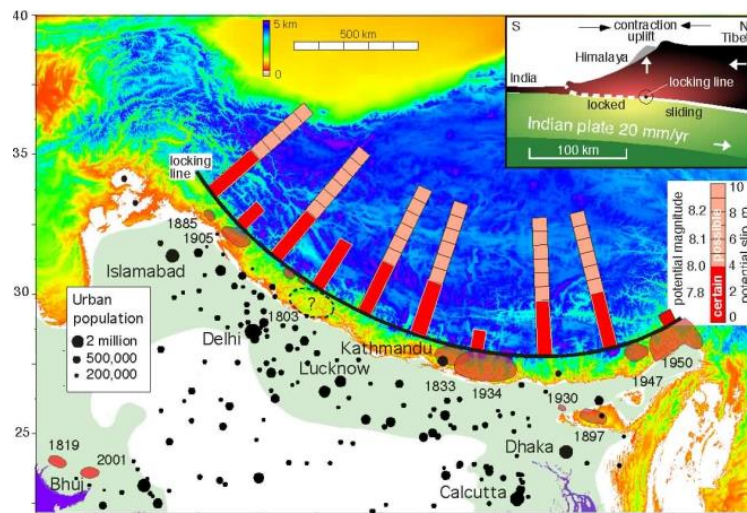

Figure 1 Estimated slip potential along the Himalaya and urban populations south of the Himalaya (Bilham, Gaur, and Molnar 2001)

- 3) Seismic records for Nepal date back to 1255 and since that time several destructive earthquakes have occurred in 1408, 1681, 1810, 1833, 1866, 1934 and 2015. The 1934 Bihar-Nepal earthquake with magnitude of 8.4 took a toll of 4,300 people, destroying about 20 percent of all structures and damaging another 40 percent of buildings in Kathmandu Valley. This earthquake was believed to rupture a 200-300 km long segment to the east of Kathmandu (Pandey and Molnar 1988). In recent decade, Nepal experienced four major earthquakes: a 6.5 magnitude quake in Bajhang district on 29 July 1980 that killed 178 people

and destroyed about 40,000 buildings and a 6.6 magnitude quake in Udayapur district that killed 721 people and destroyed 64,467 buildings.

- 4) Similarly, an earthquake of 6.9 Richter Scale hit at eastern border of Nepal between Taplejung and Sikkim on 18 September 2011. The earthquake had affected eight districts of eastern region caused 5000 building totally collapsed and 6500 buildings partially damaged including many school buildings.
- 5) On 25 April 2015, a huge 7.8 magnitude earthquake (Gorkha earthquake) struck Barpak in the historic district of Gorkha, about 76 km northwest of Kathmandu. Nepal had not faced a natural shock of comparable magnitude for over 80 years since the Bihar earthquake. And numerous aftershocks have occurred since the Gorkha earthquake, the largest aftershock is a magnitude 7.3 on May12, 2015. The Gorkha earthquake and Aftershocks caused massive damages and losses, a lot of collapse of the buildings of high vulnerability which were increased the number of death. Remarkable and regrettable damages extended many Historical Buildings including World Heritage sites. A damage and loss assessment showed that over 8,831 people lost their lives and 22,309 were injured. An over 602,000 private houses and 2,600 public buildings were completely collapsed. 285,000 private houses and 3,700 public buildings were damaged partially. 19,000 classrooms were completely damaged and more than 11,000 classrooms were damaged partially.
- 6) In 2005, the Western Himalaya was hit by an earthquake with magnitude 7.4 killing more than 74,000 people in Pakistan and India. The location of ruptured areas shows a gap along the mountain range between the location of the 1905 Kangra and 1934 Bihar-Nepal earthquakes. It is believed that this region has not experienced such an earthquake since the last large earthquake. This portion of the arc is thus referring to as a '*seismic gap*' (Figure 2), a potential location for the next large earthquake. This earthquake scenario evidently indicates that the entire Himalayan belt is one of the most vulnerable zones in terms of seismic hazard. The works on fault modelling (Chamlagain and Hayashi 2007) of Nepal Himalaya has shown continuous accumulation of elastic strain to reactivate older geological faults to generate earthquake of different magnitude. Moreover, several other lines of evidence (e.g. neo tectonic, geomorphological, geophysical, geological, and seismological) also show that one or more mega-earthquakes may be overdue in a large fraction of the Himalaya (probably area between Kathmandu and Dehradun), threatening millions of people in the region.



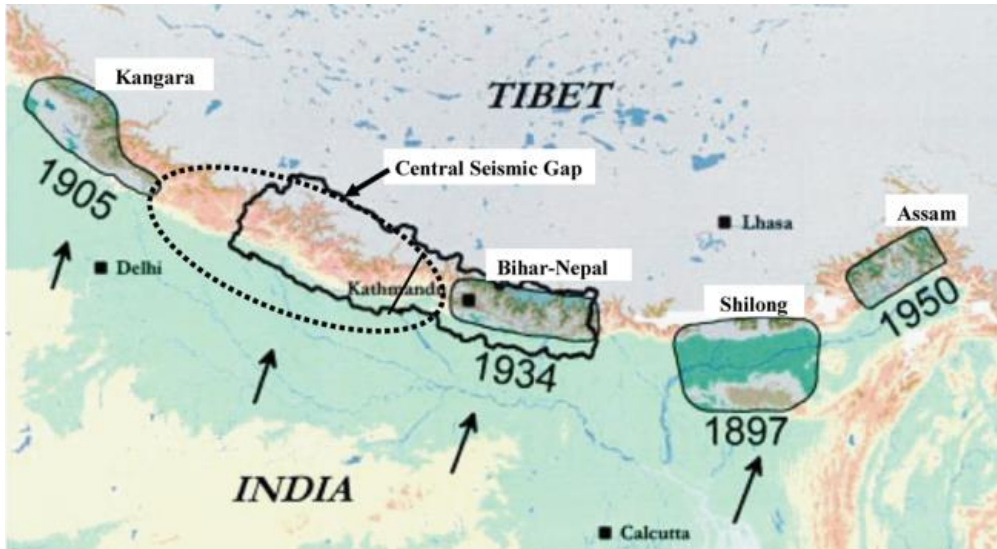

Figure 2. Distribution of probable rupture zones of 1879, 1905, 1934 and 1950 earthquakes along the Himalayan arc. Modified from (Yeats and Lillie 1991; Yeats et al. 1992)

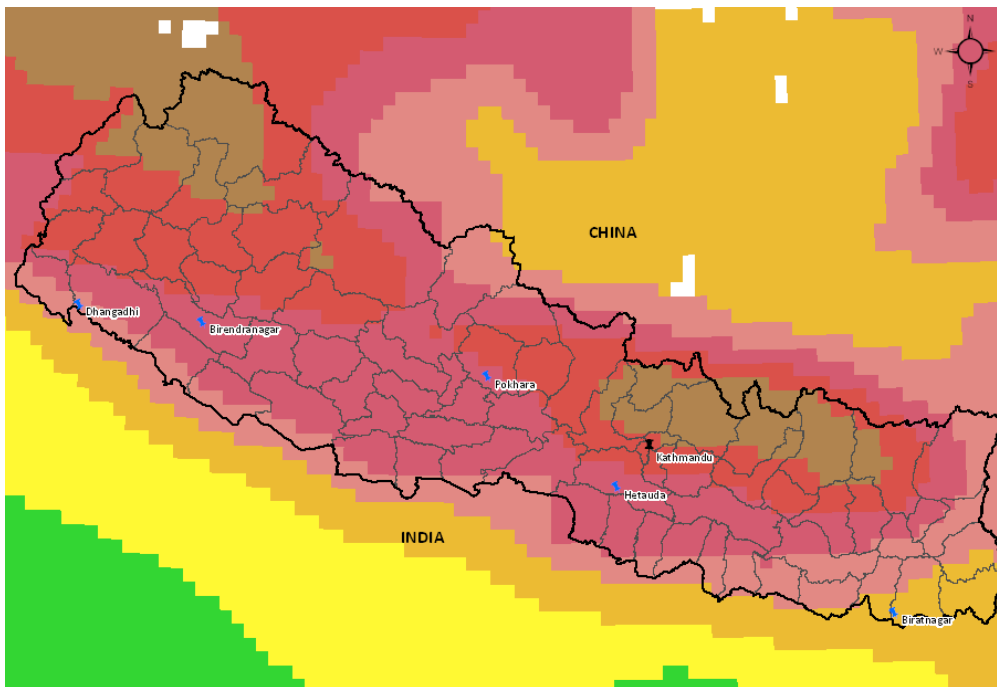

Figure 3. GSHAP seismic hazard map of Nepal [Adopted from (Giardini et al. 1999)]

- 7) The GSHAP seismic hazard map shows that the entire country falls in a high earthquake intensity region of seismic risk scale corresponding to MMI, IX and X. The far western and eastern mountainous regions are the most hazardous regions with rest of entire hilly and the Terai regions lying in a high earthquake hazard zone. The hilly regions and the southern Terai region are the most densely populated areas of the country with a probability of very high population loss in an event of a major earthquake in the region.
- 8) The level of risk has been increased further in our cities due to high urban growth rates and consequent high physical exposure and lack of preparedness. There are number of factors that

contribute to the configuration of risk in cities. Firstly, the location of the city in terms of geology and seismological hazard; secondly the urbanisation process which leads to the concentration of populations in risk-prone cities, and risk-prone locations within cities.



*Figure 4. Some pictures of Building Damages in Kathmandu during Earthquake of April 2015*



There have been a number of small-scale earthquakes in the western part of Nepal in recent months. November 9, in the morning, an earthquake of 6.6 magnitude occurred, with its center around the Khaptad National Park. Due to the earthquake, six people died and seven were injured when the building of the East Chowki Rural Municipality of Doti collapsed. Similarly, an earthquake of magnitude 5.9 occurred at 2:43 PM last Tuesday, on 24 January 2023 with the epicenter around Maula village in Bajura. The earthquake destroyed some houses and one person died. On 28<sup>th</sup> April 2023, an earthquake of magnitude 4.9 and 5.9 occurred againn in Bajuar District and damaged more than 156 buildings.

The western part of Nepal is located in a seismically active region. This region is part of the Himalayan arc, which is a region of active mountain building. The movement of tectonic plates in this region can cause earthquakes. The earthquakes in western Nepal have had a significant impact on the local people. Many people have been displaced from their homes due to damage to their buildings. The earthquakes have also caused economic hardship, as businesses have been closed and people have been unable to work.

The government of Nepal has been working to provide assistance to the people affected by the earthquakes. The government has provided food, shelter, and medical care to those in need. The government has also been working to repair damaged buildings. The earthquakes in western Nepal are a reminder of the seismic hazards that exist in this part of the world. The government of Nepal is working to reduce the risk of future earthquakes, but it is important for people in this region to be prepared for the possibility of an earthquake.



Building damaged during Earthquake of Nov 9, 2022, in Doti District



Building damaged during Earthquake of Nov 9, 2022, in Doti District



Building damaged during Earthquake of Jan 24, 2023 in Bajura District



Building damaged during Earthquake of April 28, 2023 in Bajuar District

## 2.2 Introduction of National Building Code

### 2.2.1 General Introduction

#### 1. Introduction

- 1) The earthquake of 6.7 Richter scale in 1988 that struck in eastern Nepal drew attention of the Ministry of Urban Development (Former Ministry of Physical Planning and works), need for changes and improvement in current building construction practices in Nepal. It was recognized and request of Government of Nepal, technical assistance from UNDP and UNCHS (Habitat) had set up a three-year program “Policy and Technical Support to the Urban Sector” within the ministry. Then the sub-project “National Building Code Development Project” (UNDP/UNCHS/(Habitat)NEP/88/054) was formulated in 1992-93 within the Department of Urban Development and Building Construction (DUDBC) (former Department of Buildings) including with the government counterpart from the department. The Project developed Nepal National Building Code of Nepal which included 20 volumes of the different kinds of the Codes.
- 2) The National Building Code (NBC) in Nepal is a comprehensive set of regulations that outlines the standards and requirements for the design, construction, and maintenance of buildings across the country. Its purpose is to ensure the safety, structural integrity, and resilience of buildings in Nepal, particularly in relation to seismic risks.

The NBC provides guidelines for various aspects of building construction, including structural design, materials, fire safety, electrical systems, plumbing, and accessibility. It incorporates seismic design principles, taking into account the specific seismic hazards prevalent in different regions of Nepal.

The main objectives of the NBC are to:

**Enhance Seismic Resilience:** The NBC aims to minimize the potential damage and loss of life caused by earthquakes by promoting the construction of buildings that can withstand seismic forces. It provides seismic design parameters, reinforcement techniques, and construction standards to improve the structural integrity and resilience of buildings.

**Ensure Public Safety:** The NBC prioritizes public safety by establishing guidelines for fire safety, building exits, emergency lighting, and other safety measures. It also addresses issues related to electrical systems, plumbing, and sanitation to ensure the well-being and health of building occupants.

**Promote Uniformity and Quality:** The NBC sets standardized guidelines and requirements for building construction, promoting uniformity and quality across different regions of Nepal. It helps prevent substandard construction practices, ensuring that buildings meet minimum safety standards and are suitable for their intended purposes.

**Facilitate Consistency and Compliance:** The NBC provides a common reference point for architects, engineers, contractors, and regulatory authorities involved in the building construction process. It helps streamline the approval process by facilitating consistent interpretation and application of building codes, ensuring compliance with the prescribed standards.

**Support Sustainable Development:** The NBC includes provisions for sustainable building practices, energy efficiency, and environmental considerations. It promotes the use of green building materials, energy-saving technologies, and proper waste management, contributing to sustainable urban development in Nepal.

Overall, the National Building Code plays a crucial role in guiding the design, construction, and maintenance of buildings in Nepal. By emphasizing safety, resilience, and quality, it aims to protect lives, enhance urban resilience, and promote sustainable development in the country.

- 3) Although too late, initiations have been taken to implement the National Building Code in municipalities of Nepal. Many municipalities have been implementing Nepal National Building code in building permit process. And DUDBC is strictly applying NBC in government buildings. Other municipalities and rural municipalities are trying to apply NBC gradually.
- 4) Department of Urban Development and Building Construction (DUDBC) had added three additional codes in 2003 besides the existing 20 volumes of the codes. They are Architectural (NBC 206), Sanitary (NBC 207) and Electrical code (NBC 208). After the Earthquake of 2015 NBC 202, 203, 204 and 206 have been updated. NBC 205: Mandatory Rules of Thumb for RC Buildings without masonry infill has been updated in 2012 as NBC 205: Ready to use detailing for RC Buildings without masonry infill. The present 23 volumes of codes have been formerly approved by the Government in the year 2003. The name list of Nepal National Building Codes is as follows:
  - 1) NBC 000: Requirement of State-of-the-Art Design and Introduction:
  - 2) NBC 101: Materials Specifications
  - 3) NBC 102: Unit Weight of Material
  - 4) NBC 103: Occupancy Load (Imposed Load)
  - 5) NBC 104: Wind Load
  - 6) NBC 105: Seismic Design of Buildings in Nepal
  - 7) NBC 106: Snow Load
  - 8) NBC 107: Provisional Recommendation on Fire Safety
  - 9) NBC 108: Site Consideration for Seismic Hazards.
  - 10) NBC 109: Masonry: Unreinforced
  - 11) NBC 110: Plain & Reinforced Concrete
  - 12) NBC 111: Steel
  - 13) NBC 112: Timber
  - 14) NBC 113: Aluminium
  - 15) NBC 114: Construction Safety
  - 16) NBC 206: Architectural Design Requirement.
  - 17) NBC 207: Electrical Design Requirements for (Public Buildings)
  - 18) NBC 208: Sanitary and Plumbing Design Requirements)
  - 19) NBC 201: Mandatory Rules of Thumb: Reinforced Concrete Building with Masonry Infill
  - 20) NBC 202: Mandatory Rules of Thumb: Load Bearing Masonry
  - 21) NBC 205: Mandatory Rules of Thumb: Reinforced Concrete Building without Masonry Infill
  - 22) NBC 203: Guidelines for Earthquake Resistance Building Construction: Low Strength Masonry
  - 23) NBC 204: Guidelines for Earthquake Resistance Building Construction: Earthen Buildings (Eb)

## 2. Short Description of Building Codes of Nepal

- 1) This National Building Code is the first such document prepared in Nepal and it is intended that its implementation be enforced through the Parliamentary Bill Act and concerned, local authority By-laws. Most countries which have successfully implemented building controls have only achieved it over a very long period which is normally measured in decades. The technical documents making up building regulations are normally the subject of a continual process of revision, correction, and expansion as per requirements. There is a strong movement towards uniform standards and many countries have adopted those of the International Standards Organization in some areas. Where it has been considered appropriate, the adoption of certain Indian Standards, with or without some modification has been made in this document. The degree to which national building codes and standards are enforced by law varies from country to country. In some countries, the national building code is taken by the law courts as a measure of good practice. India is one of the countries adopting such a system.
  
- 2) This first Nepal National Building Code has been produced by a team of Nepalese and international consulting engineers and architects and is based on the given term of reference. It deals primarily with matters relating to the strength of buildings. However, there are some chapters on site considerations and safety during construction and fire hazards. Each section of this Code has been drawn up as a draft Standard for possible adoption by the Nepal Bureau of Standards and Metrology. It has been proposed that the future revision and reissue of these sections be undertaken by the specialist committees brought together on a regular basis by the Bureau. This system which has been adopted in Nepal for a number of years, ensures that all special, general and public interest groups can give their full input to this important regulatory process. As of recent years, most of the uncontrolled building processes are rapidly producing structures of unacceptable standard and prone to the risk of damage and collapse under earthquake. The designs and personnel involved in the construction industry, industry, therefore, should adopt this code sincerely so as to achieve a meaningful improvement in that standard of building construction in Nepal.

## 2.3 National Building Codes of Nepal

### 1. NBC 000: Requirement of State-of-the-Art Design and Introduction:

- 1) Because the major thrust of the Code is aimed at the typical and most common buildings currently being erected in Nepal, it deliberately does not suggest as being practical for everyday consideration the sophisticated design philosophies and analytical techniques that are appearing in the codes of more wealthy countries. However, it is important that both Nepalese engineers and international consultants who can produce such designs in a routine fashion and can ensure that their designs can be built to the corresponding standards should not be prevented from doing so. Moreover, these structures should be seen to be meeting the Nepalese requirements with respect to minimum design loads and configuration. There is then no reason for any designer to ignore the Nepal regulations in their entirety. This part therefore describes some of the philosophy behind the selection of loads (in particular, the earthquake ones) and therefore allows the sophisticated designer and/or international designer to build up a design philosophy consistent with, and encompassing, the basic requirements. The onus shall be on the designer to prove to the permit issuing authority that the Nepal Code requirements have been met and/or exceeded.
- 2) It is important to note that the Nepal National Building Code's requirements for seismic resistant are, in many cases, more onerous than those commonly practiced in other countries of the region.

### 2. NBC 101: Materials Specifications

- 1) This Standard deals with the requisite quality and effectiveness of construction materials used mainly in the building construction. It also deals with the storage of materials where storage has relevance to strength. Since the quality requirements and test methods used to determine the quality are enumerated in the relevant materials standards, this standard provide a list of Nepal Standards (NS) for key materials used in the building construction. A list of related Indian Standards (IS) has been included for those materials for which Nepal Standards (NS) do not exist yet.
- 2) When NS or IS prepare Standards for other materials having a bearing on the strength characteristics of the buildings, or revised version of the existing Standard, these shall be deemed to be the requirement of this Standard. If it exists, the requirements of NS will govern and be mandatory unless the designer has based his design on a standard other than NS. The use of appropriate, adopted or new materials is encouraged, provided these materials have been proven to meet their intended purposes

### 3. NBC 102: Unit Weight of Material

- 1) This Nepal Standard for Unit Weight of Materials adopts the Indian Code IS:875 (Part 1) – 1987 Code of Practice for Design Loads (Other than Earthquake) for Buildings and Structures, Part 1, Dead Loads-Unit Weights of Building Materials and Stored Materials, (Second Revision). During the desk study of codes from various countries (Uniform Building Code, Indonesian Earthquake



Code, National Building Code of Indian and Yugoslavian Code, New Zealand Code) it was found that unit weight of very common types of materials were maintained the same in each country.

- 2) For country-specific materials, their variation in unit-weight with respect to those of similar materials in other countries was also found to be minimal. Because of the unavailability of specific unit weights of Nepalese materials for various uses, and because of the similarity of materials and their uses in Nepal and India, Indian Standard IS: 875 (Part I) -1987 has been recommended for adoption in Nepal.

#### **4. NBC 103: Occupancy Load (Imposed Load)**

- 1) This Nepal Standard for Occupancy Load adopts the Indian Code IS:875 (Part 2) - 1987 Code of Practice for Design Loads (Other than Earthquake) for Buildings and Structures, Part 2 Imposed Load, (Second Revision).
- 2) During the desk study of codes from various countries (Uniform Building Code, Indonesian Earthquake Code, The National Building Code of Indian, the Yugoslavian Code and the New Zealand Code) it was found that recommended occupancy loads were more or less similar. In the absence of any specific information indicating that typical Nepalese occupancy loads are unusually different, the Indian Standard IS: 875 (Part 2) -1987 has been recommended for adoption in Nepal because of the similarity of the situations in Nepal and India.

#### **5. NBC 104: Wind Load**

- 1) This Nepal Standard on "Wind Load" comprises the India Standard IS:875 (Part 3) 1987: Code of Practice for Design Loads (Other Than Earthquake) For Buildings and Structures (Second Revision) with amendments as set out herein. These amendments have been necessary to ensure the requirements of Nepalese context. Particularly the wind zoning map of Nepal'
- 2) Wind speed is monitored at only a few stations in Nepal. The average monthly wind speed data recorded at a particular time of the day is available from 40 stations distributed in various parts of the country. Of these, the station at Tribhuvan International Airport 1030) records the average daily wind speed, maximum hourly gust and maximum gust. The data from this station, however, is not continuous and this information is available only for the period 1971 to 1975 and 1985 to 1986. For the 1985-1986 periods, only the average monthly wind speed is available. This is published in book-form. The general data is available in a booklet published by the Department of Hydrology and Meteorology.

#### **6. NBC 105: Seismic Design of Buildings in Nepal**

- 1) The attempt for development of any code for seismic design in Nepal started in Nineties following the Udayapur earthquake of 1988. Consequently, the Nepal National Building Code NBC 105 Seismic Design of Buildings in Nepal was published in 1994. Since then, the seismic code has not been reviewed and updated till the moment. In view of the development in research and technology and new knowledge learnt from various large earthquakes in the



region and other parts of the world in last 24 years, the need for updating of the document was tremendously felt.

- 2) The Department of Urban Development and Building Construction (DUDBC), Ministry of Urban Development (MoUD) had initiated the preparation for the updating of the NBC 105: 1994 Seismic Design of Buildings in Nepal, however, the process was formally started only after the Gorkha Earthquake of 2015 April 25 and the following aftershocks. The process of updating the NBC 105: 1994 Seismic Design of Buildings in Nepal was started under the initiative of the Central Level Project Implementation Unit (CLPIU) of the ADB financed Earthquake Emergency Assistance Project (EEAP) under the Ministry of Urban Development (MoUD). The revision of the NBC 105: 1994 as the major code guiding seismic design of buildings in Nepal, is one of the important activities to be implemented under the EEAP.
- 3) This Standard is the first revision of the Nepal National Building Code 105: 1994 Seismic Design of Buildings in Nepal, prepared by the Working Group of Consultants formed by the Central Level Project Implementation Unit (CLPIU) of the Earthquake Emergency Assistance Project (EEAP) under the Ministry of Urban Development (MoUD) and later transferred to the National Reconstruction Authority (NRA), the Government of Nepal. This standard after due approval will supersede the earlier 1994 edition of the NBC 105 Seismic Design of Buildings in Nepal.
- 4) The objective of this Standard is to provide designers with general procedures and criteria for the structural design of buildings prevalent in the Federal Republic of Nepal considering the seismicity in the parts of the country. This document outlines analysis and design methodology that is applied in accordance with the established engineering principles.
- 5) This code covers the requirements for seismic analysis and design of various building structures to be constructed in the territory of the Federal Republic of Nepal. This code is applicable to all buildings, low to high rise buildings, in general. Requirements of the provisions of this standard shall be applicable to buildings made of reinforced concrete, structural steel, steel concrete composite, timber, and masonry.
- 6) For Base-isolated buildings as well as for buildings equipped and treated with structural control can be designed in reference to specialist literatures.

## **7. NBC 106: Snow Load**

- 1) This Nepal's standard on "snow load" comprises the Indian standard is: 875 (part 4) 1987: code of practice for design loads (other than earthquake) for buildings and structures (second revision) with amendments as set out herein.
- 2) Most of the mountainous districts of Nepal experience snowfall two to three times a year. The districts that experience snowfall is Darchula, Bajhang, Humla, Mugu, Jumla, Dolpa, Rukum, Mustang, Manang, Gorkha, Rasuwa, Sindhupalchok, Dolakha, Solukhumbu, Sankhuwasabha and Taplejung. The depth of snow that occurs in these places is variable. The country can broadly be divided into five categories based on the physiographic regions. Of these five physiographic regions, the Terai, the Siwaliks and the Middle Mountains do not experience snowfall. The region falling in the high mountains, however, gets snow during two or three months of a year. The High Himalayas always have snow cover throughout the year.

## **8. NBC 107: Provisional Recommendation on Fire Safety**

- 1) This Standard, with due consideration to the severe limitations on the issue of fire protection in Nepali conditions, takes a modest approach. It deals only with the minimum requirements of exits from and access to ordinary residential buildings from the fire safety point of view.
- 2) Designers are encouraged, wherever possible, to incorporate higher levels of fire safety in their designs by following other relevant reference, Standards or Codes.
- 3) This Standard provides fundamental requirements for fire safety in ordinary buildings. These requirements do not necessarily cover the fire safety provisions needed for other buildings. For the design of such other buildings, other relevant Codes and Standards which might be followed have been suggested.

## **9. NBC 108: Site Consideration for Seismic Hazards.**

- 1) This document sets out some of the factors to be considered during site selection for buildings in order to minimize the risks to the buildings from both primary and secondary seismic hazards. It also outlines the fundamental requirements for site investigation for the foundation design of buildings. The degree to which each factor should be considered will depend on the importance and size of the building under consideration. The document is particularly applicable for State of Art Design and Engineered buildings.
- 2) In general, the provisions of this standard should be applied to all buildings to be constructed in Nepal. The site considerations detailed out in this Standard shall be mandatory for all important buildings in Nepal. The State of Art Design and engineered buildings of all categories should carry an appropriate level of site investigation and formal reporting at the beginning of the design process, and it shall be incorporated in the permit application documents. Subject to the mandatory rules-of-thumb and/or advisory guidelines the designer should considered it as an indication of good practice and apply same as appropriate.

## **10. NBC 109: Masonry: Unreinforced**

- 1) This Code of Practice covers the structural design aspect of unreinforced masonry elements in the buildings.
- 2) It also deals with some aspect of earthquake-resistant design of buildings. References to seismic zoning, seismic coefficients, important factors, structural performance factors and performance coefficient are as per NBC 105-94 Seismic Design of Buildings in Nepal.

## **11. NBC 110: Plain & Reinforced Concrete**

- 1) This Nepal Standard comprises the Indian Code IS 456-1978 Code of Practice for Plain and Reinforced Concrete (Third Revision) amended so as to meet the conditions of Nepal.

- 2) In particular, these amendments have been necessary to ensure compatibility with the Nepal Standard NBC 105-1994: Seismic Design of Buildings in Nepal. This document contains the amendments that are to be made to IS 456-1978 for its use in Nepal.

## **12. NBC 111: Steel**

- 1) This Nepal Standard comprises the Indian Code IS 800-1984 Code of practice for General Construction in Steel (Second Revision) with amendments as set out herein. These amendments have been necessary to ensure compatibility with the Nepal Standard- Seismic Design of Buildings in Nepal.

## **13. NBC 112: Timber**

- 1) This standard covers the general principle involved in the design of structural timber in buildings. It also covers the specifications for structural timber for use in buildings including, classification of such timber into suitable grades, as well as nail joint timber construction.
- 2) The requirement of this section shall be applied in conjunction with the Indian Standard IS: 883-1970 Code of Practice for Design of Structural Timber in Building” (Third revision) and IS: 2366-1983 Code of Practice for Nail-Jointed Timber Construction (First Revision).
- 3) This standard provides a Code of Practice for the structural design of timber in buildings of Nepal.

## **14. NBC 113: Aluminium**

- 1) This document is not intended to be a definitive design standard. Rather it is a series of guidelines intended only for the designer of simple aluminium structures. Although the use of aluminum as a structural material in Nepal is likely to grow in the future, the current usage does not yet justify the preparation of a detailed Nepal Standard covering construction in aluminium.
- 2) Designers wishing to use aluminium as a structural material are referred to the relevant codes of other countries.

## **15. NBC 114: Construction Safety**

- 1) The purpose of this standard is to provide a reasonable degree of safety to construction-related personnel in building and civil construction works. Provisions of this Standard shall not be considered as contradictory to the provisions in the laws, By-laws and any other statutory requirements enforced by the appropriate authorities in Nepal.

- 2) The provisions in this standard are the minimum requirements that are to be adopted during building and other civil construction or demolition work.

### **16. NBC 206: Architectural Design Requirement.**

- 1) The ‘Architectural Design Requirement – 206’ also referred as ‘Architectural Code’ spells out minimum standards and requirements, the architects and engineers need to follow while designing a building in accordance with the principles stated in the Building Act–1998).
- 2) The principal focus of the code is on the safety of the occupants although it is also intended to maintain the minimum acceptable level of comfort & accessibility in a building.
- 3) It is recommended that anyone trying to use and understand the code go through each part in the order that they are given. However, for quick summary of requirements on any specific occupancy type one can directly refer to section 6 of the code.

### **17. NBC 207: Electrical Design Requirements for (Public Buildings)**

- 1) This code has been prepared having considered the provisions of Electricity Act 2049 and Electricity Rule 2050 up to date. This includes general guidance’s for Electrical wiring installation. Prevention of short-circuiting has been emphasized.
- 2) Utmost importance should be given in the installation of electrical wiring while preplanning and exchanging information among all concerned agencies from the earlier stages of the building works.
- 3) Due to the limited technical manpower the country's construction industry, the code has been simplified for the ease of use and implementation. It is hoped that with the development of the manpower and modernization of construction processes, it will be possible to release more sophisticated set of electrical wiring installation guidelines in future.

### **18. NBC 208: Sanitary and Plumbing Design Requirements)**

- 1) This code has been prepared having considered the provisions of Water Resources Act 2049. It contains general guidelines for water supply installations, sewage/ waste water disposal installations and rainwater disposal installations in buildings.
- 2) The objectives are to make adequate water supply available (without any interruption) for the purpose of drinking, bathing, flushing toilets and any domestic use including firefighting; to provide a system of self-cleansing conditions for conveyance of foul waste water and for the removal of such waste water/sewage to a sewer or outer outlet without risk of nuisance and hazard to health and to dispose rainwater in buildings.
- 3) Due to the limited technical manpower in the country's construction industry, the code has been simplified for the ease of use and implementation. It is hoped that with the development of the manpower and modernization of construction processes, it will be possible to release more sophisticated set of sanitary installation guidelines in future.

## **19. NBC 201: Mandatory Rules of Thumb: Reinforced Concrete Building with Masonry Infill**

- 1) For the last 15 to 20 years there has been a proliferation of reinforced concrete (RC) framed buildings constructed in the urban and semi-urban areas of Nepal. Most of these buildings have been built on the advice of mid-level technicians and masons without any professional structural design input. These buildings have been found to be significantly vulnerable to a level of earthquake shaking that has been happening in Nepal.
- 2) Hence, these buildings, even though built with modern materials, could be a major cause of loss of life in future earthquakes. Upgrading the structural quality of future buildings of this type is essential in order to minimize the possible loss of life due to their structural failure.
- 3) The main objective of these Mandatory Rules of Thumb (MRT) is to provide ready to- use dimensions and details for various structural and non-structural elements for up to three-storey reinforced concrete (RC), framed, ordinary residential buildings commonly being built by owner-builders in Nepal using brick infill walls.
- 4) The practice of using such walls is predominant, but they are treated as non-structural (and hence not accounted for) in the design of the frames. However, when such buildings have horizontal forces imposed on them (e.g., from an earthquake), these infill walls cause the building to respond in an unpredictable manner which has not been considered by the designer. This is due to their contribution to overturning, soft-storey effects, short-column effects, etc. The infill walls could also contribute passively by sharing some of the lateral loads. However, it is anticipated that the present practice of placing such walls randomly will have more negative consequences than positive ones.
- 5) Hence, the objective of this MRT is to ensure the proper placement of such walls in order to derive positive effects only and to achieve economy. Compliance with the MRT will lead to the present non-engineered construction being superseded by pre-engineered designs which should achieve acceptable minimum seismic safety requirements (such as those specified by NBC 105 and IS 1893-1884 etc.). This MRT is intended to cater primarily to the requirements of mid-level technicians (overseers and draughts persons) who are not trained to undertake independently the structural design of buildings. However, civil engineers could also use this document for effective utilization of their time by using the design procedures outlined here.

## **20. NBC 202: Guidelines on Load Bearing Masonry**

- 1) Most of the loss of life in past earthquakes in Nepal has occurred due to the collapse of buildings constructed in traditional materials such as brick, stone, wood, mud and adobe and which were not specifically engineered (not designed for structural safety) to be earthquake-resistant. Thus, it is very necessary to introduce earthquake resistant features in to non-engineered buildings during their construction.

- 2) The objective of this Guideline is to achieve inappropriate level of earthquake resistance in non-Engineered load bearing masonry buildings constructed in Nepal. Following this Guideline does not render masonry buildings able to totally withstand any earthquake without any appreciable damage. However, it is intended to limit the damage to a level which does not threaten human lives and which can be repaired quickly.
- 3) This document includes suitable illustrations to explain the important points, sketches and sufficient data to proportion the critical strength elements correctly. The requirements are based on design calculations of typical structures.
- 4) This document is intended to provide necessary guidelines to owners, builders and masons when a masonry building is to be constructed without engaging professional engineers. However, professional designers could also use this guideline for an effective utilisation of their time.

## **21. Nepal National Building Code, Draft Final NBC 205: 2012 Ready to Use Detailing Reinforced Concrete Buildings without Masonry Infill**

- 1) The main objective of these Ready to Use Detailing (RUD) is to provide ready-to-use dimensions and details for various structural and non-structural elements for up to three-storey reinforced concrete (RC), framed, ordinary residential buildings commonly being built by owner-builders in Nepal.
- 2) Their purpose is to replace the non-engineered construction presently adopted with pre-engineered construction so as to achieve the minimum seismic safety requirements specified by NBC 105 This RUD is intended to cater primarily to the requirements of mid-level technicians (overseers and draughts persons) who are not trained to undertake independently the structural design of buildings.

## **22. NBC 203: Guidelines for Earthquake Resistance Building Construction: Low Strength Masonry**

- 1) A number of documents for better seismic-resistant constructions have been prepared under the National Building Code Development Project (NEP/88/054/21.03) in 1993. Guidelines for Earthquake Resistant Building Construction: Low Strength Masonry (LSM) is one of them. Originally prepared document has been revised by DUDBC in July 2014. This document provides basic guidelines for the earthquake resistance of low- strength masonry construction.
- 2) This guideline is prepared in order to raise the seismic safety of low-strength masonry buildings. This is intended to be implemented by the owner/builder with some assistance from the technicians. This could also act as a basic guideline for architectural design and construction detailing of Low Strength Masonry (LSM) buildings.
- 3) The devastating earthquakes in the past have proved the vulnerability of most of the vernacular buildings of Nepal. Enormous life and property were lost due to the collapse of buildings which

LSM as the main load-bearing element. Earthquakes can neither be prevented nor predicted precisely. But the large-scale destruction can be minimized by employing seismic-resistant measures in buildings. This can be achieved by the use of existing building materials in appropriate ways. This Guideline for Earthquake-Resistant Building Construction: Low Strength Masonry provides the improved techniques that can raise the level of seismic safety of low strength masonry buildings.

- 4) The recommendations provided in this standard shall be mandatory for all types of LSM residential buildings to be built throughout Nepal. Other occupancy types of LSM buildings shall be designed by competent professional engineers.

### **23. NBC 204: Guidelines for Earthquake Resistance Building Construction: Earthen Buildings (Eb)**

- 1) A number of documents for better seismic-resistant construction have been prepared under the National Building Code Development Project (NEP/88/054/21.03) in 1993. Guidelines for Earthquake Resistant Building Construction: Earthen Buildings (EB) is one of them. Originally prepared document has been revised by DUDBC in March 2014. This document provides basic guidelines for the earthquake resistance of earthen buildings in particular.

This guideline is prepared in order to raise the seismic safety of earthen buildings. This is intended to be implemented by the owner/builder with some assistance from technicians. This could also act as a basic guideline for architectural design and construction detailing of Earthen Buildings (EB). The devastating earthquakes in the past have proved the vulnerability of most of the vernacular buildings of Nepal. Enormous life and property were lost due to the collapse of buildings which employed mud walls as their main load-bearing elements. Earthquakes can neither be prevented nor predicted precisely. But the large-scale destruction can be minimized by employing seismic-resistant measures in buildings. This can be achieved by the use of existing building materials in appropriate ways.

- 2) This Guideline for Earthquake-Resistant Building Construction: Earthen Buildings provides the improved techniques that can raise the level of seismic safety of earthen buildings. The recommendations provided in this standard shall be mandatory for all types of LSM residential buildings to be built throughout Nepal. Other occupancy types of LSM buildings shall be designed by competent professional engineers.



## 2.4 Legal Provision and Act for the regulation of Building Constructions

### 2.4.1 Structural Provision

#### 1. Introduction

- 1) The Building Act 2055 BS (Nepali year) has been already published in Gadget in 1998 and come to enforcement in 2005 (BS 2062) in all urban and rural municipalities of Nepal. The building act had been revised in 2007 (BS 2064) with meaningful amendments empowering local level institutions that includes urban and rural municipalities for building code implementations and building regulations.
- 2) In the building act, provision has been made to form **Building Construction Management Upgrading** Committee by the Nepal Government for upgrading and improving building construction system in the country. The structure of the committee is as follows:

i. Secretary, Ministry of Urban Development	Chairman
ii. Representative, National Planning Commission	Member
iii. Representative, Law, Justice and Parliamentary Management Ministry	Member
iv. Joint Secretary, Ministry of Federal Affairs and General Administration	Member
v. Member secretary, Nepal Standards Council	Member
vi. Dean, Institute of engineering	Member
vii. Chairman, Nepal Engineering Council	Member
viii. Three Experts on Building construction, nominated by GoN	Member
ix. Director General, DUDBC	Member Secretary

- 3) The major duty, responsibilities and rights of the committee are as follows:
  - i. To regulate the building construction works so as to minimize the risk of damage on buildings by earthquake, fire and other natural hazards.
  - ii. To prepare building codes for systematizing building construction works and submit the draft to the Government for final approval
  - iii. To carry study and research for timely upgrading of National Building code and to develop new system and technology on building construction
  - iv. Make recommendations to Nepal Standard Council for standardizing the quality of Building materials produced in foreign countries
  - v. Organize meeting/ workshops with technical experts/ professionals/ government staffs from related institutions on issues and challenges on building code implementation for timely improvement.
  - vi. Disseminate information on importance and usefulness of National Building Code to the public by various means.

**The committee has authority to form different sub-committees comprising of related experts and professionals when necessary for carrying out specific jobs.**



## 2. Legal provisions of Building Code

- 1) NBC went into force when the Building Construction System Improvement Committee (established by the Building Act 1998) authorized the Ministry of Physical Planning and Works (MPPW) to implement the code. MPPW published a notice in the Gazette in 2006 and the implementation of NBC became mandatory in all Municipalities and some Village Development Committees (VDCs) in Nepal.
- 2) In 2002, prior to the formal entry into force of the code, Lalitpur Sub-Metropolitan City (LSMC) initiated the implementation of NBC, becoming the first Municipality in Nepal to implement the code. Kathmandu Metropolitan City followed in 2006 and Dharan Municipality in 2007. Other municipalities gradually took similar steps to implement NBC in subsequent years.

### Legal arrangement summary matrix



Legal mechanism	Responsible Institutes	Envisaged role
<b>Building Act 1998 (Rev. 2007)</b>	Building Construction System Improvement Committee	Devise Building Code, facilitate enforcement, disseminate code, monitor implementation, revise code
	MoUD	Approve the Building Code
		Publish notice of mandatory implementation of Building Code
	DUDBC	Implement Building Code in areas outside of Municipal jurisdiction
		Supervise compliance with Building Code
Municipalities	Ensure compliance with Building Code	
<b>Local Government Operation Act 2017</b>	Municipalities	Building permit (includes provision of Building Code)
	House owners in municipal areas	Comply with municipal rules and secure formal building permit before construction
<b>National Building Code – 2003</b>	All concerned	Approved NBC
<b>Notice of MPPW in Nepal Gazette (Feb. 13, 2006)</b>	58 Municipalities, 28 District Headquarters, 81 VDCs	Implementation of Building Act



## 2.4.2 Category of Nepal National Building Code

### 1. Introduction

- 1) Nepal National Building Code has 23 parts. The first part NBC 000 is “Requirements for State-of-the Art Design: An Introduction”, which lays out general provisions of the individual building codes.
- 2) NBC 000 categorizes design and construction of buildings into four types according to their level of sophistication.
  - International state-of-the-art
  - Professionally engineered structures
  - Buildings of restricted size designed to simple Rules-of-Thumb
  - Remote rural buildings where control is impractical
- 3) The major thrust of the code is aimed at the typical and most common buildings currently being constructed in Nepal. It does not suggest as being practical for everyday consideration the sophisticated design philosophies and analytical techniques that appear in the building codes of developed countries. Under the first category International State-of-the-Art, if consultants ensure that their designs meet the corresponding international standard, the designs are considered to be in conformity with NBC.
- 4) The second level refers to Professionally engineered structures and covers all usual structures such as hospitals, meetings halls, factories, warehouses, multi-storey buildings, and residential buildings.
- 5) The third category refers to buildings of restricted size designed with simple Rules-of-Thumb, and mostly applies to remote areas where simpler buildings are prominent. The explanatory documents are such that an experienced Sub-Engineer will be able to understand them and present sufficient details at the time of permit application to prove to a skilled appraiser at the Local Authority that the requirements have been met. The requirements are in terms of limits on spans and heights, minimum reinforcing and member sizes, positioning of earthquake-resisting elements and other such rules.
- 6) The fourth category is guidelines for remote rural buildings. These guidelines address about a dozen typical building styles that have been condensed from an inventory of approximately fifty-five building types surveyed in 1993. In the form of diagrams and descriptions aimed at technical advisors, house owners and lay-men, these guidelines emphasize those changes that should be made to current practices to improve the seismic resistance of these buildings not subject to modern quantitative analysis and rational design consideration. These structures are normally of earthen construction (e.g. unburned masonry, mud-mortar, rubble, dry stone, wattle and daub). Whereas these recommendations are described as guidelines, it is intended to be mandatory for such structures built in areas controlled by a building permit-issuing local authority.

## 2. Classification of NBC according to their use

SN	Type of Building Code	Purpose																		
1	International State-of-Art Applicable codes: NBC 000	<p>Applicable to large building structures. The structures must comply with existing international state-of-the-art building codes.</p>  <p>For Example: Constitutional Assembly Building at Baneshwor, Kathmandu</p>																		
2	Professionally Engineered Buildings Applicable codes: <table border="1" data-bbox="229 1124 632 1639"> <tbody> <tr> <td>NBC 101</td> <td>NBC 107</td> <td>NBC 113</td> </tr> <tr> <td>NBC 102</td> <td>NBC 108</td> <td>NBC 114</td> </tr> <tr> <td>NBC 103</td> <td>NBC 109</td> <td>NBC 206</td> </tr> <tr> <td>NBC 104</td> <td>NBC 110</td> <td>NBC 207</td> </tr> <tr> <td>NBC 105</td> <td>NBC 111</td> <td>NBC 208</td> </tr> <tr> <td>NBC 106</td> <td>NBC 112</td> <td></td> </tr> </tbody> </table>	NBC 101	NBC 107	NBC 113	NBC 102	NBC 108	NBC 114	NBC 103	NBC 109	NBC 206	NBC 104	NBC 110	NBC 207	NBC 105	NBC 111	NBC 208	NBC 106	NBC 112		<p>Buildings designed and constructed under supervision of engineers, buildings with plinth area more than 1,000 sq. ft., buildings having more than 3 stories, buildings with span more than 4.5 m and buildings with irregular shapes</p>  <p>For Example: Multi-Storied Commercial Buildings</p>
NBC 101	NBC 107	NBC 113																		
NBC 102	NBC 108	NBC 114																		
NBC 103	NBC 109	NBC 206																		
NBC 104	NBC 110	NBC 207																		
NBC 105	NBC 111	NBC 208																		
NBC 106	NBC 112																			

<p><b>3</b></p>	<p><b>Mandatory Rules of Thumb</b>  <b>Applicable codes: NBC 201, NBC 202, NBC 205</b></p>	<p>Buildings of plinth area less than 1,000 sq. ft., less than 3 stories, buildings having span less than 4.5 m and regular buildings designed and constructed by technicians in the areas where professional engineers' service is not available</p>  <p>For Example: Three Storied RCC framed Structured Residential Buildings</p>
<p><b>4</b></p>	<p><b>Guidelines of Remote Rural Buildings (Low Strength Masonry/ Earthen Buildings)</b></p>	<p>Buildings constructed by local masons in remote areas and not more than 2 stories</p>  <p>For Example Brick or Stone in mud mortar Rural Building with slate/CGI Sheet roofing</p>

### 2..4.3 Strategy for Building Code implementation

#### 1. Introduction

- 1) The experience of building code implementation in Nepal demonstrates that legal mechanism alone is not sufficient for effective implementation of Building Code. Although the legal provision makes all urban and rural municipalities responsible to implement the code, it has achieved limited success. One of the decisive factors in effective implementation of NBC is capacity of the municipalities. Another equally important aspect is political will of the municipal authorities to start the process. Awareness on earthquake safety among municipal authorities and general public can create conducive environment for making a political decision to implement NBC.
- 2) Mode and stages of implementation are different in different municipalities. Many factors such as construction typology and the availability of human and financial resources determine the building code implementation strategy. However, the basic components for effective implementation of NBC are similar for all types of municipalities. The key components are summarized in the following figure and descriptions:

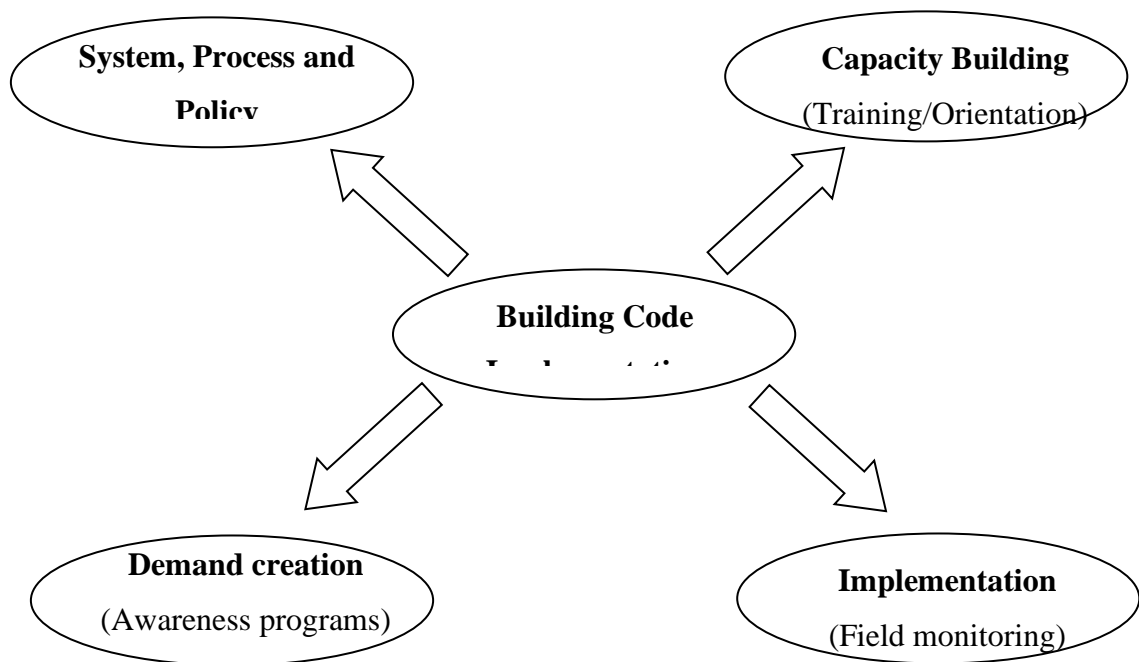

## **2. Establishment of new process: Introduce new permit system, process and policies:**

- 1) Implementation of building code requires a well-documented and systematic process. In order to ensure smooth implementation of NBC, it is necessary to establish a realistic process. Municipalities with large numbers of building constructions may have to have a separate technical section for building code implementation whereas municipalities with few numbers of building construction may continue with the same section/unit with or without additional staff. One of the salient features of NBC is its recognition of Mandatory Rules of Thumb (MRT) which simplifies the implementation process significantly in municipalities where large building construction is rare. Therefore, municipalities can start in the first stage with implementation of MRT. The process should be able to address the requirements of all other three components from capacity building to demand creation.
- 2) The municipalities which have already started the NBC implementation can have following strategy for effective implementation:
  - Update & Modify existing system and process
  - Introduce new Implementation policies
  - Introduce registration system of trained Masons for building construction

## **3. Capacity Building (Training/Orientation/ Capacity Building Programs)**

- 1) Implementation of Building Code should be simultaneously followed by training, orientation and capacity building programs for better results and more compliance. The programs will be as following:
  - Regular Orientation Programs to House Owners on Earthquake Resistant Construction Technology
  - Regular Training programs to local Masons on Earthquake Resistant Construction of Buildings
  - Training Programs to Municipal engineers and designers on national building code and earthquake resistant design of buildings
  - Refresher courses for trained municipal engineers and designers
  - Besides the technical capacity resource and financial capacities are also equally important.





*Figure 5. Mason Training Programs in Lalitpur*

#### **4. Field implementation (Field inspection/ Monitoring)**

- 1) One of the important aspects of building code implementation is its effective implementation in practice. Buildings do not perform the way they are designed, but they perform the way they are constructed in the field. Field inspection is one of the key components to ensure earthquake resistant construction. A simple checklist for field inspection is given in Appendix IV. The checklist can be different for different municipalities depending on their needs.
- 2) The following strategy should be followed for better compliance of NBC in the field.
  - Formulation of Effective Field Inspection Mechanism to control the quality of construction and compliance of building codes in field
  - Mobile Clinic with free counseling service to house owners and masons at construction sites
  - Introduce inspection card system or field monitoring checklist to monitor every stages of building construction

## 5. Demand creation (Awareness programs at community level):

- 1) Aware people not only create demand for safe housing, but also help with monitoring in the field. Therefore, awareness raising should be one of the key components of NBC implementation.
- 2) Without the community support and acceptance building code cannot be implemented effectively. So following activities should be carried out for awareness raise of community people for safer construction practices and better preparedness:
  - More publications on earthquake preparedness and safer construction practices
  - Installation of informative Hoarding Boards for better preparedness
  - PSA in FM Stations for safer construction and earthquake preparedness
  - Mass awareness programs for community people on earthquake risk, preparedness and recovery planning
  - Awareness programs for school teacher and students on earthquake safety



Figure 6. Earthquake Safety Day & Awareness Program in Lalitpur



## Role of Building code in reducing earthquake risks in Nepal.

Building codes play a crucial role in reducing earthquake risks in Nepal. Given Nepal's geographical location and its vulnerability to seismic activity, the implementation and enforcement of effective building codes are essential for mitigating the potential damage caused by earthquakes. Here are some key ways in which building codes contribute to reducing earthquake risks:

**Structural Integrity:** Building codes provide guidelines for the design and construction of structures that can withstand the forces generated by earthquakes. They specify minimum requirements for structural elements, such as foundations, columns, beams, and walls, ensuring their strength, stability, and resistance to lateral loads.

**Seismic Design Parameters:** Building codes establish seismic design parameters that take into account the specific seismic hazard levels of different regions in Nepal. These parameters consider factors such as peak ground acceleration, spectral response, and soil characteristics, helping engineers and architects design structures that can withstand potential ground shaking.

**Material Standards:** Building codes set standards for the quality and suitability of construction materials, such as concrete, steel, and masonry. These standards ensure that materials used in building construction possess the necessary strength and durability to resist seismic forces.

**Reinforcement Techniques:** Building codes provide guidelines for the use of reinforcement techniques, such as steel reinforcement bars, shear walls, and moment-resisting frames. These techniques enhance the ductility and energy dissipation capacity of structures, enabling them to absorb and dissipate seismic energy during an earthquake.

**Non-structural Elements:** Building codes also address the stability and safety of non-structural elements, such as partitions, ceilings, facades, and utilities. Proper installation and bracing of these elements help prevent their collapse during an earthquake, reducing the risk of injuries or blockage of evacuation routes.

**Inspection and Enforcement:** Building codes require regular inspections during construction to ensure compliance with the specified design and construction standards. Adequate enforcement of building codes through inspections, certifications, and permits helps ensure that buildings meet the required seismic resistance criteria.

By incorporating these measures, building codes aim to enhance the seismic resilience of structures and minimize the potential loss of life and property during earthquakes. However, it is essential to continuously update and improve building codes based on the latest research, technology, and lessons learned from seismic events to further reduce earthquake risks.

## Initiations for successfully implementation of Building Code

The implementation of building codes has been an ongoing effort to improve seismic resilience. While the enforcement and compliance process is still evolving, there have been notable examples of successful implementation. Here are a few examples:

**Post-Earthquake Reconstructions:** Following the devastating earthquakes in 2015, The Government of Nepal implemented a series of measures to improve building safety. The National Reconstruction Authority (NRA) led the reconstruction efforts, emphasizing the implementation of improved building codes. The newly constructed buildings, particularly in the affected areas, were designed and constructed in accordance with updated seismic design standards and guidelines.

**Government Initiatives:** The Government of Nepal has taken initiatives to enhance the implementation of building codes. The Department of Urban Development and Building Construction (DUDBC) and the Department of Roads (DoR) have been actively involved in promoting and enforcing building codes across the country. They conduct inspections, issue construction permits, and enforce compliance with the prescribed standards.

**Capacity Building Programs:** Several organizations and institutions in Nepal have conducted capacity-building programs to educate engineers, architects, contractors, and other stakeholders about the importance of building codes and seismic design principles. These programs aim to enhance the understanding of seismic risks and proper implementation of building codes in construction practices.

**Awareness Campaigns:** Awareness campaigns have been carried out to inform the general public about the significance of building codes in reducing earthquake risks. These campaigns highlight the importance of constructing and retrofitting buildings to meet the required seismic standards.

**Institutional Collaboration:** Collaboration between government bodies, non-governmental organizations (NGOs), and international agencies has played a crucial role in the successful implementation of building codes in Nepal. These collaborations bring together expertise, resources, and technical assistance to support the development and enforcement of building codes.

It's important to note that the implementation of building codes is an ongoing process in Nepal, and there is still work to be done to ensure widespread compliance and enforcement. Continuous efforts in capacity building, public awareness, and collaboration among stakeholders are essential for the successful implementation and impact of building codes in reducing earthquake risks in Nepal.

## Implementation of Building Code by Municipalities

The Nepal Building Code (NBC) has been successfully implemented by municipalities in a number of ways. Here are some examples:

**Establishment of building control units:** Many municipalities have established building control units (BCUs) to oversee the implementation of the NBC. These units are responsible for issuing building permits, inspecting construction sites, and enforcing the code.

**Training of municipal staff:** Many municipalities have trained their staff on the NBC. This training has helped to ensure that municipal staff are familiar with the code and its requirements.

**Public awareness campaigns:** Many municipalities have conducted public awareness campaigns to raise awareness of the NBC. These campaigns have helped to inform the public about the importance of building safety and the requirements of the code.

**Enforcement of the code:** Many municipalities have taken steps to enforce the NBC. This includes issuing fines for violations of the code and demolishing buildings that do not comply with the code.

The following are some specific examples of how municipalities have successfully implemented the NBC:

- Lalitpur Metropolitan City was the first municipality to implement the NBC. The city has a well-functioning BCU that is responsible for issuing building permits, inspecting construction sites, and enforcing the code.
- Kathmandu Metropolitan City has also been successful in implementing the NBC. The city has a strong BCU and has conducted a number of public awareness campaigns to raise awareness of the code.
- Damak Municipality in Jhapa district has been a model for other municipalities. The municipality has a strong BCU and has been very successful in enforcing the NBC.

These are just a few examples of how municipalities have successfully implemented the NBC. The code is still a work in progress, but it has already made a significant difference in the safety and quality of construction.

### **Challenges and obstacles the government faces in implementing the NBC in all municipalities**

The implementation of the National Building Code (NBC) in all municipalities faces several challenges and obstacles. Some of the key challenges include:

- **Limited Awareness and Capacity:** One major hurdle is the limited awareness and understanding of the NBC among professionals, local authorities, and the general public. Many stakeholders may not be fully aware of the code's provisions, requirements, and importance. This lack of awareness can hinder the effective implementation and enforcement of the NBC.
- **Enforcement and Compliance:** Ensuring consistent enforcement and compliance with the NBC across all municipalities is a significant challenge. Municipalities may face resource constraints, including a shortage of trained personnel, technical expertise, and financial resources required for effective enforcement. Insufficient monitoring and inspection systems can lead to non-compliance with the NBC's standards.
- **Technical Expertise and Training:** Adequate technical expertise is crucial for implementing the NBC effectively. However, there may be a shortage of qualified professionals, such as architects, engineers, and building inspectors, who are well-versed in the provisions of the NBC. Limited

training opportunities and professional development programs can hinder the capacity building needed for successful implementation.

- **Informal Construction Practices:** Informal construction practices and the presence of unregulated or unauthorized builders pose a significant challenge to the implementation of the NBC. In many cases, informal construction occurs outside the purview of the regulatory authorities, making it difficult to ensure compliance with the code's provisions.
- **Local Context and Cultural Factors:** Nepal's diverse geographical and cultural contexts can present challenges in implementing a uniform building code. The specific needs and requirements of different regions, such as rural areas or areas with specific architectural traditions, may need to be addressed within the framework of the NBC while ensuring safety standards are not compromised.
- **Coordination and Governance:** Effective coordination and governance between different government bodies, including the central government, municipal authorities, and regulatory agencies, are essential for successful implementation. Ensuring clear roles, responsibilities, and communication channels can be a challenge, particularly when multiple agencies are involved.

Addressing these challenges requires a multi-faceted approach involving awareness campaigns, capacity building initiatives, resource allocation, strengthening enforcement mechanisms, and fostering collaboration among relevant stakeholders. Continuous monitoring, evaluation, and periodic updates of the NBC can also contribute to its effective implementation in all municipalities.

**PART THREE: BASICS OF BUILDING PERMIT SYSTEM IN  
NEPAL**

## 3.1 BUILDING PERMIT SYSTEM IN NEPAL

### 3.1.1 Processes of Building Permission System

#### 1. Stage-wise Building Permit Process

- 1) The building permit process is designed in three stages. First stage starts with application by owner and ends with Temporary Permit for construction up to Plinth Level. In the second stage, the house owner applies for permanent permit and field checking is done jointly by the Building Permit Section/Unit and Building Code Section/Unit. If the construction is in conformity with By-laws and NBC, permanent building permit is issued. Finally, field checking is conducted at different stages of construction and the Completion Certificate is issued to the owner. The process is shown in the following table.
- 2) The detailed building permit process is shown in figure below:

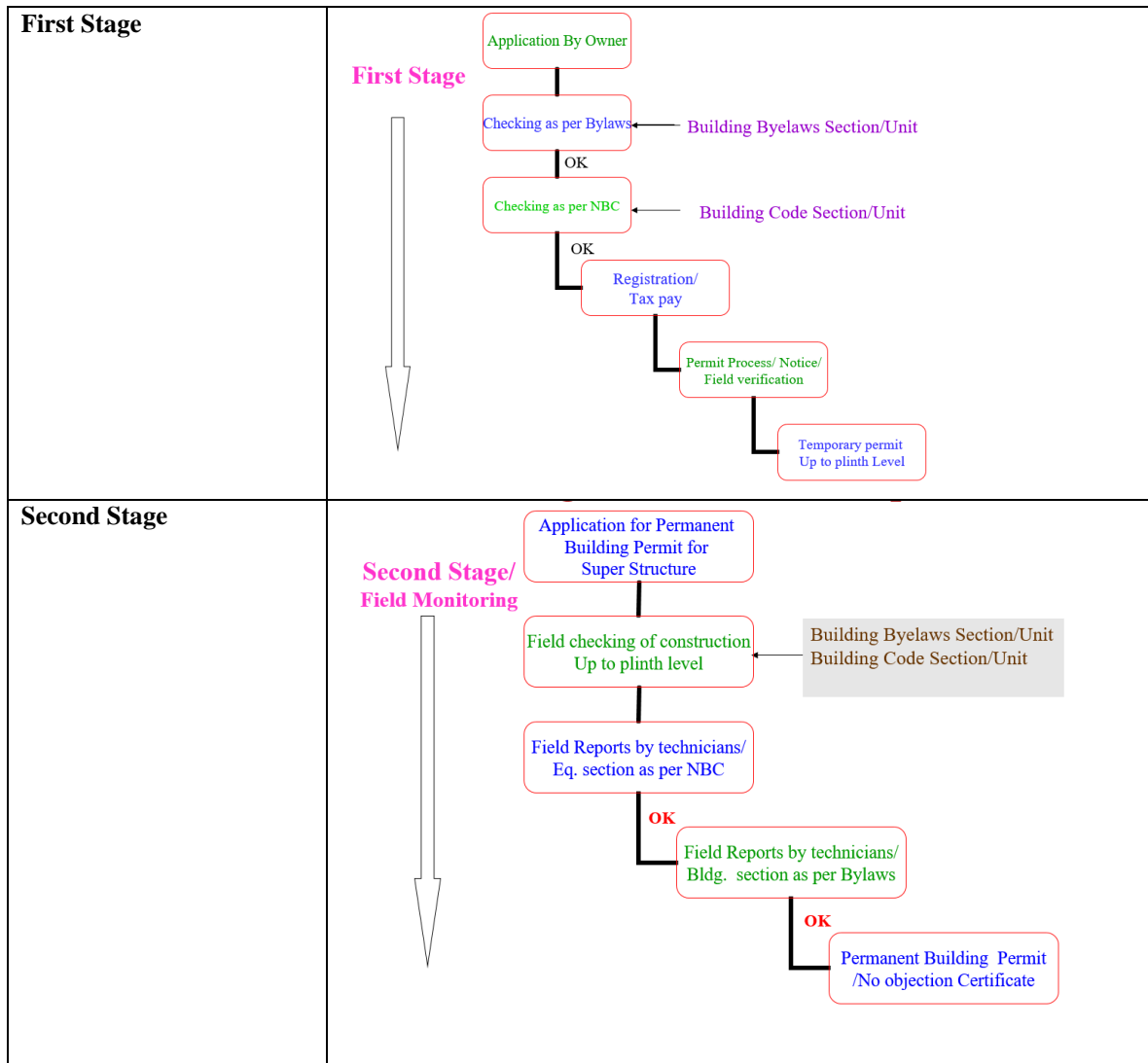

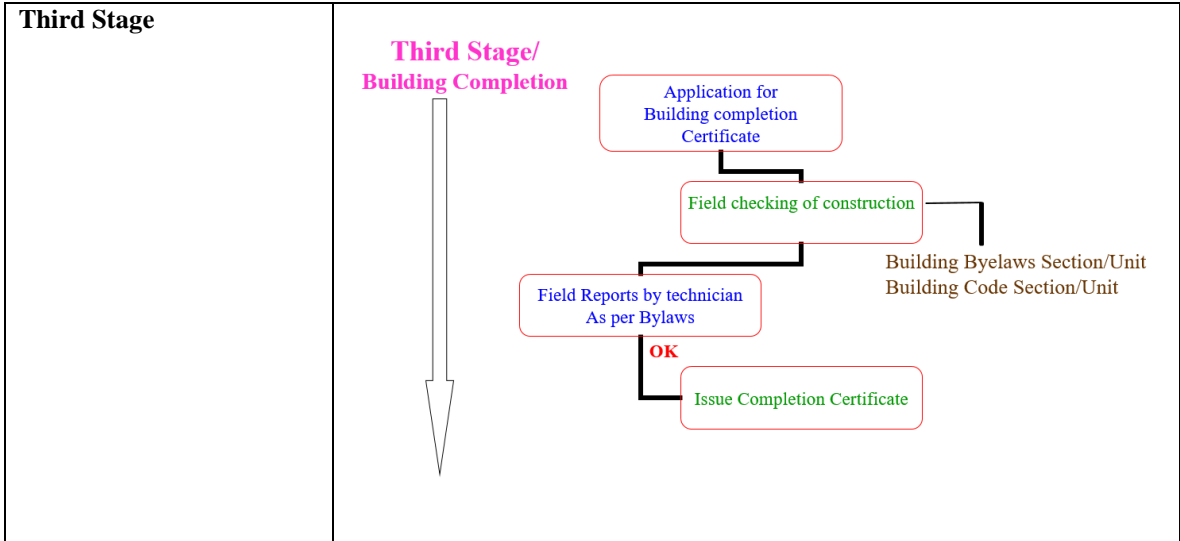

*Three Stages of Building Permit*

## Flow Chart of Building Permit Process

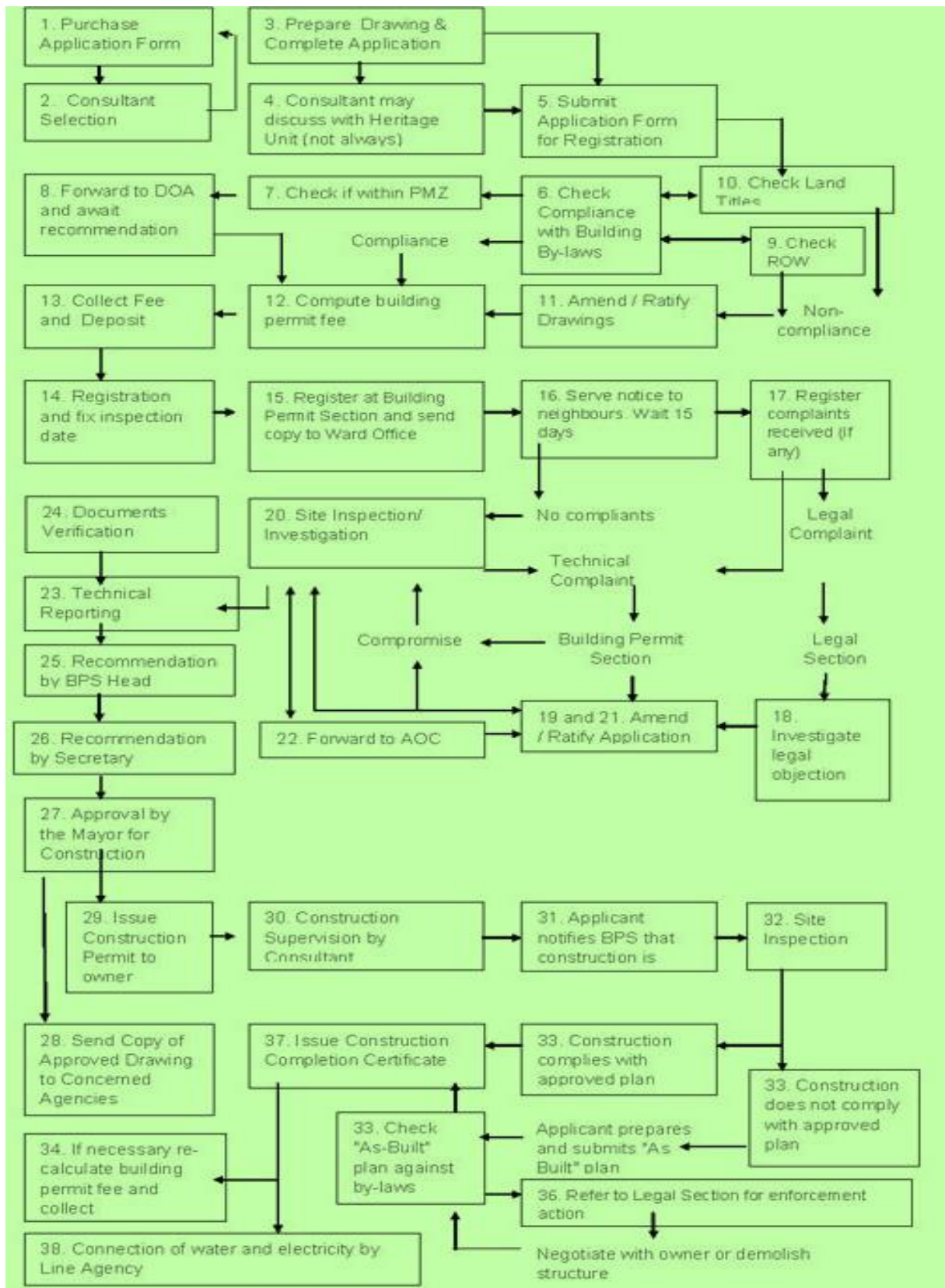



### 3.1.2 Stages of Building Permission System

#### 1. Stage I: Temporary Building Permit up to Plinth Tie Beam Level

##### 1) Step 1: Preparation and submission an Application Documents, Designs and Drawings at Registration Desk

- a) Building owner shall get the designs, drawings & details prepared through the registered designer/consultant in the municipality. The registered designer/consultant shall first submit the designs, drawings, details and all other supporting documents to the Registration Desk of the section or division of the municipality issuing Building Permit. Requirements of the documents, designs, drawings and detailed design report shall be as per the municipality rules.
- b) Application form for the building permit shall include the signatures of the building owner or his/her authorized representative and the designer along with the names, addresses and contact numbers. The designer shall clearly mention his/her registration number in the municipality or Nepal Engineering Council number which is applicable in the application form.

##### 2) Step 2: Approval of Submitted Designs, Drawings & Details

- a) **Documents Check:** Municipality shall check that the application form complies with the requirement and includes all required documents. In case any details or documents are incomplete or missing, municipality shall request the building owner and the designer to complete or submit the same.
- b) **Building By-laws Check:** Submitted drawings will be checked by the Municipal surveyor on aspects related to the access road, land plot and GLD Planning, if any. If there are no issues related to the access road, land plot and GLD Planning, engineer from the building By-laws section/unit shall carry out checks related to the compliance of prevailing building By-laws and then forward the designs and drawings to the building code section.
- c) **Building Code check:** Engineer from the Building code section/unit shall check the submitted designs and drawings for the compliance of building code and if no related issues are there, the submitted application for building permit along with the designs & drawings shall be forwarded to the authorized person for municipal registration.
- d) **Verification of design drawings:** In case the submitted designs and drawings are non-compliant with respect to the building By-laws and/or building code, the application along with the designs and drawings shall be returned to the applicant. The applicant shall carry out all necessary corrections and modifications as suggested by the building By-laws and building code sections and then resubmit the application with necessary designs and drawings to the application desk. Thereafter, necessary checking will be carried out and finally registration will be carried out.
- e) **Registration of Building Application:** The Chief Administrative Officer or the authorised person to issue the building permit shall endorse the application along with all supporting documents after due checking by the technical section and then forward the same to the registration section.

### 3) Step 3: Field Verification and Complaint Filing by the Ward Office:

- a) The submitted application form with designs & drawing from the **Registration Desk** shall be sent to the ward office through the staff of the office or the building owner or his/her immediate family member or his/her authorized representative. The process of field verification & complaint filing is done as mentioned below.
- b) **Public Inquiry “Sarjamin”:** 15 days’ notice is sent to the landowners of the land parcels abutting to the land parcel to file any complaint application in case there are issues on boundary of property line, side setbacks, land area and other legal/technical/practical issues. In case no complaint is registered, municipality shall depute a technician and a admin person to conduct public inquiry and field investigation of the building application. The municipality staffs shall conduct a field verification work and carry out investigation in regard to the complaint received, if any. Such field verification or *Sarjamin* shall be conducted in presence of the landowner of the proposed building filing the building permit, land owners of the land parcels abutting to the land parcel of the applicant, neighbours and a ward representative. The municipal staff shall prepare a deed of public inquiry (Sarajmin Muchulka) recording grievances, if any, received at the time of public inquiry.
- c) **Field Report Submission:** The municipal technician shall submit a field report office along with the minutes of the public inquiry with recommendation for issuing building permit to the applicant. In case any changes are required in the submitted designs and drawings due to the discrepancies in field conditions with compare to the submitted designs and drawings, the technician shall also mention the same in the field report. In such cases, the Building Owner shall submit revised designs and drawings with the help of the designer consultant. The Technical shall re-verify such revised designs and drawings for compliance check against building By-laws and building code.
- d) **Complaint Processing:** In case complaints are received from one or more landowners of the land parcels abutting the land parcel of the applicant, ward office shall submit the application file along with the complaints received to the Building By-laws Section/Unit. Building permit issuance shall be kept on hold till the matter of the complaint is fully resolved. If the municipality decides to issue building permit after the processing of the complaint, processing of the application file will move ahead.
- e) **File Submission by the Ward Office after Field Verification:** Ward office shall forward the application file along with the field report and minutes of public auditing to the building permit division/section of the municipality through the staff of the ward or the Building Owner or his/her authorised representative.

#### 4) Step 4: Payment of Building Permit Fee

- a) **Recommendation to the Revenue Desk:** After receiving the application file from the ward office with clear recommendation for the issue of building permit in the field report, Technical Section shall forward the application file to the **Revenue Section** for the payment of the building permit fee as per prevailing financial act and regulations of the municipality.
- b) **Payment of Building Permit Fee:** The Building Owner shall make payment for the prescribed building permit fees by depositing the fee in the Revenue Section of the municipality. After the payment of the fee, the Revenue Section shall forward the file to the Building By-laws Section/Unit

#### 5) Step 5: Temporary Building Permit for the Construction up to Plinth Level

- a) **Design Approval & Temporary Building Permit:** The building owner then needs to submit a copy of the receipt or voucher of the payment of building permit fee to the Building Byelaws Section/Unit. Then the application is forwarded to the authorised officer with recommendation to issue building permit.
- b) The applicant shall then be issued temporary building permit along with a set of approved drawings.

## 2. STAGE II: PERMANENT BUILDING PERMIT FOR CONSTRUCTION OF SUPERSTRUCTURE

#### 1) Step 6: Construction up to the Plinth level

- a) **Commencement of the Building Construction Works:** After getting temporary building permit, the building owner shall carry out construction up to the plinth level of the building as per the approved drawings.
- b) **Technical Report by the designer/ consultant:** Registered designer/consultant shall supervise the building site and prepare the technical report which prove that the building is constructed according to approved drawings along with photographs of the field progress.

#### 2) Step 7: Inspection at Plinth Tie Beam Level:

- b) **Inspection up to the Plinth Level:** After receiving the application for plinth level site inspection, the technician deputed from the municipality shall carry out site inspection and verify that the actual construction has been done as per the approved designs & drawings up to the plinth level. The technician shall recommend for the issuance of Permanent Building Permit. The Building By-laws Section/Unit of the municipality shall recommend to the Chief Administrative Officer for issuing Permanent Building Permit Certificate if the actual construction has been done up to the plinth level.

### 3) Step 8: Permission for the Construction of Superstructure

- a) After receiving the technical Report from the Building By-laws Section/Unit for the issuance of Permanent Building permit, the Chief Administrative Officer shall review the technical report submitted by the technician and if it is found that everything is in order, then CAO shall issue the Permanent Building Permit for the construction of superstructure of the building.

## 3. Stage III: Final Building Completion Certificate

### 4) Step 9: Construction of Superstructure of the Building

- a) **Commencement of the Superstructure Construction:** After getting permanent building permit, the building owner shall carry out construction of the superstructure as per the approved drawings.
- b) **Technical Report by Designer/ Consultant:** Designer/ Consultant shall supervise the building site and prepare the technical report to assure that the building is constructed according to approved drawings along with photographs of the field progress.

### 5) Step 10: Building Completion Certificate

- a) **Final Inspection by Municipality:** After receiving the application for the final inspection, the technician deputed from the municipality shall carry out final inspection of the building, review its supervision report and verify that the actual construction has been done as per the approved designs and drawings. The Technician shall then submit the final inspection report to the Building By-laws Section/Unit with recommendation for the issue of a completion certificate if the actual construction has been done as per the approved design, drawings.
- b) **Issuance of Building Construction Completion Certificate:** If the building has been completed as indicated in the technical report and the building has been painted at least one coat on the inside and outside surfaces and maintenance of public infrastructure road, drain etc. have been completed, then the building construction completion certificate shall be issued to the applicant by the Municipality.

**The require documents for processing building permission in municipalities has been tabulated in Annex III.**

**PART FOUR: INDIGENOUS KNOWLEDGE AND  
TECHNOLOGIES FOR SAFER BUILDINGS**

## 4.1 Historical Background of Indigenous Knowledge and Technologies

### 4.1.1 General Introduction

#### 1. Introduction:

- 1) Nepal is a landlocked country, bordered by the Tibet region of China on the north and India on the south, east, and west. Situated on the lap of the high Himalayas, Nepal has a unique geographical profile: the country rises from 65 m above sea level to more than 8,000 m., resulting in a highly versatile landscape with six different climate zones within the country's average width of 193 km. Nepal is broadly divided into three ecological belts: Mountains, Hills and Terai plain separated by three mountain ranges, Chure, Mahabharat and Himalayas.

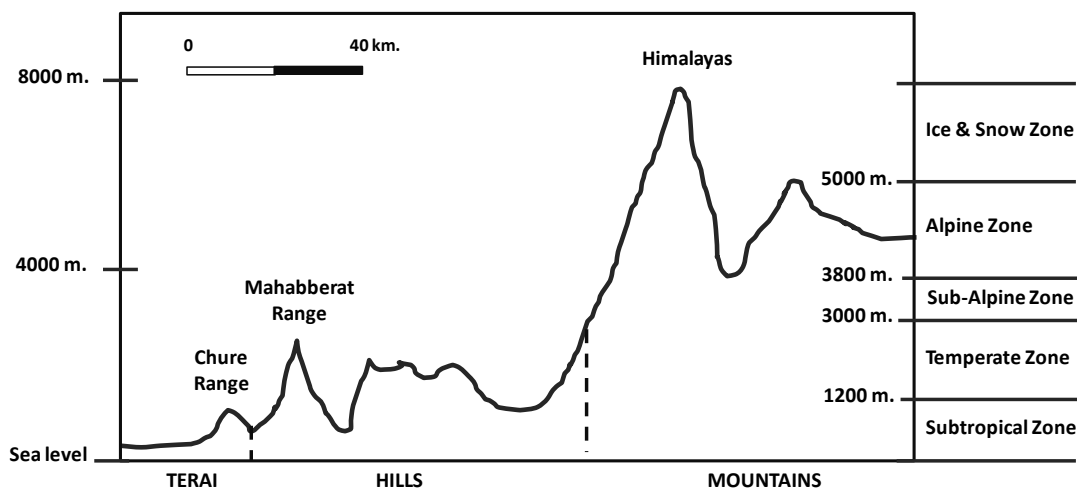

**Figure 1. Nepal's geological profile**

Source UNDP/ERRRP: Indigenous Knowledge and Technologies for Safer Buildings

- 2) Nepal's history can be traced back to the 5000-year-old ancient holy books of the Hindus. Indeed, Kathmandu Valley (or Nepa valley in the old Newari language) was a valley of ancient towns as far back as 2nd century AD and it is here that the name Nepal originated from.
- 3) Nepal is a buffer country between China and India having about 800 kilometers long (East to West) and 190 kilometers wide (North to South). It is not only a buffer state between its neighbors, Tibetan Buddhist and mainly Indian Hindus, but also the meeting place of many different races. In the south the Indo-Aryan races are predominant, in the north the Tibetan speaking groups prevail and in the midlands, one finds a mixture of Tibeto-Burman and Indo-Aryan groups.
- 4) The Himalayan regions cover an extremely wide range of ecological milieu from the tropical zones (Terai) of the Indo-Gangetic basin, to the interior valleys, situated at an altitude of over 4000m, with an intermediate zone of highly compartmentalized hills which vary from 600 to 2000meters in altitude. The transition is so rapid that people approaching Nepal from the South

arrives in a hot, flat and humid region, can perceive the snow-clad Himalayan chain in the distance. The numerous kinds of natural milieu subject the inhabitants to adopt different constraints. In some places, one has to fight against the heat and parasites to ensure reasonable living conditions, in others it is a battle against the persistent and penetrating cold of the high mountains.

- 5) From seismic hazard point of view, Nepal lies in the boundary of two active tectonic plates. Nepal is prone to earthquakes due to continuous movement of Indian Plate towards north at three cm per year. Available seismic records show that mega earthquakes have hit Nepal at an interval of approximately 80 years. During the past hundred years, at least four major earthquakes of magnitude greater than 8 on the Richter scale have devastated Nepal. The earthquake of 1934 destroyed 20 percent of the building stock in Kathmandu and damaged another 40 percent. The seismic zoning map of Nepal divides the country into four zones elongated in the northwest–southeast direction; the middle part of the country which happens to be most populated is also most prone to earthquakes.
- 6) It will be convenient to think of Nepal as being divided into three topographic/climatic belts, each one stretching from East to West across the country. From South to North, they are; the tropical Terai, the sub-tropical/temperate hills, and the mountain areas. There is overlap and interpenetration between these areas and finer divisions are justifiable for some purposes.
- 7) Indeed, there is an "inner-Terai" north of the southernmost range of hills, but these three broad divisions will serve to illustrate some major architectural styles. Different parts of the country have been settled by people of diverse cultures. The distinct ways of life followed by these people have combined with climate, topography, and other disaster factors to shape the settlements in which they live. Since the ascendancy of Muslims in northern India in the 12th century, Indo-Aryans have immigrated to Nepal to find protection in the mountains. These pure Hindu groups, mainly Brahmans and Kshetris have spread quite evenly over the whole midland area whereas the Tibeto-Burman tribes have settled and remained in their own areas. History shows that generally the indigenous population was not driven away or unduly suppressed by the arrival of immigrants. A superimposition resulted, placing the immigrants in a somewhat superior or even ruling position, but tribal integrity was kept intact. The reduction of the tribes to a single population group by brutal force or religious power was never attempted. The bonds of tribe and caste are still much stronger than, for example, bonds of religious grouping.
- 8) Different architectural styles and developments took place in different parts of Nepal, the most important, besides the architecture of the Newars, are those of the Sherpas and Thakalis, which were both heavily influenced by Tibet. All the other tribes or castes, such as the Gurungs, Magars, Kshetris, Brahmans and Tharus, for example, developed their own Indigenous architecture, but the technology was not comparable with that of the Newars. Therefore, each style within the country has presented in its own way.
- 9) In this section Indigenous architecture of three divisions that is mountain, hill and Terai has been described in general and detail description has been provided for Indigenous architecture of Kathmandu Valley.

## **2. Definition of Indigenous architecture**

- 1) Indigenous architecture is the architecture which develops through time to meet the specific needs of the society by accommodating the values, economy, and ways of living of the society in which they live. Indigenous architecture is always guided by the local climate, culture, topography and local material and construction technology. Indigenous architecture cannot be credited to a person or an architect, but it is the result of years of practice passed on and improved from generation to generation.

## **3. Indigenous Architecture of Mountain Region**

- 1) The mountainous regions of Nepal are among the harshest environments in the world. Permanent human settlements are found only in those high valleys where the severe climate and terrain are slightly mitigated by permanent sources of water and micro-climatic conditions.
- 2) Fuelwood is scarce in this arid land, and consequently burned bricks are seldom seen. Stone is by far the most common building material, although in some areas large unfired bricks are found and in others, mud is laid up in wooden frames as wide as the thickness of the walls. When the mud has set hard, the frames are slipped up the wall to the next level and another course of mud is laid. This method of construction is possible because of the rapid drying which takes place in this arid windy region.
- 3) Extreme cold and extreme dryness are the limiting factors with which the inhabitants of the Himalayas have worked in developing their own traditional architecture. Its settlements are considered as the earliest human habitation in the whole of Himalayan region lying between Manang in the east and Mustang in the west. It is considered that human settlement in the Mustang Valley dates to 700 to 800 B.C. Sherpa, Manangi, Paancha-gaull. Botia, and Thakali are some of the names by which the ethnic groups of these high mountainous regions are known. To a greater or lesser extent, these people, their architecture and their culture in general have been influenced through the centuries by Tibetan in the North. In some areas, the cold wind from the snow-covered mountains is so severe that houses are partially built into the walls of the mountain. Passages between buildings sometimes cross over the village street at first floor level enabling the inhabitants to avoid going outdoors in the cold. Frequently, animals are housed in the ground floor of house, their body heat is said to rise to the upper floors and assist in keeping the people warm. Ceilings are low, to prevent warm air from rising to a level where its benefit will be lost. Frequently, buildings are situated around a courtyard which is protected from the wind by the building walls.

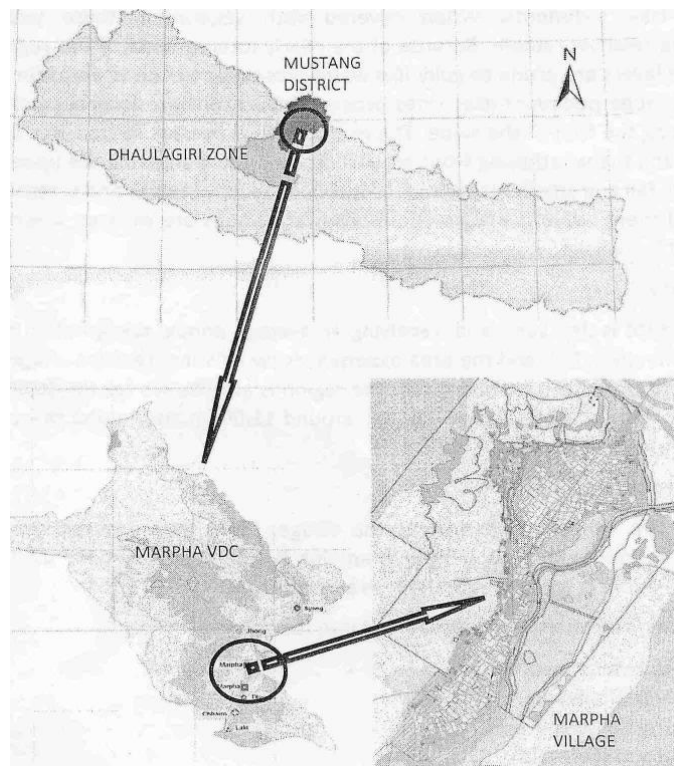



**Figure 2. Traditional Houses of Mustang**

Source UNDP/ERRRP: Indigenous Knowledge and Technologies for Safer Buildings

- 4) Ascending into the rain shadow areas (rain from the south cannot pass beyond the mountain barrier) roofs change from pitched (to shed rain) to flat. These flat roofed buildings typically have thick walls pierced by small windows and doors. The surface of the flat roof functions as a place to work or sit when the sun shines. Here too, fuelwood is also stored and food dried.



**Figure 3. Location Map of Marpha**

Source UNDP/ERRRP: Indigenous Knowledge and Technologies for Safer Buildings

- 5) As typical example of Indigenous architecture of Mountain region, one residential house of Marpha is selected and explained.
- 6) Marpha is situated in Mustang district of Dhaulagiri zone in Western Development Region of Nepal. The geographical location of Marpha village is 28°45' North latitude and 83°42' East longitude. Among the 16 villages of Mustang District, Marpha Village is one of them. This district is surrounded by Manang district in east, Dolpa district in west, Mygadi district in south and Tibetan Plateau in the north. Marpha is connected with Ghasa in the South and Muktinath in the North along the highway. The village of Marpha in the Thak Khola valley have an arid and windy climate. The village is densely built to save arable land, and to provide protection from harsh weather conditions. Marpha is situated at an altitude of 2650 m. on a fluvial terrace along the riverbank of the Kali Gandaki.
- 7) The settlement of Marpha village is small and linear in form and lies along the trek route to Upper Mustang. Due to its climatic condition, it is compact in form. The whole village lies just below a steep cliff at North-West side. To escape from strong wind blowing in North-South direction, the entire village is oriented towards N- E and S-W direction. For the construction of houses, the slopes at N-W direction are omitted and no openings are provided in South and North direction. Marpha's climate is dry, semi-arid, receiving an average annual precipitation of only about 350mm, and the area experiences two distinct seasons of a warm summer and a cold dry winter. The region is also known for the strong winds that begin to whip through the valley every day around 11:00 am. In Marpha these winds reach an average of 10-15m/s. Thakalis are the indigenous people of the village. More than 76% people are Thakalis followed by Bramhins & Kamis.



**Figure 4. View of Marpha Village**

Source UNDP/ERRRP: Indigenous Knowledge and Technologies for Safer Buildings

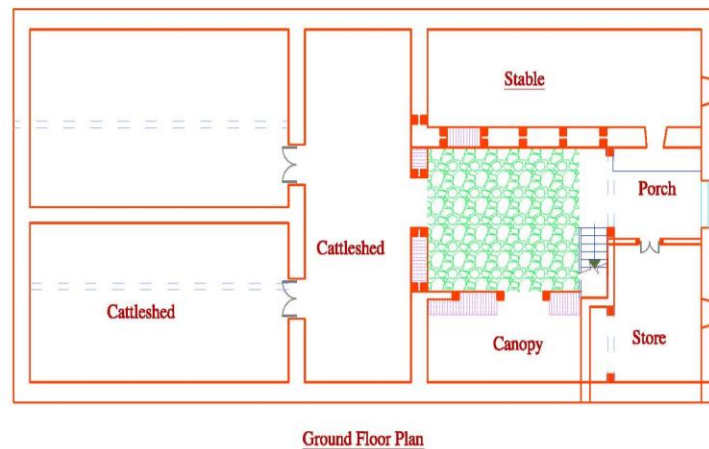
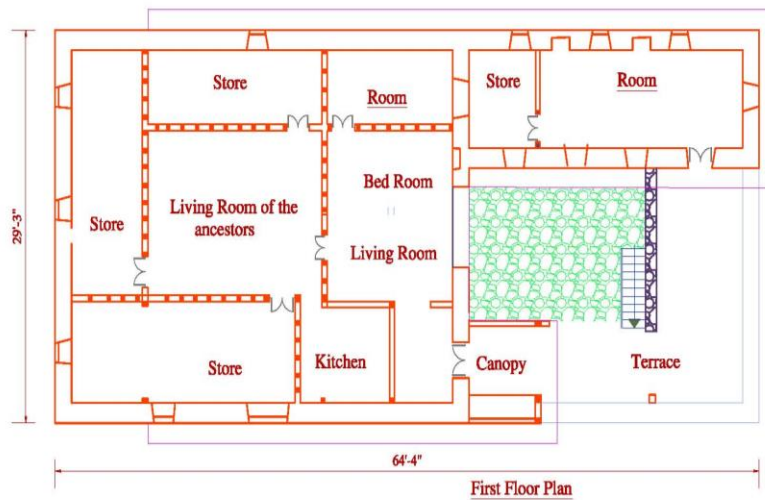

**Figure 5. Plan of Residence in Marpha**

Source UNDP/ERRRP: Indigenous Knowledge and Technologies for Safer Buildings

- 8) The central room, the most important room in the house, is called the ancestors. A fireplace against the back wall, built of stones and coated with red earth, is used during the worship of the ancestors, and on important occasions such as marriages. It is to the right of this fireplace that a woman gives birth. Copper vases containing juniper branches are placed next to it. In the right-hand corner of the room: water pitchers and an earthenware bowl filled with barley are kept.
- 9) The room of the ancestors gives access to three stores. On the right, contains the family wealth: jewels, clothes, fabrics kept in several trunks. On the left, jars used in the making of alcohol, vegetables, fruit, and products imported from the lower valleys (rice, lentils) are kept. Grain

and flour reserves are stored right at the end of the room. In addition, the first floor includes an extra bedroom and a small store where trunks and baskets are kept.

- 10) The staircase provides access to the terrace. A large portion of the terrace is left empty, and without roof, for the thrashing of cereals at the time of the harvest. A canopy, closed on these sides, enables one to store the baskets and tools necessary for threshing. Seasonal laborers can sleep here.

#### 4. Construction Material and Technology

- 1) This house is constructed as load bearing structure as most of the other houses in **Marpha**. The local materials such as stone, timber and mud are used as construction materials. The binding material is mud and lime mortar. The exterior of house is painted white with lime. The white colour is used, as it is their traditional colour and it reflects the colour of the bright snow mountains.
- 2) **Masonry work:** From foundation to plinth level stone with mud mortar is used. The foundation of this house has depth of 60 cm and is raised up to one meter above the ground floor level to control from dampness. Super structure wall is generally built with ghyanga (a wall made with mud mix with gravel). First wooden formwork is prepared & plastic mass of suitable proportion mud/gravel is compacted with wooden hammers manually. This is done in layer by layer (one layer having height not more than 2 feet) & after gaining required ceiling height, roof is constructed. The wall thickness varies on the ground floor and first floor.
- 3) **Framework:** Apart from load bearing wall, other structural parts are constructed of timber. The timbers are used on framework of the floor, opening & roofing. The framework of the floor mainly consists of pillars 'tham' and beam 'dalin '. Though the masonry walls are load bearing in nature, the timber columns are also used for carrying the load. The columns are either square or rectangle in section. The sizes of section vary according to the span of beam. The spacing of the columns is not regular as that of a Newari house in the Kathmandu valley. They vary according to the nature of space. Wooden brackets on the posts give better support to the main beam, which are supported on the ends by additional posts. The joists are usually round sections of 15 cm diameter, placed 45 cm apart.





**Figure 6. Wooden Post with carved bracket supporting Beam**

Source UNDP/ERRRP: Indigenous Knowledge and Technologies for Safer Buildings

- 4) **Roofing Material:** As the amount of rainfall is very less, the roof is made flat. The roof is supported by load bearing walls along with the interior wooden columns. Wooden beams, joists, planks are used in roof to transfer the load of mud roof. In the construction of roof, after the layout of required number of wooden joist wooden planks are kept above it. Above this plank or 'chirpat' a layer of straw or dry grass is kept, above this mud is kept & finely compacted. The quality of mud is improved with the addition of dry grass or straw particle while mixing with water. It reinforces the mud particle & makes it stronger. At the top, one layer of 'shakhar mato' is kept & made roof water proofing. These layers of roofing material are maintained periodically.
  
- 5) **Doors and Windows:** As the masonry wall is load bearing very few openings are made for door & windows. The main entrance door on the ground floor is situated nearly at the center of the house. The doors are made of wood and are not carved. The main entrance door is bigger than rest of the doors for other rooms. The windows at external façade are small and simple whereas those facing the courtyard are big and beautifully carved. The ground floor has no windows, but all openings are provided towards courtyard.
  
- 6) The terrace is flat, and piles of logs are kept at every end of the terrace which works as a railing and used to represent the socio-economic status of the house owner in the past days. The flat mud roof is one of the most important elements of the building in this region. As, rainfall is minimum, & external environment is very cold; the mud roof is

eco-friendly. Its insulating property conserves the heat inside the building so that comfort environment is achieved

## 5. Earthquake Safety Measure

- 1) This house is more than 100 years old and still standing without any cracks. This shows that local materials and local technologies used in this residence has achieved certain level of perfection for this type of small house. Construction techniques used in this house by local mason has been outcome of experience of so many years of construction practice in this region which led this house to stand for such long span.

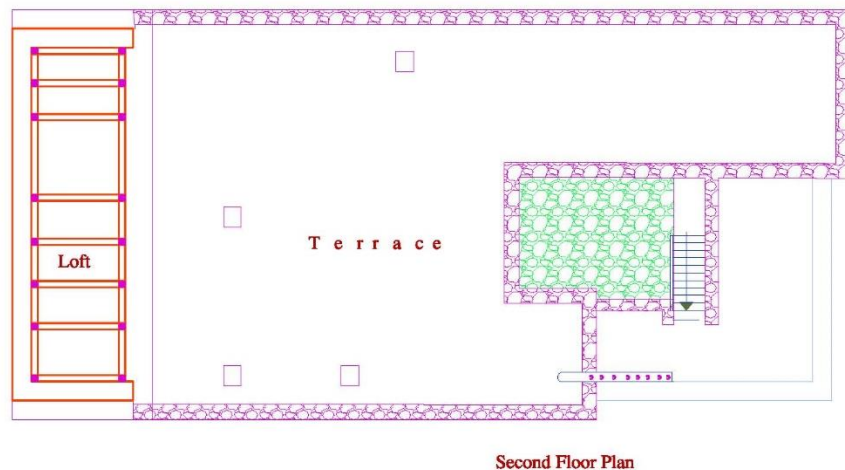

**Figure 7. Second Floor Plan of Residence in Marpha**

*Source UNDP/ERRRP: Indigenous Knowledge and Technologies for Safer Buildings*

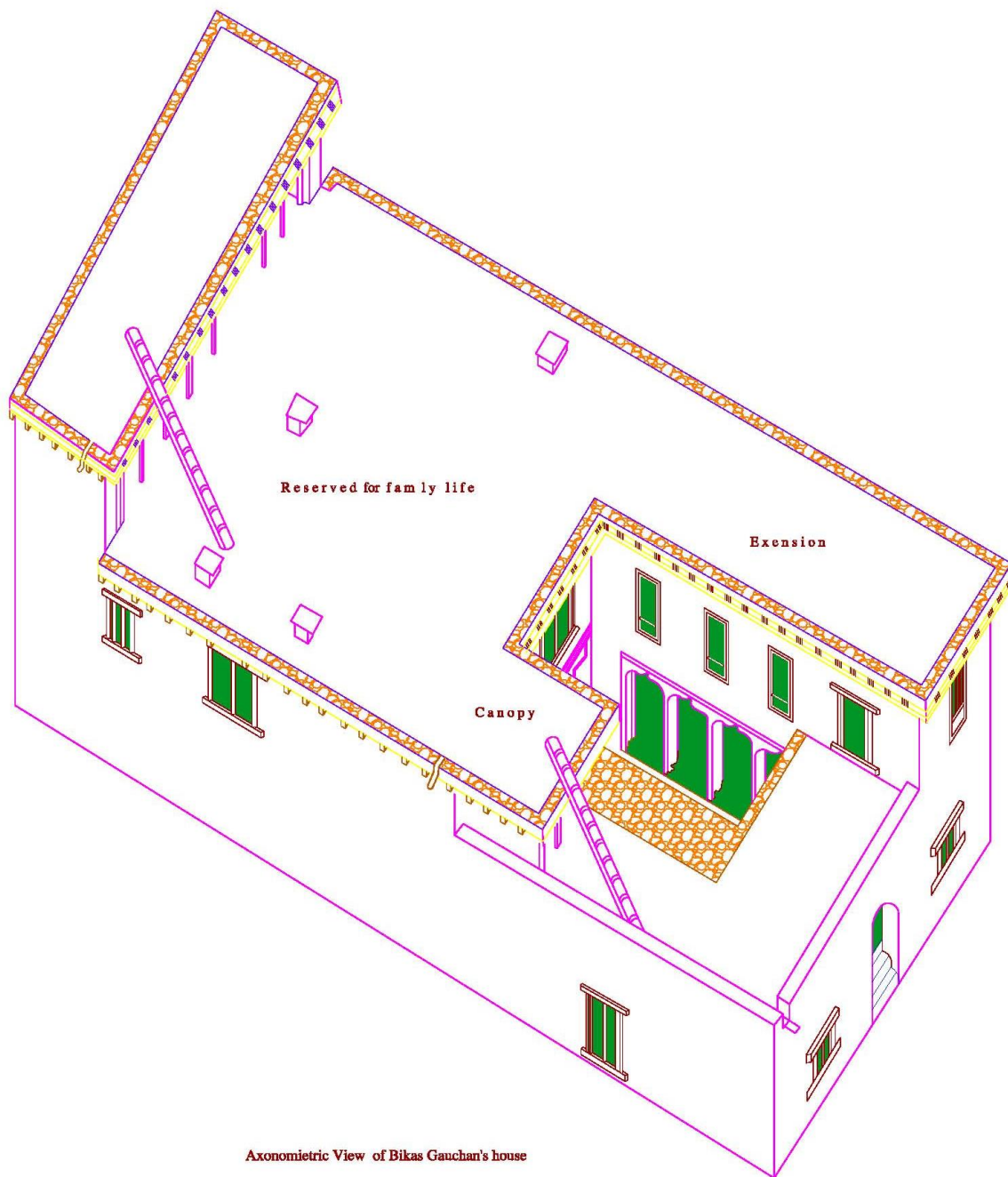

Axonometric View of Bikas Gauchan's house

**Figure 8. Axonometric View of Residence in Marpha**

Source UNDP/ERRRP: Indigenous Knowledge and Technologies for Safer Buildings



## 4.1.2 Indigenous Architecture of Hilly Region

### 1) Introduction

- 1) Most of area of Nepal is in the hills, where fifty-three percent of the population lives. Within this region there is a great deal of variation in climate, topography, and other conditions. Still, it is possible to discuss hill architecture in a general way. A hill house must protect its inhabitants from a wide range of weather conditions. Temperatures in hilly areas fall below freezing point in winter. In the hot months twenty-five degrees Celsius is not uncommon in some areas. Rainfall varies greatly from one hill area to another. Some never experience snow, others expect it. In yet others, hail stone are an annual threat. Severe climatic conditions of all types are intensified by high winds.
- 2) As might be expected, buildings in the middle hills are generally sturdier affairs than those in the Terai. Stone is the most common material used in construction in the middle hills. It is almost always used for building foundations; it is the most common material for walls and exterior paving and is often used as a roof cladding. The characteristics of the local building stone vary from place to place; hard durable and suitable for dressing in one place - rotten and full of sand pockets in another. This variation in local stone is well illustrated by comparing the stone roofs they are thin in section (therefore relatively light) but hard and durable. They can be dressed to regular shapes with simple tools.

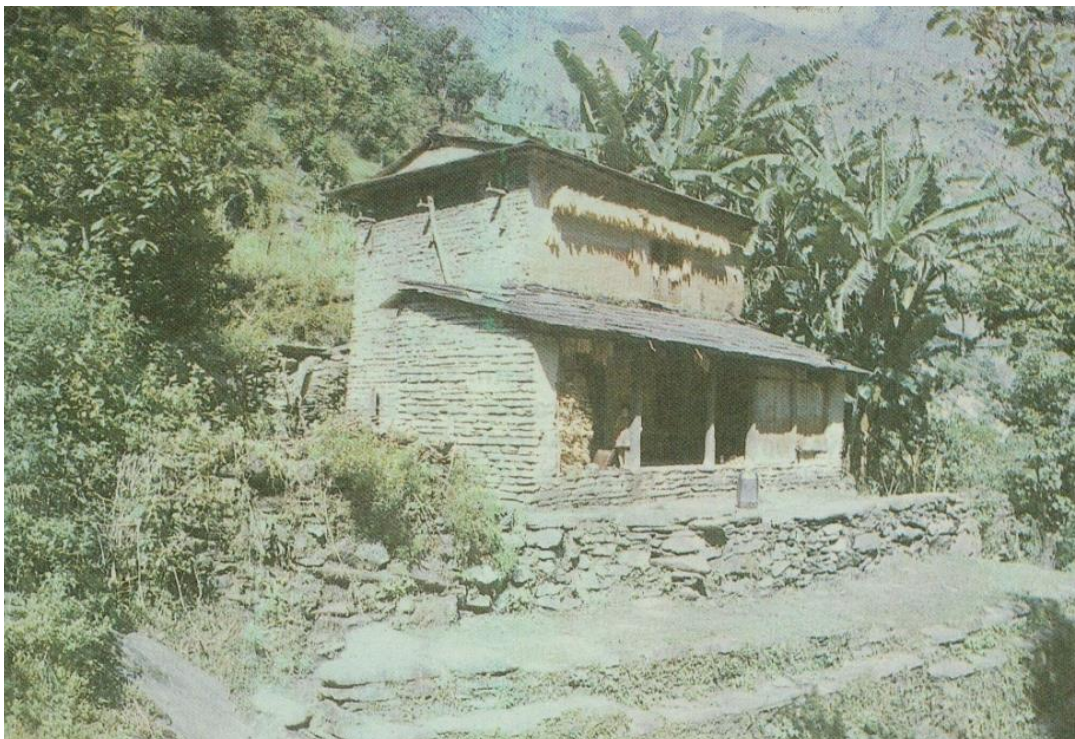

**Figure 9. View of Typical Residence in Hilly Region**

*Source UNDP/ERRRP: Indigenous Knowledge and Technologies for Safer Buildings*



- 3) A typical dwelling in the middle hills has a foundation of boulders laid in mud mortar. The stone bearing walls, perhaps half a meter thick, have few small openings and set far away from the corners. Quoins are neatly dressed, but random rubble masonry with rough stones is most common. The house, seldom more than two stories high, may be roofed with thatch, burned tile, slate, and in some cases wooden boards. Most often it is a saddleback roof, with the overhang carried across the gable ends as a skirt. Verandahs are popular in many hill areas, as are balconies which often serve as the roof for a verandah. Such verandahs are closed on their back side by the front of the house while the end walls of the house extend forward to close the sides.



**Figure 10. View of Typical Residence in Hilly Region**

*Source UNDP/ERRRP: Indigenous Knowledge and Technologies for Safer Buildings*

- 4) Ideally, such houses are oriented so that the balcony and verandah provide shade from the hot summer sun while the walls give shelter from high wind. In cold months, the welcome warmth of the low winter sun is admitted.

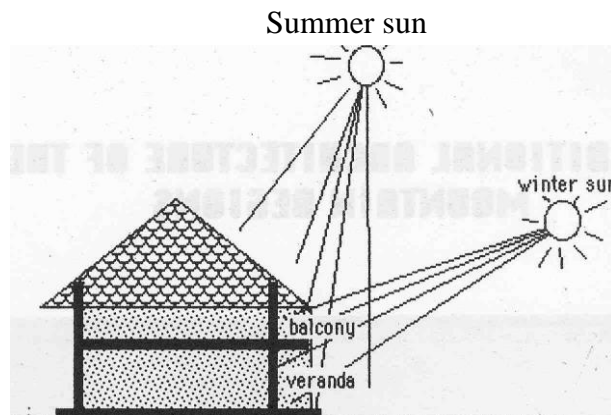

**Figure 11. Orientation of Sun in verandah of Residence**

*Source UNDP/ERRRP: Indigenous Knowledge and Technologies for Safer Buildings*

- 5) This attention to balconies and verandas is necessary. In a farmer's house much important household works are performed in such areas since in addition to the temperature control features described above, they are well lit, relatively free of kitchen smoke, and convenient for social interaction. Ceilings are seldom more than six feet high in the hills. Low ceilings keep warm air close to the floor which makes space comfortable for living in cold weather.

## 2) Construction Materials and Technology

- 1) Materials used for building construction are indigenous type. Locally available materials like rubble sandstone, mud, wood and thatch (Khar) have used for construction. No material is imported; even nails were not used in the construction.
- 2) **Masonry work:** The load-bearing wall is built with rubble stone masonry in mud mortar. The thickness of wall is 45 cm. and have no corner and joints of wall as in other rectangular buildings. The rubble stone used for wall is of different size and shape. The walls are fully plastered with mud mortar externally and internally. The wall plaster is coated with white soil (Kamero Mato) and red soil (Rato Mato) which are found in the periphery of this site.
- 3) **Woodwork:** Besides wall, other supporting members like post, beam, joists, frames of door and windows are of local wood. Mostly locally available species like Chilaune, Katus and Uttis are used for timber. Three pillars in the ground floor support the beam and joist above it. The first floor is of mud flooring above wooden joists and wooden planks.
- 4) The roofing materials are thatch and timber which are locally available. Wooden members support the roof load along with the wall. A row of three pillars supports the ridge beam transversally. Size of rafter and purlins at ridge and middle part are larger than rafter and purlins at lower part.



**Figure 12. View of Oval Shape Residence**

Source UNDP/ERRRP: Indigenous Knowledge and Technologies for Safer Buildings

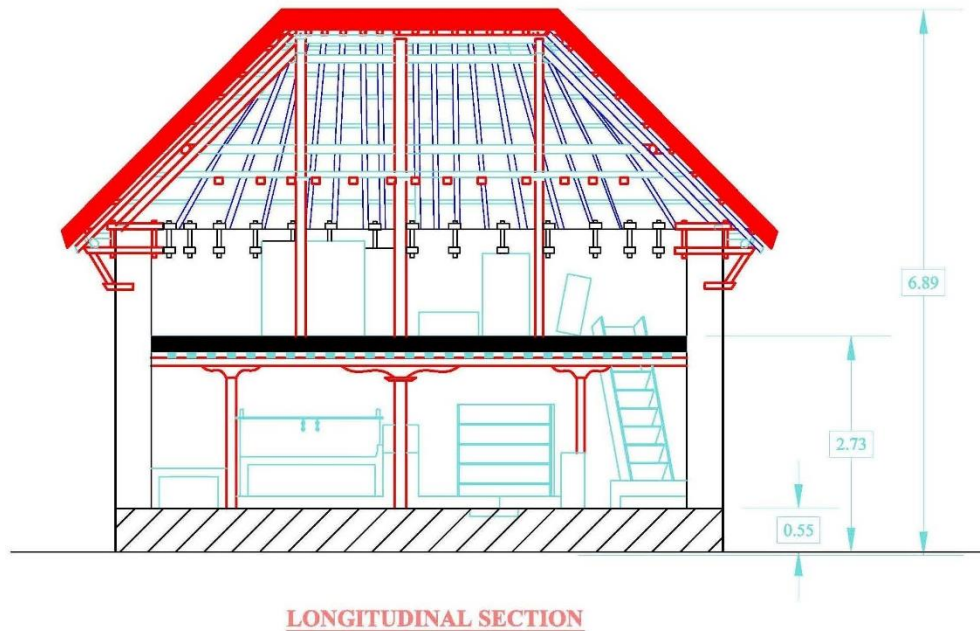

**Figure 13. Longitudinal Section of Oval Shape Residence**

Source UNDP/ERRRP: Indigenous Knowledge and Technologies for Safer Buildings

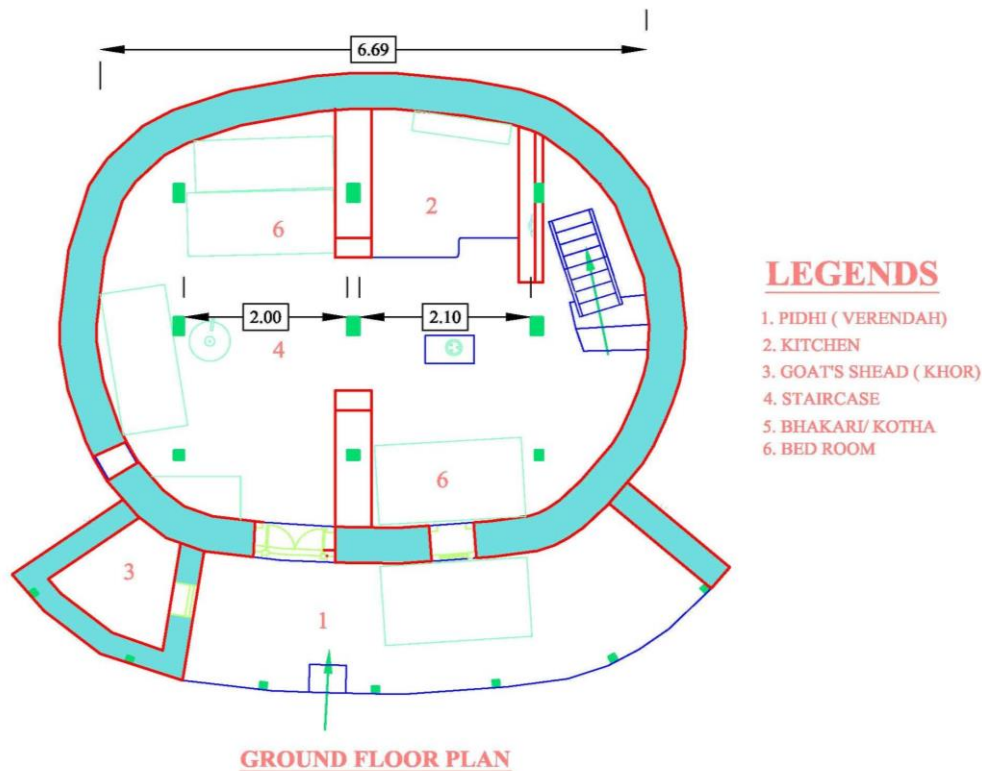

**Figure 14. Ground Floor Plan of Oval Shape Residence**

Source UNDP/ERRRP: Indigenous Knowledge and Technologies for Safer Buildings

- 5) Usually the dimensioning unit is 'Hath', generally odd number (e.g. 11, 13, 15, 17 and so on) is followed for the construction of house. This oval shaped is constructed within a square of 17 hath x 17 hath. Roof overhangs are provided to protect wall from high annual rainfall (more than 4000 mm). The front facade wall is plastered with mud mortar and coated with Kamero and Rato Mato while all the openings are painted black. This gives beautiful color combination of black, white, and red band. No cracks are seen in walls till date. Above the Verandah there are three small windows arranged symmetrically. These beautifully carved windows access minimum light and ventilation. The central window has two openable shutters but two side windows are lattice type (Aakhi Jhyal). Continuous cornice of wooden and stone cornice is provided above the windows. All the exterior part of the windows is beautifully carved with different motives. The struts supporting roof projection also has carvings.
- 6) At the sill level of these windows, 12 inches' width horizontal band platforms are providing. The main door is very small and has low height. The clear opening is only 65cm by 125 cm. The door is also beautifully carved. The window at right side of verandah is (50cm by 75cm) lattice type. The verandah is finished with mud flooring. It is raised 55

cm above from aagan level. The aagan is paved roughly with flat stone slab and is used for social gathering.

- 7) Nine posts are supporting first floor load along with the wall around. The floor to ceiling height of ground floor is only 1.65 m. The low height stone masonry wall separates the kitchen space from other spaces. The first floor has open space without any partition. Three king posts support the roof ridge beam. The top of the wall is tied with wooden members embedded in the wall. Ridge beam and wall plate on wall supports main rafters of the roof. There are four types of wooden members one above another, principle rafter, large purlins, small rafter and small purlins. Thatch is kept above the netting made of split bamboo.

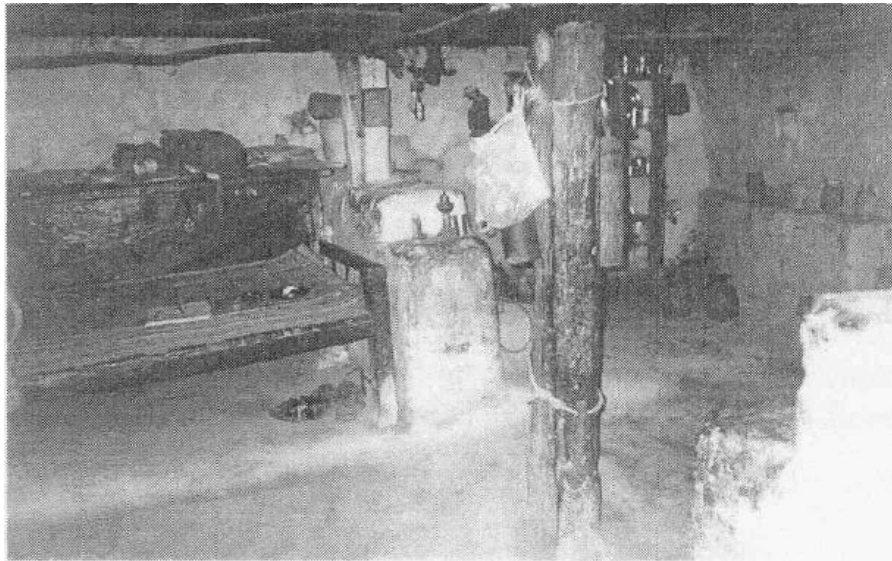

**Figure 15. View of Kitchen of Oval Shape Residence**

Source UNDP/ERRRP: Indigenous Knowledge and Technologies for Safer Buildings

- 8) In this building, the space is broadly classified into four categories: Aagan, Pidhi, Bhui Talla and Aati. As explained already, the Aagan and Pidhi spaces are open to all, but internal spaces are more sacred. Pidhi is transitional space between inside and outside. After getting entry through door, one reaches open area which is used for gathering and sitting for people of touchable caste. Three posts at the Centre of ground floor divides the whole area into two halves longitudinally. The rear half is more scared than initial which is slightly raised. A wooden stair at northeast corner leads to first floor. Primarily first floor is used as food-grain storage purpose. As it is damp proof it is best space for storing food.





**Figure 16. Detail of Pillar and Rafter Joint**

Source UNDP/ERRRP: Indigenous Knowledge and Technologies for Safer Buildings

### **4.1.3 Indigenous Architecture of Terai Region**

#### **1. Introduction**

- 1) When malaria was nearly eradicated from the Terai in recent decades, the area was open for human settlement on a bigger scale than was ever possible. During the same period, large tracts of tropical rain forest were cleared. Migrants from other parts of the country moved into the area, erecting buildings of various types. Some of these were clever adaptations of the houses built by indigenous Terai peoples, others such as those built by ex-servicemen took for their model buildings they had seen in other tropical lands.
- 2) Needless to say, these buildings met with varying degrees of success in coping with the tropical monsoonal climate by protecting the inhabitants and their possessions from heat and heavy rainfall. Those buildings that seem best suited to the region tend to have some features in common.

- 3) Some of the common features are the post and beam structure with wattle and daub infill. The variations on this theme seem endless, and one can see many types of reed, grass, stick, stalk and crop residue tied or woven into place and plastered over with mixtures of mud, rice husk, and cow dung and sometimes lime. Wide roof overhangs shade exterior walls from the direct rays of the sun. Verandahs, formed by extending the roof still further, provide a comfortable place to sit and work by day and, in some cases, to sleep at night.

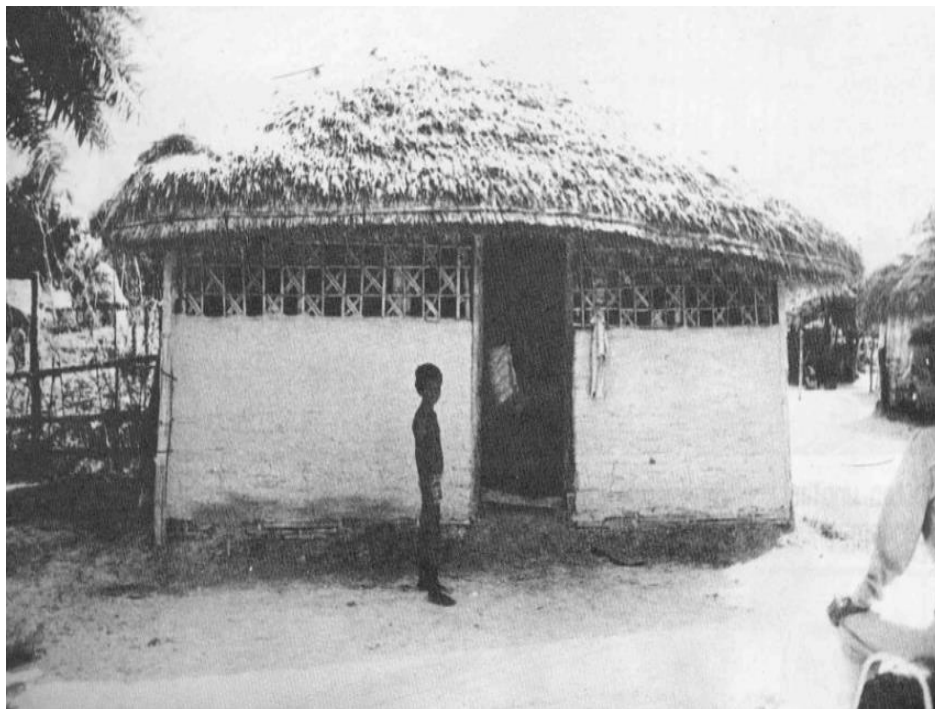

**Figure 17. View of Typical Residence of Terai**

Source UNDP/ERRRP: Indigenous Knowledge and Technologies for Safer Buildings

- 4) The upper portion of an exterior wall which is shaded by the roof is made of bamboo strips, loosely woven into an open mesh which provides some security while permitting light and air to enter. Often unplaster walls of wood or reed are loosely constructed with many random gaps and cracks for the same purpose. Houses built on wooden pilings from three to ten feet above the ground are not uncommon. Besides allowing air to circulate all around the house and keeping the floors out of the damp, snakes and other unwelcoming guests find it difficult to enter such houses. The shaded space under the house (either left open or partially walled to form a lower floor) serves as a useful work area.
- 5) Shade, so welcome in a hot climate is often created by building close to trees, or conversely by planting trees around the buildings. Clusters of buildings shade one another and form semi-enclosed compounds. The people with high income build their homes with bricks as walling material.

- 6) Thatch is by far the most common roof material (not just in the Terai or in Nepal, but in the whole world). In addition to being cheap and easily available, it provides insulation from the sun's heat. The lightness of thatch makes it unnecessary to use heavy timbers in the roof structure; un-sawn poles cut from the jungle or bamboo is most common. Thatch roofs in Nepal have a life of between two and six years, after which they need to be replaced. The quality of the thatching material used and the skill with which it is placed determine the serviceable life of a roof. Paral (straw) is the commonest thatching material in Nepal. A paral roof lasts for two or three years only, but it is cheap to replace, Malwas, a kind of grass found in parts of the Terai last for five or six years but is not so cheap or abundant as paral.
- 7) Tile roofs are also common in the Terai, these are of two types, one being a flat pan tile, and the other, a half cylinder similar to those seen in Mediterranean countries. The hipped roof is the most common type encountered in the Terai. This design permits high ceilings which assist circulation of air and wide roof overhangs for shade, without the necessity of high gable walls. Floors in most Terai buildings are of compacted earth, although wealthier people use clay tile, or cement plaster over stones.



**Figure 18. View of Dhangadi Residence of Terai**

Source UNDP/ERRRP: Indigenous Knowledge and Technologies for Safer Buildings





**Figure 19. View of Verandah in Dhangadi Residence**

Source UNDP/ERRRP: Indigenous Knowledge and Technologies for Safer Buildings

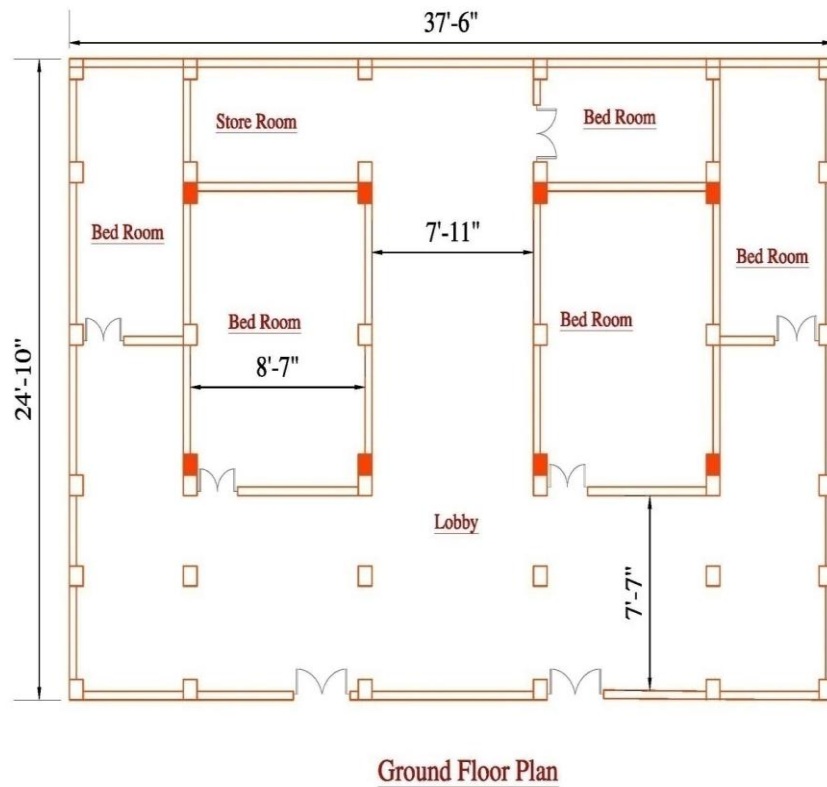

**Figure 20. Ground Floor Plan of Dhangadi Residence**

Source UNDP/ERRRP: Indigenous Knowledge and Technologies for Safer Buildings

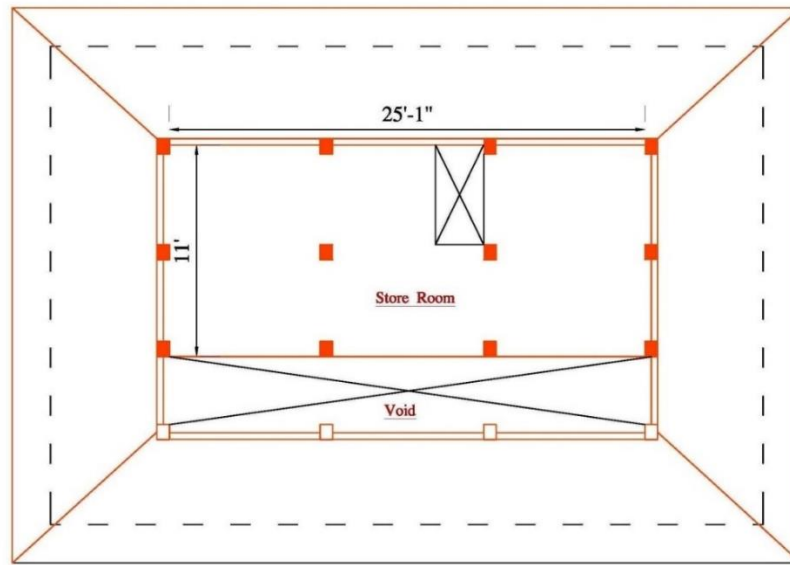

**First Floor Plan**

**Figure 21. First Floor Plan of Dhangadi Residence**

Source UNDP/ERRRP: Indigenous Knowledge and Technologies for Safer Buildings



**Figure 22. Two timber posts**

Source UNDP/ERRRP: Indigenous Knowledge and Technologies for Safer Buildings

## 2. Construction materials and technology

- 1) The walls are light structure and are tied to wooden posts or pillars. The roof load is supported by the wooden joists, resting on beams. The load on beams is being transferred to the ground by means of twelve numbers of wooden pillars. The floor is constructed of mud above wooden planks.
- 2) Wooden post of 8"x 9" are laid in six rows. Wooden post for floor and roof is placed next to each other and are separated to carry the load individually. Wooden rafter of 3" x 3" are nailed to the beam at 2' center to center. 10" x 12" clay tiles are used for roofing. No large windows are kept on east and south side. Small opening is provided in first floor for cool area on north side of building.

## 3. Earthquake Safety Measure

- 1) **Shape:** The building is symmetrical in plan and regular in elevation.
- 2) **Proportion in plan:** The breadth to length ratio of the building is within 1:3. The breadth to length ratio of any room or area enclosed by load bearing wall is also with in 1:3. The building height is not more than three times the width of the building.
- 3) **Storey height:** The floor to floor height of the building is in between 2 to 3 m.
- 4) **Foundation:** The foundation is not required for wall and depth of foundation for pillars are 3 to 4 feet.
- 5) **Position of openings:** Openings are not located at corner or junction of wall.
- 6) **Load path:** The structure contains one complete load path for life safety.
- 7) **Horizontal bands:** There are wooden bands located at sill and lintel levels.
- 8) **Corner stitch:** There are at least three stitches on wall all around the building.
- 9) **Gable band:** Wooden gable band is not used on slope roof. Since the structure is load bearing timber structure and is light and flexible to earthquake shakes. Though no special design is found against the earthquake, but it can be said to be safe against small shakes of earthquake.

## 4.1.4 Newari residential Buildings of Kathmandu Valley

### 1. Introduction

- 1) The Newars, the primary settlers of the Kathmandu Valley, are considered to be one of the most ancient ethnic groups of Nepal. Though they comprise only four per cent of the population, they are the most culturally renowned and are credited with the craftsmanship of great Nepali monuments. A traditional Newar town is laid out so as to conserve as much arable land as possible. Towns are densely packed together, with narrow streets and a central square that serves as the public open space. Individual houses have no private outdoor spaces in ground floor.
- 2) A typical house selected and explained is four storied along the old street of Kathmandu. The original Newari building has remained relatively unchanged over the centuries up to modern times. Most of the houses kept the same appearance for centuries. This was mainly due to similar building methods and materials, and a steady and uniform way of living. This house does not share common walls with adjacent buildings and has front and back façade free. This building type forms part of an urban block of adjacent buildings arranged in rows. Due to location of the house in street, part of ground floor is used for shop and backside is open used for other household activities. This traditional Newari house is of rectangular shape in plan. The depth of the plan is about 20' with façades of 25'. The organization of the house is in vertical direction with a spine wall running through the height, creating front and back rooms. The first floor is divided into two parts by an interior load bearing wall. The first floor is traditionally used as bedrooms. The room on back side of the house is further sub divided into smaller rooms which are used for sleeping and storage. The second floor, with the greatest natural light from its large ornately carved wooden windows, is used as living room and for visitors' reception. The San jhya is always in the center and it creates therefore a central axis for the symmetry of the Newari facade. A feature of the San Jhya window richly decorated window that spans most of the facade with seating space framed within it. In third floor there is large room with columns replacing the interior bearing wall used for kitchen and small terrace. The floor has only one dormer window and light level is quite low. The staircase is a single flight on one side of the plan. The floor-to-floor height of storey is 7'0" including the floor structure. This vertical stratification of space keeps smoke out of the living space and accommodates the Hindu social system whereby outsiders are excluded from the kitchen and more intimate areas.

### 2. Construction materials and technology

- 1) This house has a stone foundation, brick walls, and a wooden substructure that supports clay floors and tile roof. The house is simple load bearing structure.

- 2) **Foundation:** Residential houses have longitudinal foundations made of stone blocks in trenches of 60" wide and 39" deep at an average. Such foundations are supposed to carry the weight of the buildings down to hard ground, similarly foundation have been raised about 24' from ground in order to preserve and protect the base of the brick walls from dampness. The heavy monsoon rain during the four months was the single most important determinant of the form and the materials used in the Newari house. Rains affect the structure from the top down and bottom up.
- 3) **Walls:** The masonry wall is of 24" thick with the combination of sun-dried brick and fired brick. The burnt brick is of standard size and often measures 9"x 4.5" 2.5". Inner wall is constructed with sun dried brick. The internal loads are carried by an internal spine wall structure on the ground, first and second floors and by columns on the third floor. The interior walls are finished with mud and dung plaster.
- 4) **Floor:** In this house floors are finished with telia tile in third floor and rest of floor have clay laid on top of wooden planks. Floors are supported by wooden Joist, whose section varies from 3."x 3." to 4' x4" and this is further dependent on the distance which separates their supports. Perpendicular to these joists split bamboo or split timber are arranged on which the surface of earth is spread which directly constitutes the ground. Depending on the principle of construction adopted, the joists are separated by 8" to 9".
- 5) Just before reaching the height of the joisting, girders are placed on the last row of bricks in order to tie the facade walls and the internal partition walls in their longitudinal direction and to obtain a regular support at the joist end. It is on such girders that the joists are placed. One out of about every four joists is joined in the preceding piece by the pins or wedges, intended to join the three walls together. In the upper storeys, where the middle wall is interrupted, the joists rest on a beam supported by columns. Here once again one joisting out of every four is provided with pins which go right through the beam. Henceforth these pins are not only used to tie the walls, but also to maintain the beam and columns in their vertical position.
- 6) **Roofing Material:** The roof is covered with waterproof clay tiles and is sloped to shed water. The slope of the roofs is of 25°. Due to short span the rafters are not very long. Timber joists (dimensions 4" x 3") run from wall to wall at closely spaced intervals of 6" to 8". Above the joists either planks or a bamboo chirpat are covered by compressed mud. The roof overhangs protect the wall below from direct water penetration during the monsoon and direct sun on the rest of the year. Structurally, most elaborate part of the house is the roof frame. The weight of the clay tile with 4"-5" thick mud mortar and large overhang of roof are supported by angled struts. Intricate wood detailing and large overhanging roofs are distinctive of Newar buildings. This distinctive roof form is both an aesthetic and functional building method which protects all sides of the building from rain and makes the most efficient use of wood. It combines the simplicity of the gabled roof

framing with the advantages of the hip roof, without the need for long hip beam members. The resulting, graciously skirted, wood, tile and brick buildings have become an aesthetic symbol of the Kathmandu Valley.

- 7) **The Dalan:** Among the many striking timber construction details of traditional buildings in the Kathmandu Valley, the dalan is certainly the most obvious and interesting in structural terms. The dalan is a timber frame made of twin wooden columns surmounted by a capital on which sits a double beam. The two adjacent timber frames are usually connected only at the level of the beam. The dalan is most commonly found at the ground floor of the main facade of buildings in which the front room is used as a shop or workshop. The columns usually have a square cross section of about 4" x 4" at the minimum and 6" x 6" at the maximum, and they are pinned to the ground. The capital and the beam are also connected to the column by timber pins and the joists of the floor above sit directly on the beam. Therefore, the first-floor joists directly support the façade of the upper storeys. The dalan usually takes most of the width of the building with only small masonry piers of about 200 mm width restraining it laterally and connecting it to the rest of the masonry box. In seismic terms the dalan can be compared with modern concrete soft storey structure and its associated failure mechanism, as all connections are simply pinned; the only lateral restraint, when present, is represented by the shear strength of the masonry piers at the edge of the façade.
- 8) **Opening Size and Window Frames:** Window openings vary in size depending on the period of construction. Older buildings have generally smaller square windows with lintels extending well into the surrounding masonry. These are usually built with a double frame, one within the external masonry leaf and a slightly larger one within the internal masonry leaf. The two frames are connected by timber elements embedded in the masonry. The size of the windows within a story may vary, depending on the use of the room. A feature of older buildings is the San Jhya window a richly decorated window that spans most of the facade at the third-story level with seating framed within it.



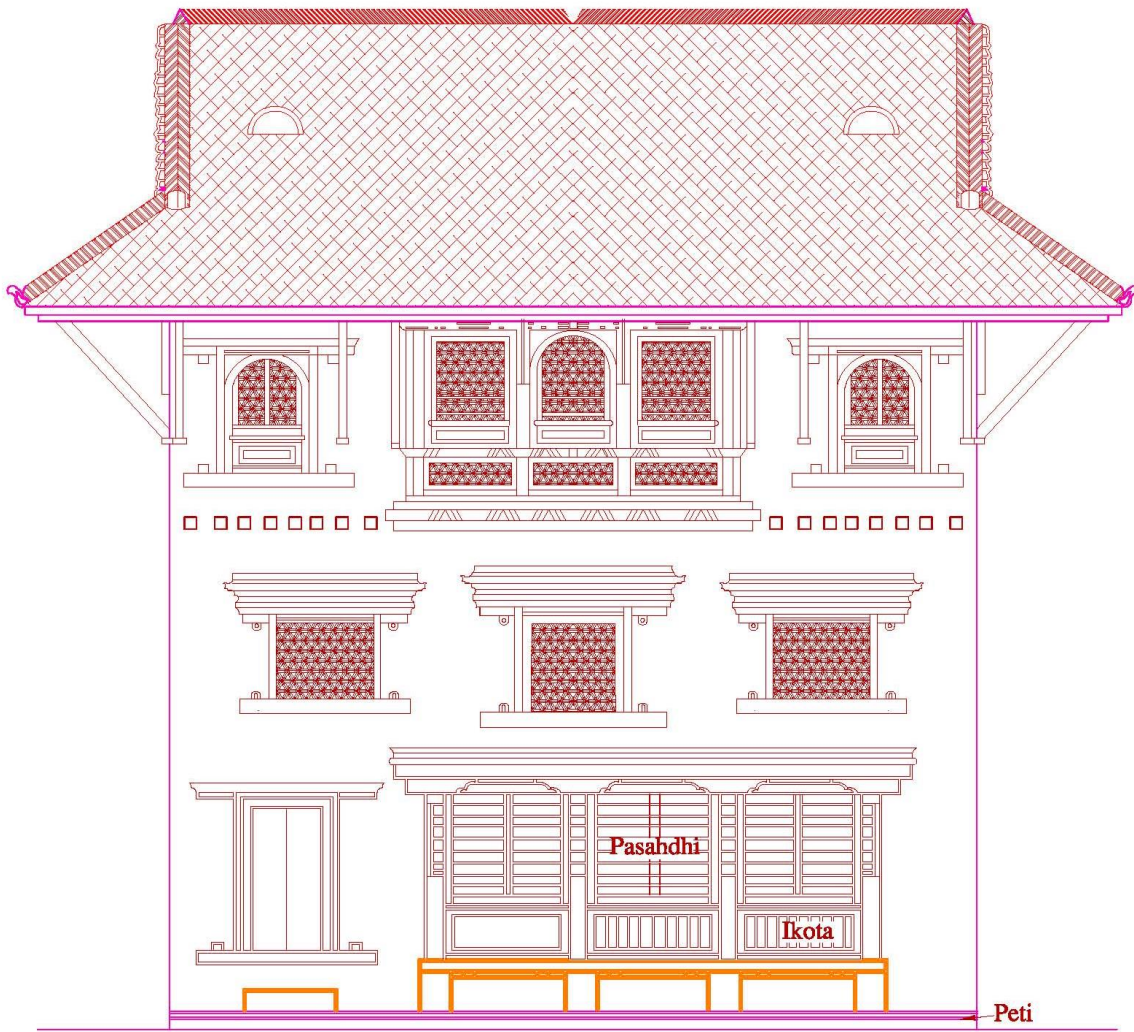

## Newari House Elevation

**Figure 23. Elevation of Newari Residence**

Source UNDP/ERRRP: Indigenous Knowledge and Technologies for Safer Buildings

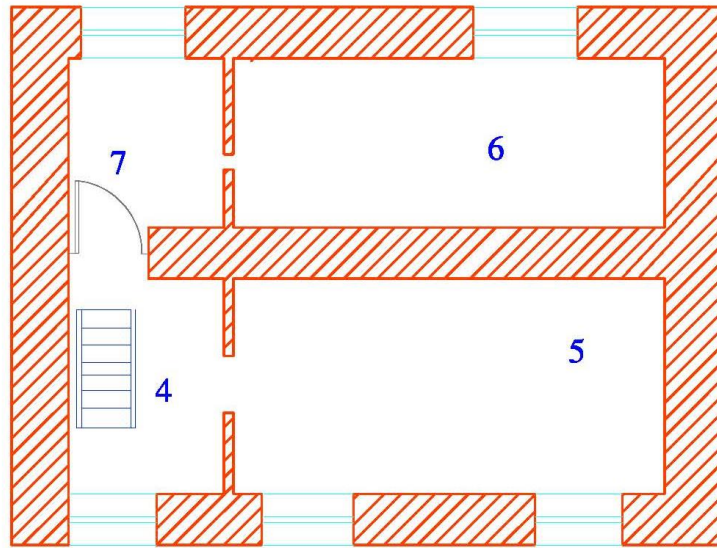

**First Floor Plan**

1. Entry
2. Shop
3. Open storage
4. Hall
5. Siting / Sleeping
6. Sleeping / Grain storage
7. Sleeping / Grain storage

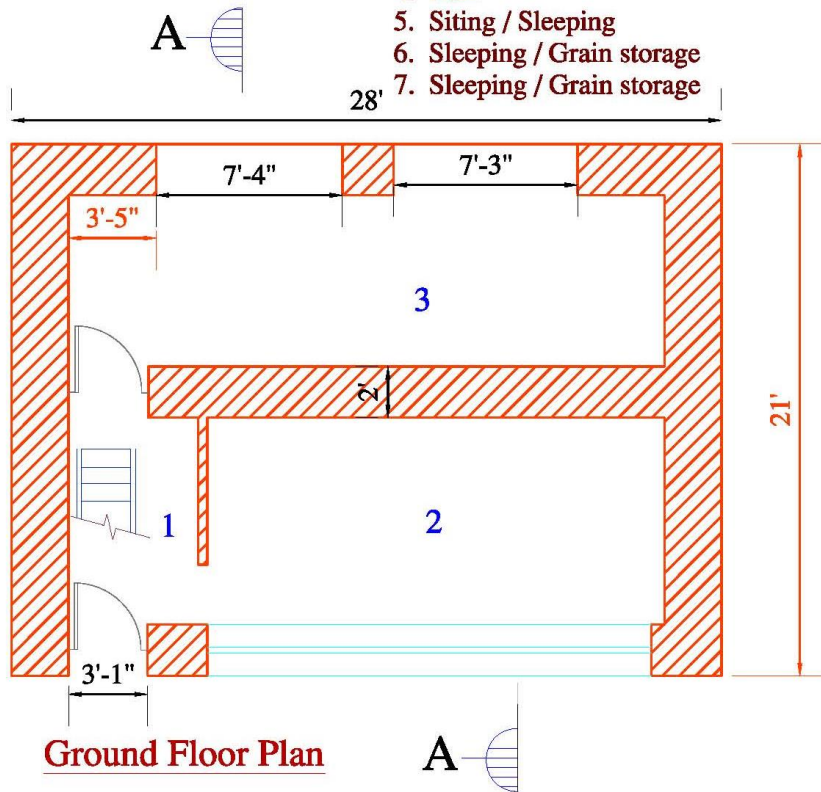

**Ground Floor Plan**

**Figure 24. Plan of Newari Residence**

Source UNDP/ERRRP: Indigenous Knowledge and Technologies for Safer Buildings



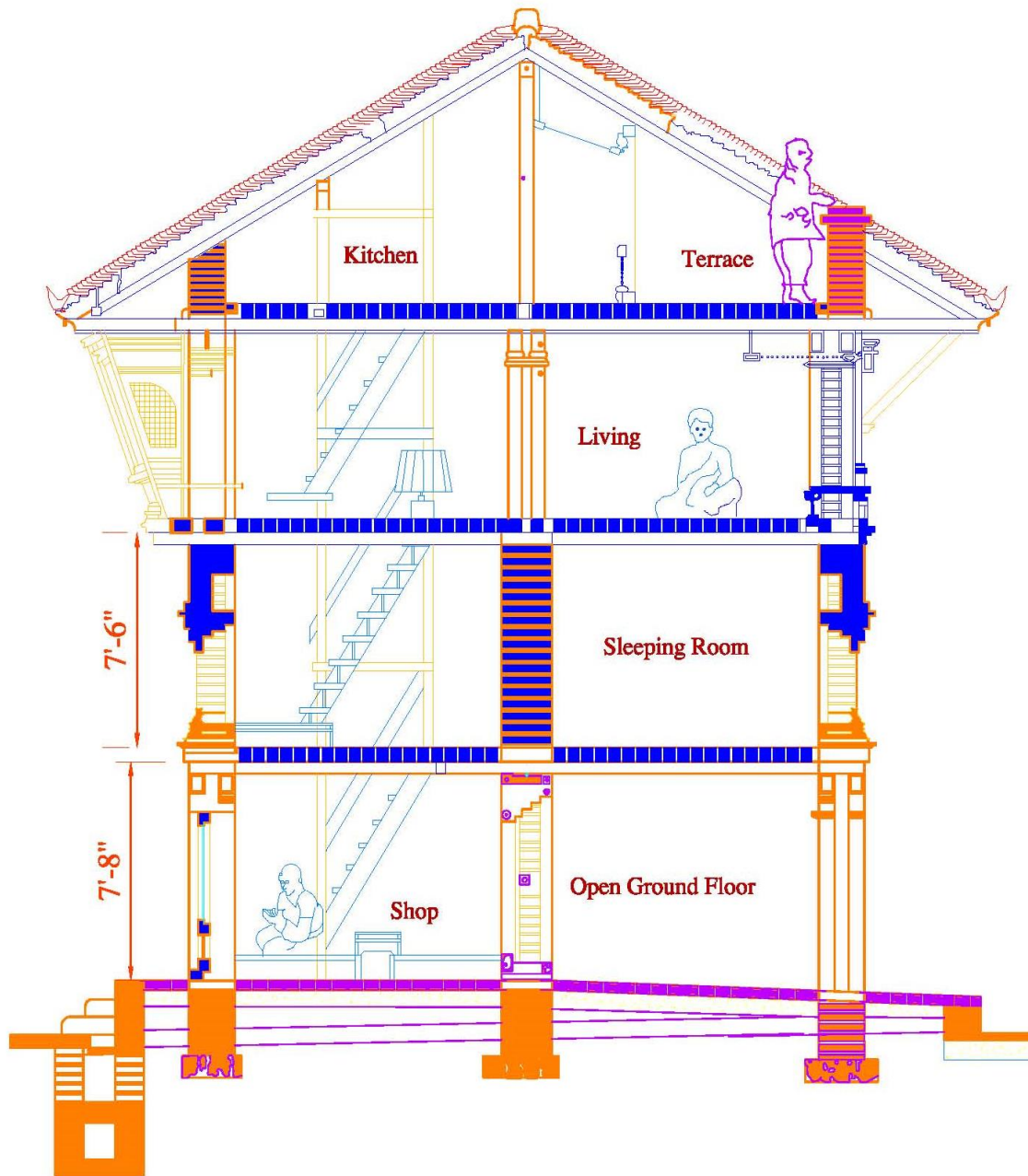

**Section :- A-A**

**Figure 25. Section of Newar Residence**

Source UNDP/ERRRP: Indigenous Knowledge and Technologies for Safer Buildings

### 3. *Earthquake Safety Measure*

- 1) The most interesting characteristic of these buildings both from an architectural and seismic point of view is the presence of the timber frame. Usually at ground floor, timber posts are provided on the facade to create open space for workshops or shops. It is also found internally at the upper storeys. In some cases, the masonry only forms the outer shell while the internal structure is all made of timber elements.
- 2) The lateral load-resisting system is un-reinforced masonry walls. There is no distinction between the lateral load resisting system and the gravity load-bearing structure. The masonry external walls fulfil both roles. In these traditional buildings a number of construction details, of connections between masonry walls and timber floor structures are aimed at improving lateral load-resisting capacity. The presence of horizontal timber bands to brace the masonry is not found in this residential building. However, the traditional openings have a double frame system one flush with the outer skin of the wall, one with the internal skin, and these are connected by transversal timber elements. These features are best preserved in older buildings. From the seismic point of view most of residence buildings were built in high land and in hard soil.

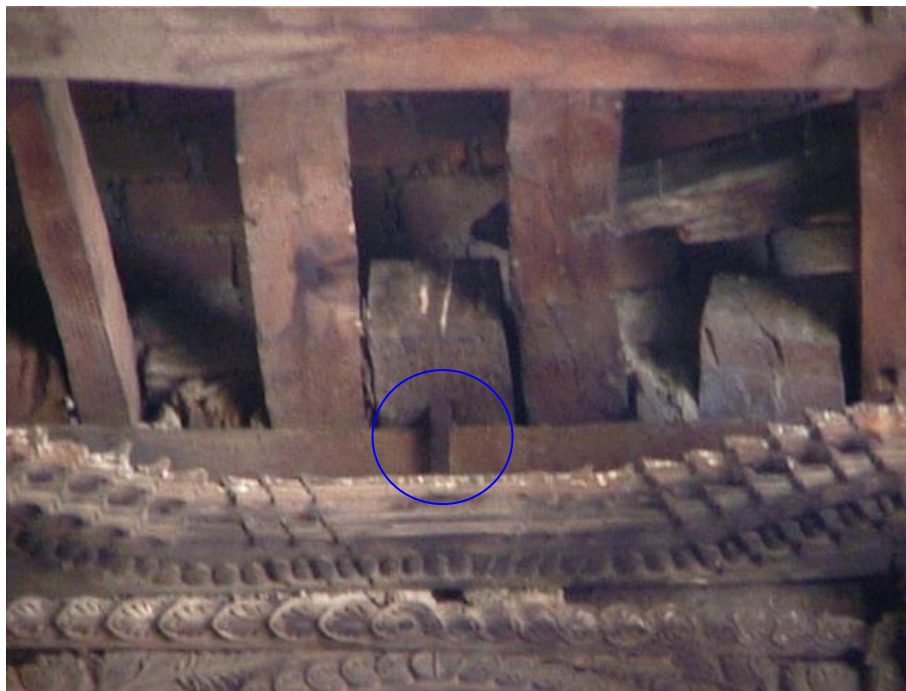

**Figure 26. Detail of timber peg connecting joists to walls.**

Source UNDP/ERRRP: Indigenous Knowledge and Technologies for Safer Buildings



**Figure 27. Detail of timber post in the dalan structure.**

Source UNDP/ERRRP: Indigenous Knowledge and Technologies for Safer Buildings



**Figure 28. Photograph of a residential street in Lalitpur after the 1934 earthquake**

## 4.1.5 Identification of different earthquake risk reduction technologies used in temple, palaces and residential Building of Kathmandu Valley

### 1. Introduction:

Different earthquake risk reduction elements used in Palaces, temples and residence of Kathmandu Valley are described below.

- 1) **Wall thickness:** - Wall thickness whether residence or Palace is maximum at the ground floor and decreases with succeeding upper floors. As the horizontal thrust at the ground level develops highest at the time of earthquake in a building the greater thickness reduces the shear failure at that time.
- 2) **Mud mortar:** - Generally in all structures, mud is used as mortar in between bricks. Mud is very weak in strength as compared to the strength of brick and timber. In case of greater thrust the mud mortar cracks and helps to displace wall thus absorbing the thrust. This causes partial collapse preventing total collapse of the building.
- 3) **Wooden elements:** - Traditional structures have many wooden components like beams, joists, lintels, beautifully carved doors, windows, and pillars. Most of these wooden members tie the brick walls making them work as single unit. It prevents the distortion or displacement of walls in case of earthquake. The flexibility of wooden members can absorb some external forces by bending itself and comes to its original shape after the force is released. It helps from breaking the wall. Even in case of breakage, the timber components prevent from total collapse, i.e. partial collapse takes place.
- 4) **Symmetry:** - For earthquake resistant design, it is important that center of mass and center of rigidity of building is nearly coincident (center of rigidity is defined as geometric center of stiffness of various elements of building). If it is not so, the distance between center of mass and center of rigidity will cause torsion in the building. However, this torsion problem is well taken care of in many traditional structures of Kathmandu valley by having same size of opening in opposite wall that is the openings have been symmetrically arranged around the centerline of the structure, thus making the rigidity of opposite walls the same. This causes no excessive torsion because the center of mass and center of rigidity coincides in traditional tiered temple and residential building.
- 5) **Shape of Building in plan:** - The plan of traditional houses and temples are generally rectangular, and some are even square, which is very good from the earthquake safety point of view. The ratio of length to breadth is generally less than 2.
- 6) **Double Framing of Openings:** - Great care has been taken in design of openings since jambs of openings are the critical section of a wall panel during earthquake. Traditional houses, Tiered Temple, and Palaces of Kathmandu and Bhaktapur have two complete frames of timber (tied to each other) around the openings to strengthen it against lateral force. Also, location of openings has been carefully controlled keeping all windows at least 3 feet away from corners so as not to weaken them.





**Figure 29. Double Framing in Door**

Source UNDP/ERRRP: Indigenous Knowledge and Technologies for Safer Buildings

- 7) **Roof held tightly to the Wall:** -Generally during strong earthquakes, sloped roof tend to slide off the wall thus shearing the wall element also in the process. However, in many traditional Newari houses, roof is held tightly to wall by extensive use of wedges and tie members.
- 8) **Use of "Chukus" or Wedges:** -One remarkable feature of the traditional houses of Kathmandu is the system of "Chukus"- that is the timber wedges used to secure various joists in timber member. Generally, floor joists are held tightly to wall by putting wedges on both sides of the wall rather than inserting inside it. This way, the joint becomes a pinned joint rather than a rigid joint, because if one blows up the joint between wedges and wall there will still be a tolerance between the walls and wedge. Due to this gap between wedge and wall, load transfer from one wall to another will not be complete until the floor joists moves through this tolerance (or gap) during earthquake. In this process of moving the floor joist by the tolerance distance, some energy will be absorbed by the floor joist which is equal to the work done in moving the joist- that is seismic force x tolerance distance. Thus this mechanism of wedges serves a dual purpose of providing structural integrity between floor joists and wall, and at the same time absorbing some portion of earthquake energy thus reducing the earthquake effect on the building.



**Figure 30. Wooden Peg fixed against Rafter supported by struts**

Source UNDP/ERRRP: Indigenous Knowledge and Technologies for Safer Buildings

- 9) The joint system in wooden wedges has certain advantages over that with nut and bolts. They are:
  - The wooden wedges do not rust like nuts and bolts in course of time.
  - Wooden wedges have the same coefficient of expansion as the wooden joists to which it is fixed, whereas iron bolts have different coefficient of expansion with respect to wooden joist. Hence during temperature changes, wedges are better than iron bolts.
  - Wedges, unlike rigid joints in nuts and bolts are ductile in property, and have slight flexibility of movement, which is desirable for earthquake resistance.
- 10) Traditional architecture still stands today and is relevant because it has always addressed sustainability. It is that of necessity in most cases where local craftsmanship and building materials are vital and spaces always mirror the true and practical lifestyles of their inhabitants. The relevance of good traditional building is that it not only allows us to celebrate our past technological achievements but also to study and understand the primary mechanisms which guarded the design of the particular building.

- 11) In earthquake prone countries like Nepal, Indigenous architecture has typically evolved over centuries, with recurring construction details that testify to the viability which directly respond to the seismic hazard of these regions. These features, which enable ordinary buildings to withstand seismic shaking, were developed and modified through centuries of direct experience and observation of damage.
- 12) On the basis of the above mentioned traditional technology we can say that our ancestors have learned a lot about the earthquake safety construction techniques although they did not know the complex calculation of modern earthquake safety designs.
- 13) These indigenous technologies which have learnt from their own experiences and had been modified time to time should be taken as reference and do the modification as per present context and advance knowledge of earthquake engineering.



#### 4.1.6 ips for Earthquake Resistant Construction of RCC frame Structure Buildings



Source: Technical Poster, DUDBC

# 1. Construction of Foundations

- Minimum cover to main reinforcement shall not be less than 50 mm for surface in contact with earth face. However, it may extend upto 75 mm when bottom of the footing is in direct contact with the soil.
- Minimum diameter of main bar is 12 mm.
- Minimum area of reinforcement in footing slab is 0.12% of concrete area.
- The reinforcement bars of columns should be extended into the footing to a distance not less than development length of the bar.
- However, the development length can be modified in ratio by providing more reinforcement than required.
- Special confining lateral ties provided to the column shall extend at least 300 mm into the footing and should not more than 100 mm c/c.
- If footing pads of two columns overlap each other, combine footing will be provided. In the case, foundation will be one of following two types:
  - Combine Footing pad with reinforcement mesh in bottom plus strip beam
  - Combine footing pad with Two layers of mesh in top and bottom of the footing pad
- In case, column locate in boundary of property land, strap or cantilever footing will be provided combining the footing with footing of adjacent column via strap beam.
- For combine footing with strip beam, detailing of longitudinal and transverse bars is similar to that of beams.
- All footing of a building should be kept as same horizontal level as far as possible unless designed and prescribed by the structural designer.

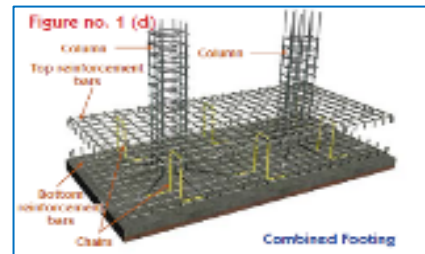
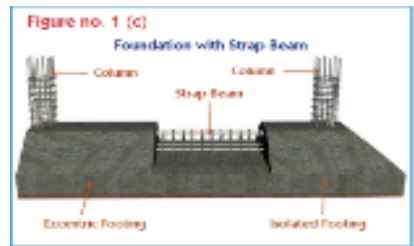
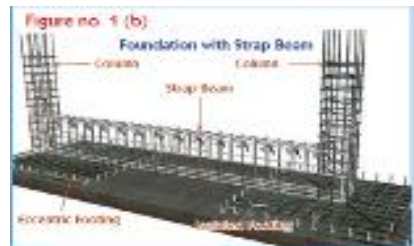
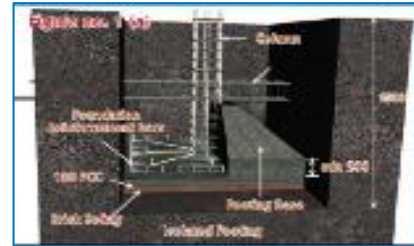

Source: Technical Poster, DUDBC

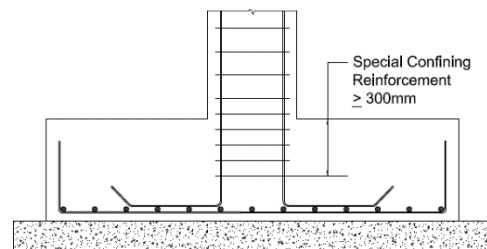

Source: NBC 105, MOUD

## 2. Construction of Columns

- Minimum dimension of a column shall not be less than  $20d_b$ , where  $d_b$  is diameter of the largest diameter of longitudinal reinforcement bar in the beam passing through or anchoring at the joint. However, minimum dimension of column shall be 300 mm.
- Rectangular columns shall have a minimum of 8 numbers of bars.
- Minimum diameter of the longitudinal bar shall be 12 mm
- Transverse reinforcement shall have  $135^\circ$  hook ends with as extension of 6 times its diameter (but not less than 65 mm) at each end, which are embedded in the confined core of the column. Minimum diameter of hoop shall be 8 mm.
- Maximum spacing of parallel legs of the links/hoops shall be minimum of 300 mm c/c and half the least lateral dimension of the column.
- Spacing of the confining reinforcement shall be minimum of  $B_c/4$ ;  $6d_b$  and 100 mm,  $B_c$  is smallest cross-sectional dimension of column,  $d_b$ =diameter of smallest longitudinal bar of column
- Special confining reinforcement shall be provided over a length ( $l_o$ ) minimum of  $D_c$  (Largest cross section dimension of the column); Clear length of the column  $l_{cl}/6$ ; 450 mm from the face of the joint towards mid height of the column on either side of the joint.

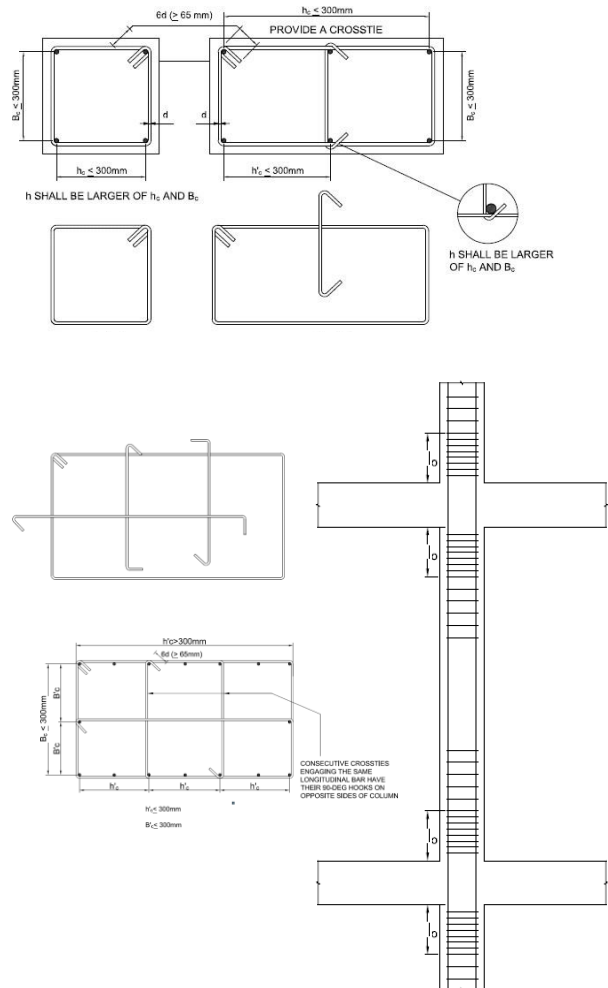

Source: NBC 105, MOUD

## 2. Lapping in Columns

When longitudinal steel bars have to be continued for spans larger than their manufactured lengths, the bars shall be connected by either splicing or mechanical couplers.

- Maximum 50% of bar numbers can be splice in a location.
- Lap splices shall not be provided
- Within a joint
- Within a distance of  $2d$  from face of the column/beam
- Lap splices shall be provided only in the central half of clear column height
- Closed links/stirrups/hoops shall be provided over

the entire length of the beam/column over which the longitudinal bars are spliced.

- The lap length shall not be less than the development length of the largest longitudinal reinforcement bar in tension.
- The spacing of these links shall not exceed 150 mm.

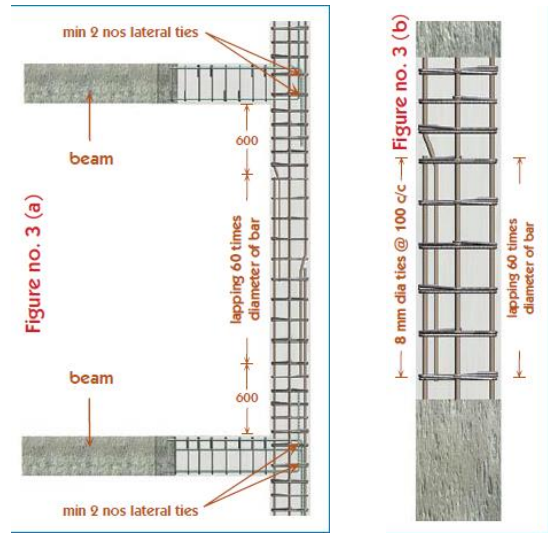

Source: Technical Poster, DUDBC

### 3. Construction of Beams

- Longitudinal steel on bottom face of a beam framing into a column shall be at least half the steel on its top face at the same section.
- Longitudinal steel in beams at any section shall be at least 1/4th of maximum longitudinal steel provided at the beam.
- Vertical stirrups shall be used in beam as transverse reinforcement.
- Stirrups are permitted to be made of two pieces of bars also namely U-link with a 135° hook with an extension of 6 times diameter, but not less than 65 mm, imbedded in the core and across-tie.
- The hooks of the stirrups and crossties shall engage around peripheral longitudinal bars. Consecutive cross ties engaging the same longitudinal bars shall have their 90° hooks at opposite sides of the beam.
- The minimum diameter of a transverse reinforcement shall be 8 mm.
- Closely spaced links shall be provided over a length equal to 2d from column face on either side. Spacing of links over the 2d length shall not exceed the minimum of (d/4; 8db; 100 mm). The first link shall be at a distance not exceeding 50 mm from the joint face.

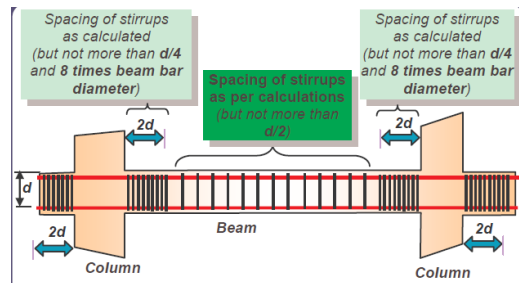

Source: IITK, BMTPC/Earthquake Tip

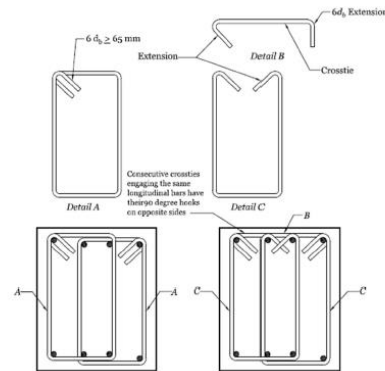
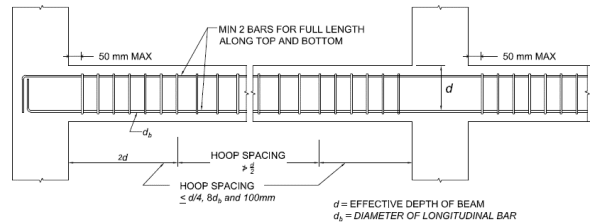

Source: NBC 105, MOUD

#### 4. Lapping in Beams

- Reinforcement bars at bottom should not be lapped at mid-1/4 span of beam and should be lapped at edges 600 mm away from column faces.
- Reinforcement bars at top should be lapped at mid-1/3 of span of beam.
- The lapping length should be 60 times the diameter of reinforcement bars (for concrete mix 1:2:4). The spacing of vertical stirrups should be 100 mm c/c through the length of lapping.
- The minimum size of stirrups should be 8 mm diameter.

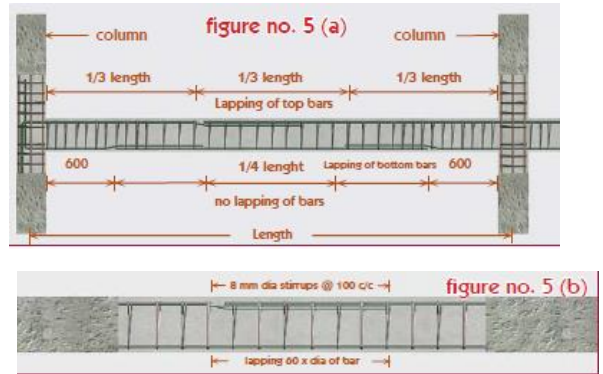

Source: Technical Poster, DUDBC

#### 5. Beam and column joint

- At an exterior joint, top and bottom longitudinal bars of beams shall be provided with horizontal length beyond the inner face of the column, equal to horizontal development length ( $l_{dh}$ ) terminating in a standard hook of length  $12d_b$ .
- The hook shall be located within the confined core of a column or of a boundary element with hook bent into the joint.
- If the requirements for  $l_{dh}$  cannot be satisfied in the exterior beam-column joint, the beam can be extended horizontally in the form of exterior stubs
- Lateral ties should be provided at the interval of 100 mm. within joints

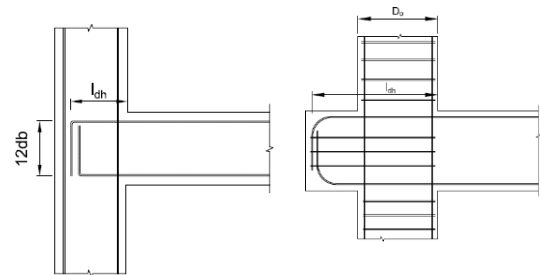

Source: NBC 105, MoUD

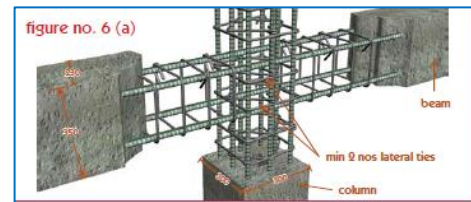

Source: Technical Poster, DUDBC

Development Length,  $l_d = (l_{dh} + l_{db})$

for 12 mm  $\varnothing$  bars,  $l_d = 421$  mm.

for 16 mm  $\varnothing$  bars,  $l_d = 561$  mm.

$L_{dh}$  Calculation

Concrete Grade	Rebar Grade	$L_{dh}$
M20	Fe 500	$23.05 \times \varnothing$
M20	Fe 415	$19.13 \times \varnothing$
M25	Fe 500	$20.62 \times \varnothing$
M25	Fe 415	$17.11 \times \varnothing$



## 6. Sill and Lintel Bands

- To prevent the infill walls toppling down out of plane these shall be provided with horizontal reinforced concrete (RC) bands through the wall at about one-third and two-thirds of their height above the floor in each height (at sill and lintel level of openings).
- The RC bands should be tied up with columns abutting the wall by anchoring longitudinal bars fully with U-bars projected from columns.
- The width of the band should be equal to the wall thickness and its thickness equal to that of the masonry unit or 75mm, whichever is larger.

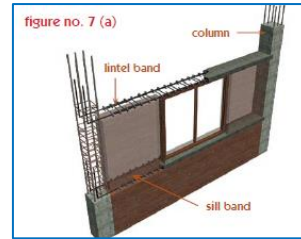

## 7. Construction of Parapet Bands

- Parapet bands should be provided to prevent toppling down of parapet walls at terrace and walls at verandahs.
- Concrete posts of size 230 x 75 mm with 2 nos. 10 mm diameter tied with 8 mm diameter U-hooks at 150 mm spacing should be erected from beams/slabs at 1200 mm spacing.
- The concrete posts should be tied up at top with 75 mm thick horizontal concrete bands with 10 mm diameter bars tied with 8 mm diameter U-hooks at 150 mm spacing.

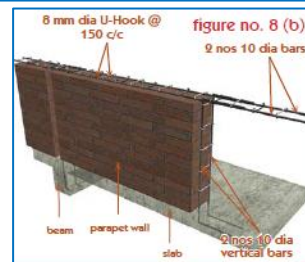
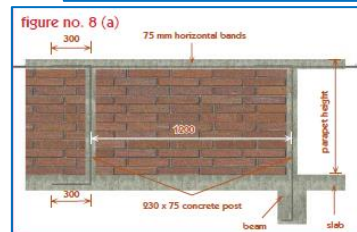

## 8. Construction of Slab

- For slab panel of size 4.5 m x 3.0 m, reinforcement bars of 8mm diameter can be provided at 150 mm spacing.
- For slab projections up to 1.0 m extra bars of 10 mm diameter should be provided.
- Chairs (10 mm diameter) should be provided for positioning the top bars as shown in the figure.
- Cover blocks (1 Cement :1 Sand Mortar) of 15mm thickness should be used for bottom bars.

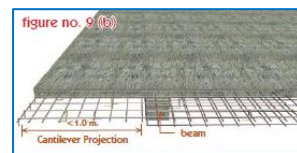
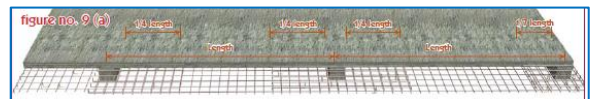

Source: Technical Poster, DUDBC

## 9. Construction of Staircase

- The minimum thickness of waist slab should be 125 mm.
- Top bars should be curtailed up to 60 times diameter length or 1/3 length of slope portion of waist slab which is greater measured from starting/ending of slope.
- Bottom bars should be provided continued from beam to beam.
- Nose bars of 10 mm diameter should be provided at every step tied up by 8 mm diameter binders at 300 mm spacing as shown in figure no. 10 (b).

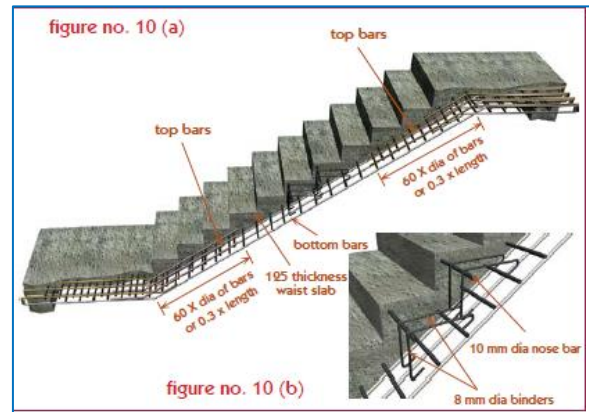

Source: Technical Poster, DUDBC



**4.1.7 Tips for Construction of Earthquake Resistant Construction of Load Bearing Masonry Structure Residential Buildings up to three stories**



Source: Technical Poster, DUDBC

## 1. Construction of Foundations

For one storied building, the recommended size of foundations are as follows:

- Width 750 mm and depth 800 mm for brick masonry with cement mortar
- Width 750 mm and depth 800 mm for stone masonry in cement mortar
- Width 850 mm and depth 800 mm for brick masonry with mud mortar

For building up to three stories, the recommended size of foundations are as follows:

- Width 900 mm and depth 900 mm for brick masonry with cement mortar
- Width 900 mm and depth 900 mm for stone masonry in cement mortar
- Width 1050 and depth 1050 for brick masonry with mud mortar. The buildings with brick masonry in mud mortar should not be constructed more than two stories
- 75 mm thick Plain Cement Concrete (P.C.C.) in 1:2:4 ratio of cement sand aggregate should be laid over one-layer Brick flat soling for constructing brick masonry in foundation

## 2. Construction of Tie Beams

- Tie beams should be provided for tying up the walls with each other and preventing dampness coming up from ground to superstructure
- The level of tie beam should be usually 450 mm to 750 mm from ground level
- The width of the tie beam should be equal to the wall thickness and its minimum thickness equal to 150 mm.
- 4 numbers 12 mm. diameter steel bars should be provided with 8mm. diameter vertical stirrups at 150 mm spacing.
- Tie beam should be constructed with concrete in ratio 1:1.5:3 cement, sand and aggregate.

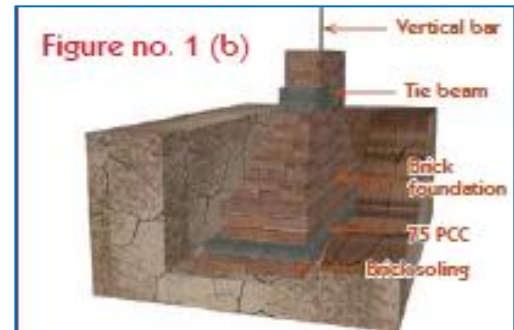
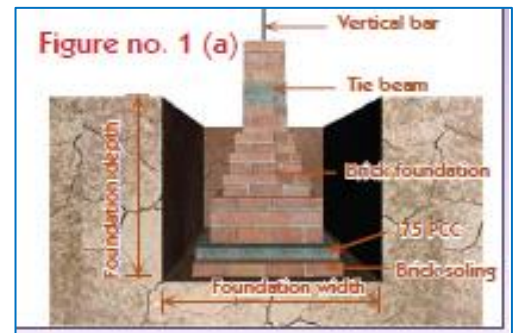

Source: Technical Poster, DUDBC

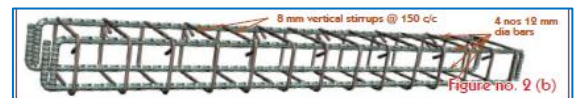
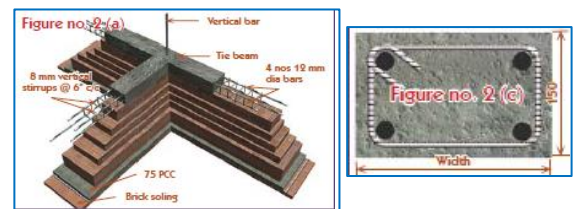

Source: Technical Poster, DUDBC

### 3. Thickness of Wall

- For brick masonry in cement sand mortar (1:6) the thickness of wall should be 350 mm at ground floor and 230 mm at first and second floors the width of room should not exceed 3.5 m.
- For stone masonry wall in cement sand mortar (1:6) the thickness of wall should be 450 mm for ground floor and 350 mm for first floor. It is safe to construct maximum two floors with stone masonry and the width of room should not exceed 3.5 m.
- For brick masonry with mud mortar the thickness of wall should be 350 mm. at ground floor and 230 mm at first floor. It is recommended to construct maximum two floors with brick masonry in mud mortar



Source: Technical Poster, DUDBC

### 4. Locations of doors and windows in wall

- The doors and windows should be placed at minimum 600 mm distance away from wall corners and joints.
- Gap between two openings: Wall length between any two openings (doors and /or windows) should not be less than 600 mm. i.e. door and windows in a wall should be placed at 600 mm apart from each other horizontally.
- The total length of doors and windows in a wall should not be more than 50% for single storey construction.

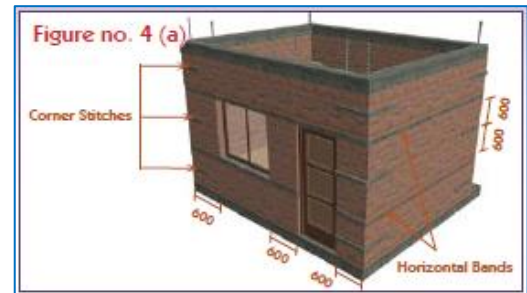

Source: Inspection Manual, NRA

## 5. Concrete Stitches at Junctions and Corners

- Concrete stitches should be provided at junctions and corners of walls.
- The width of the stitches should be equal to the width of the wall and its thickness equal to that of the masonry unit or 75mm, whichever is larger. The length of the stitch should be 900 mm, from the corner or junction of the walls
- 2 numbers 10mm diameter bars with 8mm diameter U-hooks at 150 mm spacing should be provided for stitches
- The concrete stitches should be provided at every 600 mm height of wall

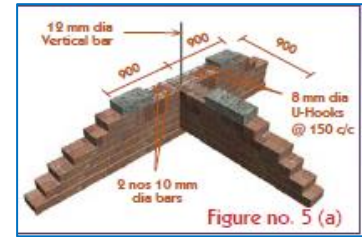

Source: Technical Poster, DUDBC

## 6. Floor Beams

- Floor beams should be provided through the whole length of wall with floor slabs
- The width of the beams should be equal to the width of the wall and height should be equal to minimum 325 mm.
- Reinforcement bars should be provided as shown in figure no. 6 (a)



Source: Technical Poster, DUDBC

## 7. Sill and Lintel Bands

- Sill and Lintel bands should be provided at sill and lintel level of openings
- The width of bands should be equal to the thickness of wall and thickness should be 75mm. At openings more than 1.2 m the thickness of lintel bands should be equal to 150 mm at opening with 450 mm bearing in either side.
- 2 numbers 12mm diameter reinforcement bars with 8mm diameter U-hooks at 150 mm spacing should be provided for sill and lintel bands.
- For lintel bands of 150 mm thickness, 4 numbers 12 mm diameter with 8 mm diameter vertical stirrups at 150 mm spacing should be provided.

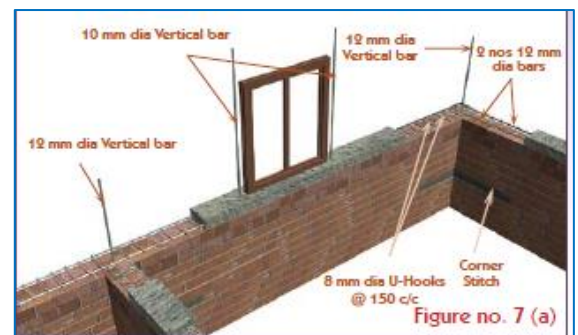

Source: Technical Poster, DUDBC



## 8. Vertical Bars

- Vertical bars of 12mm diameter should be provided at every corners and junctions of the walls from foundations to top of the slab
- Vertical bars of 10mm diameter should be provided at the side of openings from tie beams to slabs
- Concreting (1:2:4) should be provided around the voids of vertical bars making 100 mmx100 mm reinforcement concrete (RCC) core.
- Usually construction of masonry walls should be constructed gradually in a level. Walls should be left in steps for continuation part as shown in the figures no. 8 (a, b).
- Walls should not be constructed more than 1.0 m height in a day

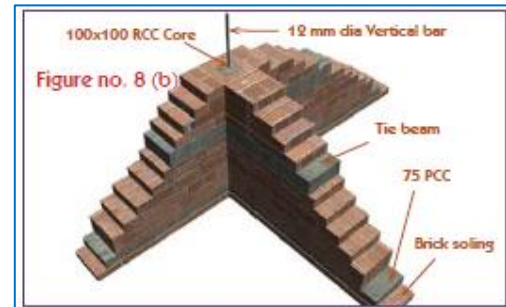
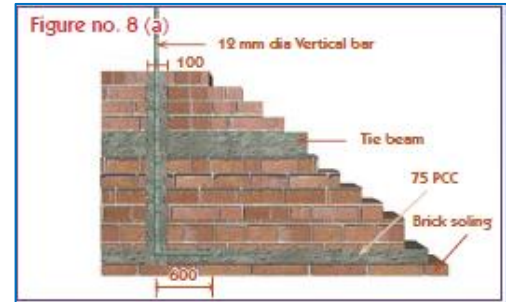

Source: Technical Poster, DUDBC

## 4.2 Cost Effective Construction Technologies

### 4.2.1 Reinforced Hollow Concrete Masonry

Hollow concrete blocks are precast concrete blocks with two large holes (40-50% cavity) which are open at top and bottom. Normally, the mix of 1:3:6 (cement: sand: stone chips) is used to get a minimum required strength of 50kg/sq.cm. These blocks are lighter than bricks, easier to place and also confer economics in foundation cost and consumption of cement. In comparison to conventional bricks, they offer the advantages of uniform quality, faster construction, less labor intensive and longer durability. Hollow concrete blocks can be used for a. Exterior load bearing wall b. Partition walls c. Column d. Retaining wall e. Compound wall Dimensions of Hollow Concrete blocks are a. Length: 400mm b. Height: 200mm c. Length: 100mm, 150mm and 200mm. Benefits of Hollow Concrete Block (HCB) Masonry:

1. Dimensional Accuracy Hollow concrete blocks are batch-produced in molds which means size can vary in only one plane, usually the height, as opposed to other products on the market that can vary in length, width and height. Permissible variation is +/-1.5mm on length and +/- 3mm on height.

2. Energy efficiency R.C.C frame structure and brick masonry consume 3 and 2 times more energy respectively as compared to hollow concrete masonry structure. Hollow blocks are also naturally energy efficient. The air gaps or the voids in blocks act as barrier between outside and inside environment. This effect of ensuring that buildings stay warm in winter and cool in summer lessens the need for artificial energy for heating and cooling.
3. Modular system Hollow concrete block masonry is a modular system which allows for efficient design and standardization of building components, such as door and window frames which then leads to cost efficiency. Modular co-ordination enables components to be built on site without modification, as well as reducing the range of sizes required.
4. Fire resistant Hollow concrete block masonry is fire resistant.
5. Cost Effective Hollow concrete block masonry is 18-to-20% cheaper than brick masonry. Hollow block masonry consumes lesser mortar as compared to conventional brick masonry because volume of joints. Amount of mortar is 25% of the total volume in brick masonry while only 10% in HCB masonry construction. In addition, the amount of plaster required for hollow block masonry is also lesser due to the evenness in the surface as compared to undulated brick masonry wall. Also, the speed of hollow block masonry is faster than brick masonry which also makes the construction economic.
6. Durability Hollow concrete block is highly durable material and is manufactured to resist local exposure conditions for the intended life of the building. Durability is generally related to compressive strength, which in turn is related to density. Surface protection such as paint and plaster adds tremendously to the durability of any walling material.
7. Environmentally friendly The production of brick consumes fertile soil that is valuable for cultivation. Large amount of firewood is required to bake the bricks which in turn lead to destruction of forest and the smoke emitted during the production leads to air pollution. None of these exist in the production of hollow concrete blocks.

### **Structural System of Reinforced Hollow Concrete Block Masonry:**

- 1) Hollow concrete block masonry structures can be easily made strong to resist earthquake and other vertical and lateral forces. The main property of hollow concrete block is that reinforcement can be easily placed at any position and make all the parts of the building function as structural members. Normally, the direct vertical force is not a problem as masonry can itself resist it. On the other hand, to resist lateral force like earthquake or eccentric forces (which produces tensile stress), steel reinforcements must be provided at the necessary positions and hollow blocks are the best for this purpose.
- 2) In this construction system, each wall and slab structurally behaves as a shear wall and a diaphragm respectively, reducing the vulnerability of disastrous damage to the building, during

natural hazards. Due to uniform distribution of reinforcement in both vertical and horizontal directions, through each masonry element, increased tensile resistance and ductile behavior of elements could be achieved.

- 3) Hence, this construction system can safely resist lateral or cyclic loading, when compared to other conventional masonry construction systems. This construction system has also been proved to offer better resistance under dynamic loading, when compared to other conventional systems of construction. Some construction photos of hollow concrete block masonry are illustrated below:

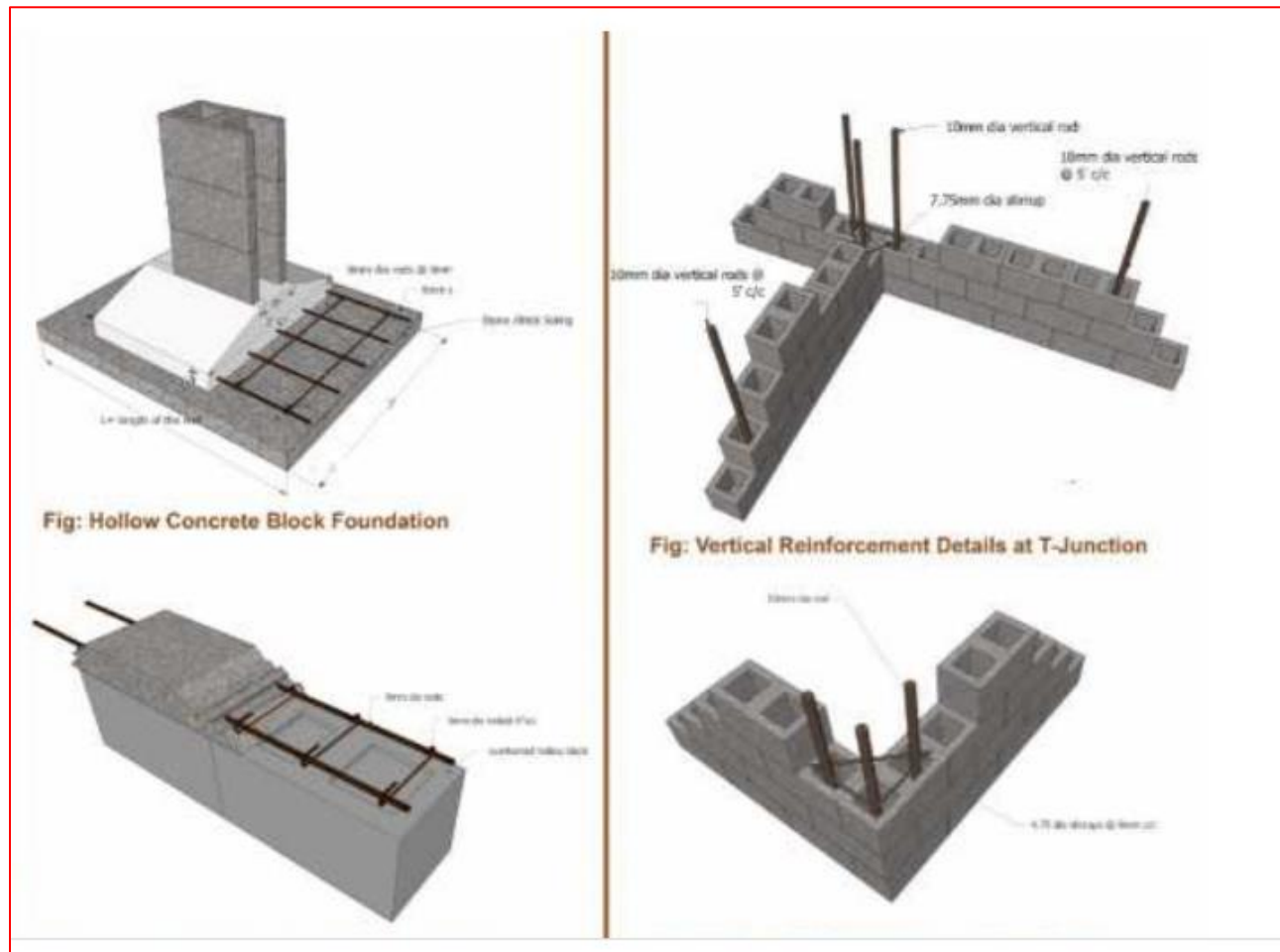

Source: Sewa Pvt. Ltd.



- 4) In this construction system, each wall and slab structurally behaves as a shear wall and a diaphragm respectively, reducing the vulnerability of disastrous damage to the building, during natural hazards. Due to uniform distribution of reinforcement in both vertical and horizontal directions, through each masonry element, increased tensile resistance and ductile behaviour of elements could be achieved.
- 5) Hence, this construction system can safely resist lateral or cyclic loading, when compared to other conventional masonry construction systems. This construction system has also been proved to offer better resistance under dynamic loading, when compared to other conventional systems of construction. Some construction photos of hollow concrete block masonry are illustrated below:



Source: Sewa Pvt. Ltd.

## 4.2.2 Rat Trap Bond Brick Masonry

Rat Trap Bond is one of the brick bonding construction techniques in the walling system. In this type of brick bond techniques, the bricks are laid on edge with 1:6 cement mortar as shown in the figure.

- 1) Consumption of brick in Rat Trap Bond is reduced by 25-30 % (depending on the thickness of brick). Due to this reduction in number of bricks, the consumption of cement mortar is also reduced to 55% (45% cement and 50% sand is saved as compared to normal English Bond and Flemish Bond brick wall).
- 2) The bond acts as a good thermal insulator due to cavity in between. Plastering on the outer wall may not require due to the attractive appearance. CO<sub>2</sub> emission in Rat trap bond in 1m<sup>3</sup> brick work is  $820/27.5 \times 2.2 = 65.5$  kg of CO<sub>2</sub> against  $1236/27.5 \times 2.2 = 99$  kg of CO<sub>2</sub> in normal English Bond. General masonry specifications apply.

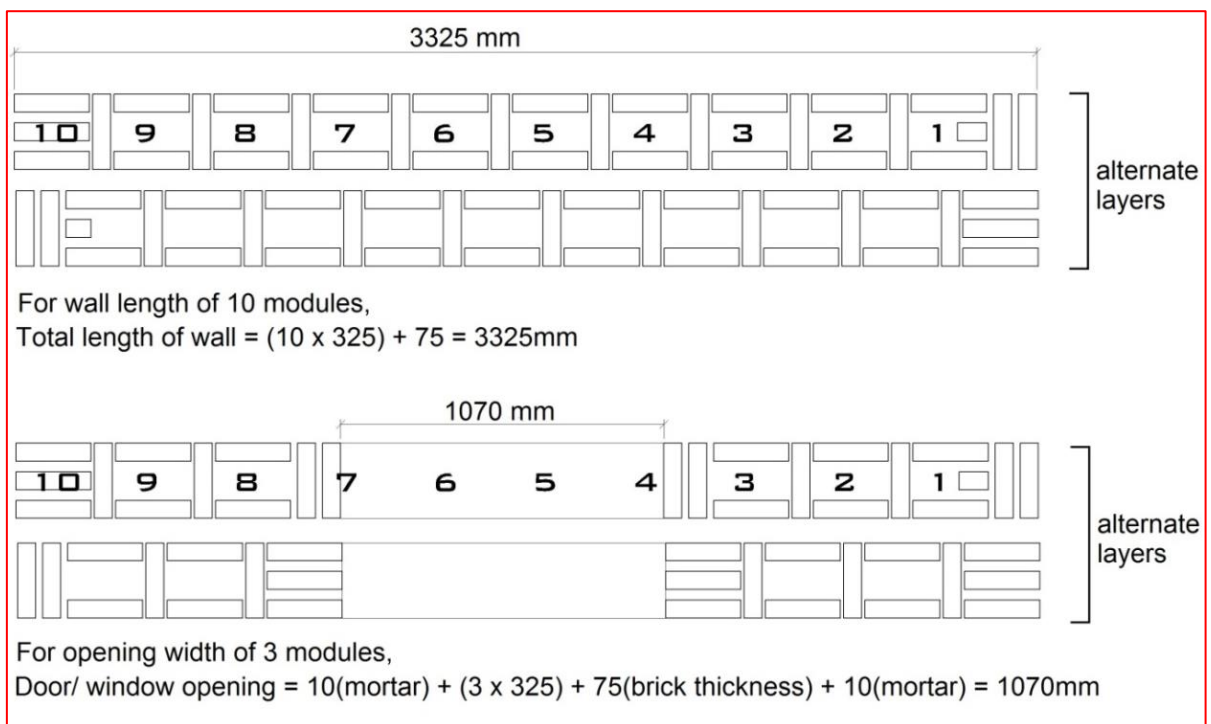

Source: Ministry of Rural Development, Government of India

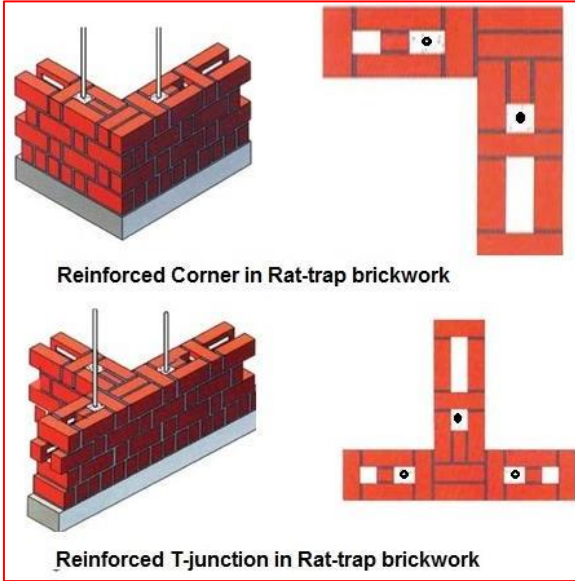

Source: MInenergy

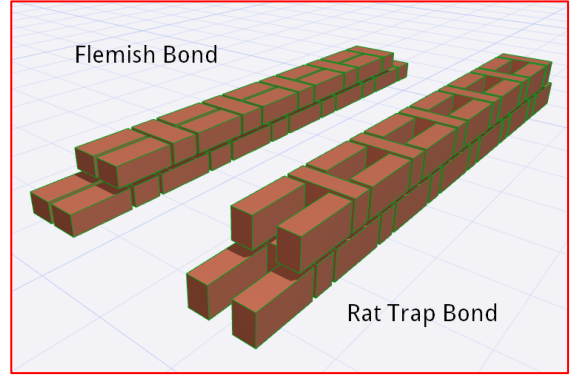

Source: btsquarepeg

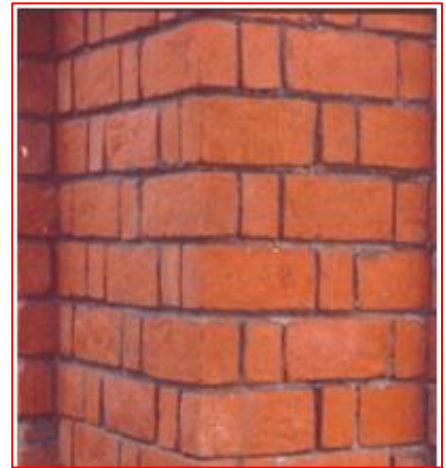

### 4.2.3 Compressed Stabilized Earthen Block (CSEB):

CSEB, is a type of manufactured construction material formed in a mechanical press that forms a compressed block out of an appropriate mix of fairly dry inorganic soil, non-expansive clay, aggregate, and sometimes a small amount of cement or lime as stabilizer.

#### Materials

i) **Soil:** Soil is the main ingredient of the CSEB. Soil characteristics and climatic conditions of an area shall be evaluated before manufacturing soil building blocks. The soil shall be much sandier than clayey. Top soil and organic soils shall not be used. The soil, however, shall contain a minimum quantity of silt and clay so as to facilitate cohesion. The proportion of gravel, sand, silt, and clay shall be determined through Sedimentation Test or sieve analysis. Further accuracy requires sieve analysis and hydrometric test. All soils are not suitable for every building need particularly CSEB. Good soil for CSEB shall contain the following proportion of the four components: gravel, sand, silt and clay. The ingredients shall be mixed thoroughly.

Composition of Good Soil for CSEB

Table 1:

Gravel	Sand	Silt	Clay
15%	50 %	15%	20 %

ii) **Water:** Water is one of the important elements in CSEB production. The quality and quantity of water has much effect on the strength of CSEB. Water for mixing and curing work shall not be salty or blackish and shall be clean drinking water, reasonably and free from objectionable quantities of silt and traces of oils, acid and injurious alkali, salts, organic matter and other deleterious material which will weaken the concrete. The pH value of water shall not be less than 6. Water shall be obtained from the sources approved by the Engineer. Sources of water shall be maintained at such a depth and the water shall be withdrawn in such a manner as to exclude silt, mud, grass or other foreign materials. Containers for transport, storage and handling of water shall be clean. Sand: Sand for use shall be natural sand. Sand shall be clean, well graded, hard, strong, durable and gritty particles free from injurious amounts of dust, clay, soft or flaky particles, shale, salts, organic matter, loam, mica or other deleterious substances and shall be approved by the Engineer. When the quality of fine aggregate is doubtful, it shall be tested for clay, organic impurities and other deleterious substances as laid down in I.S. 383-1970.

**iii) Cement:** Cement shall conform to I.S. 12269-1987. Ordinary Portland cement of grade 53 shall be used. Cement required for use shall be as fresh as possible and stored in such a manner as to prevent deterioration by dampness or moist atmosphere or intrusion of foreign matter. Any cement which has deteriorated cracked or which has been damaged shall not be used. When the quality of cement is doubtful, it shall be tested as laid down in I.S. 12269-1987. The weight of Ordinary Portland Cement shall be taken as 1440 kg. per cum. The measurement of proportion of cement should normally be on the bases of weight and each whole bag, undisturbed and sealed, weigh 50 kg.

**iv) Soil stabilizer:** The chemical admixtures such as lime, cement, and/or fly ash shall be used as a mean of chemically transforming unstable soils into structurally sound construction foundation. The selection of a stabilizer will depend upon the soil quality and the project requirements. Cement will be preferable for sandy soils and to achieve quickly a higher strength. Lime will be rather used for very clayey soil, but will take a longer time to harden and to give strong blocks.

**Classification:**

The CSEB shall be classified on the basis of average compressive strength and water absorption.

Table 4: Classes of CSEB

	Class A	Class B
Dry Compressive Strength (Mpa)	5-7	2-5
Wet Compressive Strength (Mpa)	2-3	1-2
Water Absorption(% by weight)	5-10	10-2

**General Quality:**

CSEB shall be molded from good soil (with gravel-15%, sand-50%, silt-15% and clay - 20%). CSEB shall be of uniform, regular in shape and size and shall have shapes having each two adjacent plane surfaces at true right angles. CSEB shall be free from cracks, chips, flaws, stones or lumps of any kind. They shall be free from salt which affect the mortar of the masonry. CSEB shall not show any sign of efflorescence either dry or subsequent to soaking in water. CSEB shall be sound, hard, homogeneous texture.

**Dimension:**

The standard size of CSEB made out of Aurum 3000 shall be are as follows:

Table 5: Dimensions of CSEB

Types	Length (mm)	Breadth (mm)	Height (mm)
-------	-------------	--------------	-------------



Plain full block	240	240	90
U block	240	240	90



**Source:** Ministry of Education, Science and Technology,

### **CSEB Production Procedure**

- i) Material Selection and Collection:** The basic materials required to produce compressed stabilized earth building blocks are soil, stabilizer, and water. Soils are found naturally but all soils are not suitable for CSEB Production. Some visual inspection and simple testing shall carry to select material sources. Topsoil shall be removed as it contains organic matters. Soil below the topsoil shall be collected in large quantity as per required and transferred to the site. Collection of soil can be done manually or with the help of excavator and tractor.
- ii) Pulverizing and Screening:** The materials' lumps shall pulverize to disintegrate manually or mechanically. Soil then shall screen in order to remove large size materials and also to get the soil of uniform size which helps for well mixing with sand and cement. Generally screening can be done with 10mm size mesh wire net but done with 2mm size mesh wire net for better performance while mixing.
- iii) Testing:** Laboratory analysis of the raw material is always necessary for large-scale production of compressed stabilized earth blocks. For small-scale production, however, it is not essential to employ sophisticated tests to establish the suitability of a soil. Simple field tests such as visual identification smell test, touch test, sedimentation test, adhesion test, washing test, Dry strength test, water retention test, consistency test, and cohesion test shall

be performed to identify the composition and quality of the soil sample. Among many tests, Sedimentation test shall be at least done to identify different composition of soil. Further accuracy requires sieve analysis and hydrometric test.

- iv) Proportioning:** Before starting production, tests shall perform to establish the right proportion of soil, stabilizer and water for the production of good quality blocks. The proportions of these materials and water shall then use throughout the production process. To ensure uniformity in the compressed stabilized earth blocks produced, the weight or volume of each material used in the block making process shall measure at the same physical state for subsequent batches of blocks. The volume of soil or stabilizer shall ideally measure in dry or slightly damp conditions. After establishing the exact proportion required of each material, it is advisable to build a measuring device for each material. The dimensions of each measuring box shall be such that their content, when full, is equivalent to the proportion which should be mixed with other materials measured in other boxes.
- v) Mixing:** In order to produce good quality blocks, it is very important that mixing be as thorough as possible. Dry materials shall be mixed first until they are of uniform color, then water is added, and mixing continued until a homogeneous mix is obtained. Mixing can be performed by hand on a hard surface, with spades, hoes, or shovels Water shall add a little at a time, sprinkled over the top of the mix from a watering can with a rose spray on the nozzle. The wet mix shall turn over many times with a spade. A little more water may then be added, and the whole mixture turned over again. This process shall repeat until all the water has been mixed in. Machine can use for mixing. It should have paddles or blades that move separately from the container. A concrete mixer shall not use for mixing the wet soil, since the latter will tend to stick on the sides of the rotating drum. Hand-mixing methods are often more satisfactory, more efficient, and cheaper than mechanical mixing, and are less likely to produce small balls of soil that are troublesome at the block moulding stage.
- vi) Molding:** Special precautions shall be taken during moulding in order to produce blocks of uniform size and shall be well compacted to achieve dense and compressed blocks. A machine, Aurum 3000, can be used for the production of CSEB which can produce 1000 blocks per day. The internal faces of the machine mould shall be moistening with a mould releasing agent (reject oil) in order to get well shaped and neat surfaced blocks.
- vii) Transporting and storing and curing CSEB:** The produced CSEB should be properly carried to the site for storing and curing. Proper handling shall be done during transportation. The site selected for storing shall be well levelled ground and protected from direct exposed to hot dry weather conditions which prevent block shrinkage and warping. It is done till the CSEB production completes. The curing should be done with portable water for a period of three weeks to achieve its maximum strength.



#### 4.2.4 Stone-Crete Block (SCB)

Stone-Crete blocks are made from the proportionate mix of cement, sand, aggregate and stone. These are made in molds made from either ply or metal.

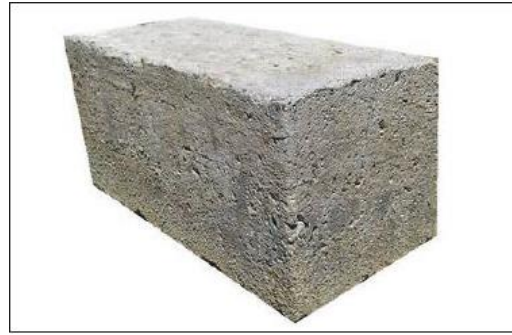

**Source:** Habitat for Humanity Nepal

**sizes:** Stone Crete blocks can be produced in the sizes 300x150x150 mm., 230x 150x150 mm., 150x150x150 mm.

#### Materials

1. cement
2. sand
3. aggregate
4. stone
5. water

#### Benefits of Stone-Crete Blocks

Stone-Crete blocks are made from the proportionate mix of cement, sand, aggregate and stone. These are made in moulds made from either ply or metal. Stone Crete blocks can be made from locally available materials (sand, aggregates, and stone) resulting in reduced transportation cost and environmental impact. The production of the stone Crete blocks in comparison to the production of bricks do not emit man-made CO<sub>2</sub> in the atmosphere. The block production creates very low amount of raw waste. They have damp proofing and fire-resistant properties. They are economically viable due to their size, and the number of units required for the construction. The blocks are long lasting and can withstand external forces due to its high compressive strength.

## **PART V: ENVIRONMENTAL IMPACT ASSESSMENT (EIA)**

## 5.1 Brief Environmental Studies (BES) for Building Construction

Brief Environmental Studies (BES) are required for building construction. The BES is a study that assesses the environmental impacts of a proposed building project. The study is conducted by a qualified environmental expert, and it includes an assessment of the following environmental factors:

**Air quality:** The BES will assess the impact of the building project on air quality. This includes assessing the emissions from construction activities, as well as the emissions from the building once it is completed.

**Water quality:** The BES will assess the impact of the building project on water quality. This includes assessing the impact of construction activities on water bodies, as well as the impact of the building on the quality of drinking water.

**Soil quality:** The BES will assess the impact of the building project on soil quality. This includes assessing the impact of construction activities on soil erosion, as well as the impact of the building on the quality of agricultural land.

**Noise pollution:** The BES will assess the impact of the building project on noise pollution. This includes assessing the impact of construction activities on noise levels, as well as the impact of the building on noise levels in the surrounding area.

**Ecological impacts:** The BES will assess the impact of the building project on the local ecology. This includes assessing the impact of construction activities on wildlife habitats, as well as the impact of the building on the overall ecology of the area.

The BES is an important tool for ensuring that building construction does not have negative environmental impacts. The study helps to identify potential environmental problems, and it provides recommendations for how to mitigate these problems.

Here are some of the key environmental considerations for building construction:

**The use of sustainable materials:** Building materials should be chosen that have a low environmental impact. This includes using materials that are locally sourced, recyclable, and biodegradable.

**The use of energy-efficient technologies:** Building technologies should be used that reduce energy consumption. This includes using solar panels, rainwater harvesting systems, and energy-efficient lighting.

**The design of the building:** The design of the building should take into account the local climate and environment. This includes designing the building to maximize natural ventilation and sunlight, and to minimize the use of artificial lighting and air conditioning.

**The construction process:** The construction process should be managed in a way that minimizes environmental impacts. This includes minimizing the use of water and fuel and disposing of construction waste properly. By taking these environmental considerations into account, building construction can be made more sustainable and environmentally friendly.

## **5.2 Initial Environment Examination (IEE) for Building Constructions**

An Initial Environmental Examination (IEE) is a type of environmental study that is required for some building constructions in Nepal. The IEE is a less comprehensive study than a full Environmental Impact Assessment (EIA), but it still provides an assessment of the potential environmental impacts of a proposed building project.

The IEE is conducted by a qualified environmental expert, and it includes an assessment of the following environmental factors:

**The location of the building:** The IEE will assess the impact of the building project on the surrounding environment. This includes assessing the impact of the building on air quality, water quality, soil quality, noise pollution, and ecological impacts.

**The size and type of the building:** The IEE will assess the impact of the building project on the environment based on the size and type of the building. For example, a large industrial building will have a different impact on the environment than a small residential building.

**The construction methods and materials:** The IEE will assess the impact of the construction methods and materials used in the building project. For example, the use of concrete will have a different impact on the environment than the use of wood.

**The operation and maintenance of the building:** The IEE will assess the impact of the operation and maintenance of the building on the environment. This includes assessing the impact of the building on air quality, water quality, and noise pollution.

The IEE is an important tool for ensuring that building construction does not have negative environmental impacts. The study helps to identify potential environmental problems, and it provides recommendations for how to mitigate these problems.

The IEE is required for building constructions that meet the following criteria:

- The building is located in a sensitive environmental area.
- The building is large or complex.
- The building uses hazardous materials.
- The building is likely to have a significant environmental impact.

## 5.3 Environment Impact Assessment (EIA) for Building Constructions

An Environmental Impact Assessment (EIA) is a study that assesses the potential environmental impacts of a proposed project. EIAs are required for all major development projects, including building constructions.

**The EIA is conducted by a qualified environmental expert, and it includes an assessment of the following environmental factors:**

**The location of the building:** The EIA will assess the impact of the building project on the surrounding environment. This includes assessing the impact of the building on air quality, water quality, soil quality, noise pollution, and ecological impacts.

**The size and type of the building:** The EIA will assess the impact of the building project on the environment based on the size and type of the building. For example, a large industrial building will have a different impact on the environment than a small residential building.

**The construction methods and materials:** The EIA will assess the impact of the construction methods and materials used in the building project. For example, the use of concrete will have a different impact on the environment than the use of wood.

**The operation and maintenance of the building:** The EIA will assess the impact of the operation and maintenance of the building on the environment. This includes assessing the impact of the building on air quality, water quality, and noise pollution.

The EIA is an important tool for ensuring that building construction in Nepal does not have negative environmental impacts. The study helps to identify potential environmental problems, and it provides recommendations for how to mitigate these problems.

The EIA is required for building constructions that meet the following criteria:

- The building is located in a sensitive environmental area.
- The building is large or complex.
- The building uses hazardous materials.
- The building is likely to have a significant environmental impact.

Here are some of the key environmental considerations for building construction:

**The use of sustainable materials:** Building materials should be chosen that have a low environmental impact. This includes using materials that are locally sourced, recyclable, and biodegradable.

**The use of energy-efficient technologies:** Building technologies should be used that reduce energy consumption. This includes using solar panels, rainwater harvesting systems, and energy-efficient lighting.

**The design of the building:** The design of the building should take into account the local climate and environment. This includes designing the building to maximize natural ventilation and sunlight, and to minimize the use of artificial lighting and air conditioning.

**The construction process:** The construction process should be managed in a way that minimizes environmental impacts. This includes minimizing the use of water and fuel, and disposing of construction waste properly.

By taking these environmental considerations into account, building construction can be made more sustainable and environmentally friendly.

### **Role of local governments for application of Brief Environmental Studies (BES), Initial Environment Examination (IEE) and Environmental Impact Assessment (EIA) to designing earthquake-risk-free buildings in Nepal**

Local governments play a crucial role in the application of Brief Environmental Studies (BES), Initial Environment Examination (IEE), and Environmental Impact Assessment (EIA) for designing earthquake-risk-free buildings. Their responsibilities include:

**Regulatory Framework:** Local governments are responsible for establishing and enforcing regulations and policies related to environmental assessments and building codes. They should develop guidelines that mandate the incorporation of BES, IEE, and EIA into the building design and approval process.

**Coordination and Oversight:** Local governments coordinate with relevant government agencies, experts, and stakeholders to ensure the proper implementation of BES, IEE, and EIA. They oversee the entire process, from conducting the assessments to reviewing reports and approving building permits.

**Capacity Building:** Local governments should invest in capacity building initiatives to enhance the knowledge and skills of their staff involved in the assessment and approval processes. This includes training personnel in environmental science, seismic risk assessment, and sustainable building practices.

**Collaboration with Experts:** Local governments collaborate with environmental experts, geologists, engineers, and other professionals to ensure accurate assessments and the implementation of appropriate measures. They should establish partnerships with academic institutions and research organizations to access expert knowledge and promote innovation in earthquake-resistant building design.

**Public Engagement:** Local governments should facilitate public participation in the BES, IEE, and EIA processes. They can conduct public hearings, workshops, and consultations to gather community input, address concerns, and ensure transparency. Public awareness campaigns can also be organized to educate citizens about the importance of earthquake-resistant buildings and environmental sustainability.

**Compliance and Monitoring:** Local governments are responsible for monitoring compliance with the recommended mitigation measures outlined in the assessments. They should conduct regular site inspections and audits during the construction phase to ensure that earthquake-resistant design principles and environmental safeguards are followed.

**Enforcement and Penalties:** Local governments must have mechanisms in place to enforce compliance with environmental regulations and building codes. They should impose penalties or sanctions on individuals or organizations that violate the prescribed guidelines or fail to implement recommended measures.

**Review and Updating of Policies:** Local governments should periodically review and update their policies, guidelines, and building codes to align with evolving scientific knowledge, best practices, and changing environmental conditions. This ensures that the BES, IEE, and EIA processes remain effective and up-to-date in addressing earthquake risks and environmental concerns.

By fulfilling these roles, local governments can effectively integrate BES, IEE, and EIA into the design of earthquake-risk-free buildings, promoting sustainable development and enhancing the resilience of the built environment.

### **How local governments can apply Brief Environmental Studies (BES), Initial Environment Examination (IEE) and Environmental Impact Assessment (EIA) to designing earthquake-risk-free buildings?**

Designing earthquake-risk-free buildings requires careful consideration of environmental factors and conducting assessments to ensure the safety and sustainability of the structures. The local government can apply Brief Environmental Studies (BES), Initial Environment Examination (IEE), and Environmental Impact Assessment (EIA) in the following ways:

#### **Brief Environmental Studies (BES):**

- Conduct a BES to identify the potential environmental impacts of constructing earthquake-resistant buildings. This study can assess the local topography, geology, hydrology, and other relevant factors.
- Evaluate the impact of construction activities on the natural environment, including soil erosion, water pollution, and deforestation.
- Identify suitable building sites based on environmental factors, such as avoiding landslide-prone areas or areas with high seismic activity.



### **Initial Environment Examination (IEE):**

- Conduct an IEE to assess the potential environmental impacts of specific building projects. This examination focuses on smaller-scale projects and helps identify the mitigation measures required.
- Evaluate the potential impacts of building materials, construction techniques, and waste management systems on the environment.
- Propose measures to minimize adverse impacts, such as using locally available and sustainable construction materials, implementing efficient waste management practices, and minimizing energy consumption.

### **Environmental Impact Assessment (EIA):**

- Perform an EIA for larger-scale building projects that may have significant environmental impacts. This assessment provides a comprehensive analysis of the potential consequences of the project.
- Assess the project's impact on air quality, water resources, biodiversity, and local communities.
- Develop and implement mitigation measures, such as incorporating earthquake-resistant design principles, adopting energy-efficient technologies, and promoting sustainable construction practices.
- Engage stakeholders, including local communities and environmental experts, in the EIA process to ensure transparency and gather valuable input.

Additionally, the local government should ensure that the BES, IEE, and EIA processes are aligned with relevant laws, regulations, and guidelines for environmental assessments. They should also encourage collaboration between government agencies, engineering professionals, and environmental experts to incorporate seismic resilience and sustainability into building design and construction practices.

By integrating BES, IEE, and EIA into the process of designing earthquake-risk-free buildings, the local government can promote environmentally sound practices while prioritizing the safety and resilience of structures.

### **The importance of involving local communities in the BES, IEE and EIA process and obtaining their input on the design and construction of earthquake-resistant buildings.**

Involving local communities in the BES, IEE, and EIA process and obtaining their input on the design and construction of earthquake-resistant buildings is crucial for several reasons:

**Local Knowledge and Experience:** Local communities possess valuable knowledge and experience about their specific environment, including seismic activity, geological features, and local vulnerabilities. Their input can provide insights that might not be captured through technical assessments alone. Engaging them in the process allows for the incorporation of this valuable local knowledge into the design and construction of earthquake-resistant buildings.

**Enhanced Decision-making:** Involving local communities ensures that the decision-making process is more inclusive and democratic. It allows affected communities to have a say in the development projects that directly impact their lives, homes, and surroundings. Their input can influence the design choices, construction techniques, and mitigation measures, resulting in solutions that are more socially acceptable and sustainable.

**Community Ownership and Empowerment:** By involving local communities in the BES, IEE, and EIA processes, they develop a sense of ownership and empowerment over the outcomes. This fosters a stronger commitment to the project and increases the likelihood of successful implementation. When communities are actively engaged, they become stakeholders in the process and are more likely to support and maintain earthquake-resistant buildings over the long term.

**Cultural and Social Considerations:** Local communities often have unique cultural, social, and historical contexts that should be taken into account when designing earthquake-resistant buildings. Involving them in the process allows for the integration of these considerations into the design, ensuring that the buildings are not only safe but also culturally appropriate and sensitive to local values.

**Trust and Transparency:** Engaging local communities in the BES, IEE, and EIA processes fosters trust and transparency between the government, experts, and the community. It demonstrates a commitment to open dialogue, active participation, and mutual respect. This helps build trust in the decision-making process and increases the likelihood of successful implementation of earthquake-resistant building projects.

**Social and Economic Development:** The involvement of local communities in the design and construction of earthquake-resistant buildings can have positive social and economic impacts. It can create opportunities for local employment, skill development, and knowledge transfer. In addition, community engagement can lead to the identification of innovative solutions that align with the community's needs, aspirations, and development priorities.

Overall, involving local communities in the BES, IEE, and EIA processes and obtaining their input on the design and construction of earthquake-resistant buildings ensures that the outcomes are more comprehensive, contextually appropriate, and sustainable. It strengthens community resilience, fosters ownership, and promotes social and economic development in earthquake-prone areas.

## Appendices

### Appendix I: The Building Act, 1999

#### The Building Act, 1999

#### (An Unofficial Translation)

##### Amending Act

##### Date of Publication

Building (First Amendment) Act, 2007

August 31, 2007

#### Act No. 2 of the year 2055

#### An Act to provide for regulating building construction activities

Preamble: Whereas it is expedient to make necessary legal provisions with regard to regulating building construction activities in order for protecting buildings from earthquake, fire and other natural calamities to the extent possible;

Be it enacted by Parliament in the 27<sup>th</sup> year of the reign of His Majesty the King Birendra Bir Bikram Shahdev.

1. Short Title and Commencement: (1) This Act may be cited as “(the) Building Act, 1999.”  
(2) This Act shall come into force from the date and in the area as may be appointed by Government of Nepal having published a notification in the Nepal Gazette.\*
2. Definition: Unless the subject or context requires otherwise, in this Act, -
  - (a) “Building” means a residential, industrial or commercial building, office, city hall, hospital, cold storage, go down, or any physical structure constructed for any other use and the word also includes any part of such a structure.
  - (b) “Building Code” means the National Building Code approved by Government of Nepal pursuant to sub-Section (2) of Section 9.
  - (c) “Building construction” means construction of a new building, reconstruction of a new building having removed the old building, adding storeys, *changing the outer look (Mohada ferne)* or adding or removing the windows, doors, balcony, *kausi, dalan* or the acts relating thereto.

---

\* The Act came into force in the prescribed areas to be effective from February 23, 2006 (Nepal Gazette dated February 23, 2006).

- (d) “Committee” means the Building Construction Management Strengthening Committee formed pursuant to Section 3.
- (e) “Drawing” means all the sketches, statements and other documents relating to building construction.
- (f) “Municipality” means a Municipality formed according to a law in force and the word also includes a Metropolitan city and sub-metropolitan city.
- (g) “Government office” means a Ministry, secretariat, Department and an Office of Government of Nepal and the word also includes a Commission, Council and Board constituted under a law in force.
- (h) “Urban Development Office” means the Urban Development and Building Construction Division Office.

3. Formation of the Building Construction Management Strengthening Committee: (1) Government of Nepal shall form a Building Construction Management Strengthening Committee for strengthening the provisions related to building construction.

(2) The Committee referred to in sub-Section (1) shall comprise of the following Chairperson and members: -

- (a) Secretary, Ministry of Physical Planning and works -Chairperson
- (b) Representative, National Planning Commission -Member
- (c) Representative, Ministry of Law, Justice and Parliamentary Affairs -Member
- (d) Member-Secretary, Nepal Council of Standards -Member
- (e) Dean, Institute of Engineering -Member
- (f) Joint Secretary, Ministry of Local Development -Member
- (g) Chief, the Research Centre for Applied Science and Technology -Member
- (h) Three experts in maximum nominated by Government of Nepal from among persons having special knowledge on building construction -Members
- (i) \*Director General, Department of Urban Development and Building Construction -Member-Secretary

---

\* Amended by the First Amendment.

♦(3) .....

(4) The Committee may, if it deems necessary, invite to take part the concerned native or foreign expert or any other person in the meeting of the Committee as an observer.

(5) The \*Department of Urban Development and Building Construction shall carry out functions as the secretariat of the Committee.

4. Functions, Duties and Powers of the Committee: In addition to those referred to elsewhere in this Act, the functions, duties and powers of the Committee shall be as follows: -

(a) To make necessary legal provisions with regard to regulating building construction activities in order to protect buildings from earthquake, fire and other natural calamities to the extent possible;

(b) To formulate building code for regulating building construction activities and submit it to Government of Nepal for approval;

(c) To carry out or cause to be carried out studies and research works necessary for bringing timely changes in building code and developing procedures and technology for building construction;

(d) \*To cause to be conducted inquiry into whether or not drawings have been approved according to the standard specified in the building code;

(e) To make recommendations to the Nepal Council of Standards to determine standards of native and foreign construction materials relating to building construction;

(f) To organize meetings and seminars involving technical experts and staff of the concerned agencies for bringing timely changes into the problems arisen in the implementation of the building code;

(g) To disseminate information to general public with regard to utilization of the building code;

(h) To carry out or caused to be carried out other acts necessary for executing the objectives of this Act.

5. Meetings and Decisions of the Committee: (1) Meeting of the Committee shall be convened on the date time and place prescribed by the Chairperson of the Committee as may be necessary.

(2) The Member-secretary of the Committee shall have to inform all members along with agenda of the meeting before at least three days of from the date of meeting.

---

♦ Repealed by the First Amendment.

- (3) The presence of fifty percent of the total members of the Committee shall constitute the quorum of the Committee.
- (4) The chairperson of the Committee, and in his/her absence, the member selected by the members from among themselves, shall preside over a meeting of the Committee.
- (5) The opinion of the majority in a meeting of the Committee shall be valid and in case of equal division of votes, the person presiding over the meeting shall exercise the casting vote.
- (6) The name of each of the members present in a meeting, the agenda of discussion and the decisions taken in meetings of the Committee shall be written down in a minute and get it signed by all members present.
- (7) The Member-Secretary of the Committee shall authenticate decisions of the Committee.
- (8) Other procedures relating to meetings of the Committee shall be as prescribed by the Committee.
6. Sub-Committee may be formed: (1) The Committee may form various sub-committees as may be necessary comprising of the concerned experts for carrying out or causing to be carried out any act it has to perform.
- (2) The functions, duties and powers of the sub-committees formed pursuant to sub-Section (1) shall be as specified by the Committee.
7. Meeting Allowances: The members of the Committee and sub-committees formed pursuant to Section 6 and the invitee persons shall be entitled to receive meeting allowance as specified by Government of Nepal for taking part in a meeting.
8. \*Classification of Buildings: For the purpose of formulation and implementation of the building code, the buildings shall be classified in the four classes as follows: -
- a) Class “A”: The most modern buildings to be constructed based on the international state-of-the-art having followed the building codes observed in the developed nations;
  - b) Class “B”: The buildings having the plinth area of more than 1000 square feet, having more than three storeys including the ground floor or having a structural span of more than four and half (4.5) meters;
  - c) Class “C”: The buildings having the plinth area up to 1000 square feet, having more than three storeys including the ground floor or having a structural span of more than four and half (4.5) meters;

---

\* Amended by the First Amendment.

- d) Class “D”: Small houses or sheds of up to two storeys constructed having used raw or burnt bricks, stone, bamboo, hay and other than those referred to in clauses (a), (b) and (c).
9. Building Code to be got approved: (1) The Committee shall prepare building code also on the basis of the building classification referred to in Section 8 and submit it to the Government of Nepal, Ministry of Physical Planning and works for approval.
- (2) The building code submitted pursuant to sub-Section (1) shall come into force upon its approval by Government of Nepal, Ministry of Physical Planning and works.
10. Building to be constructed as per building code: While constructing building by any person, organization or government agency, the building shall have to be constructed according to the standard prescribed in the building code. <sup>+</sup>While constructing a building in such a manner, the building shall be constructed under the guidance of the designer or his/her representative, engineer or architect of at least the same level of the designer, engineer or architect who has approved the drawing or design of such a building.
11. \*Drawing/Design of the buildings get to be approved: (1) The person, organization or government agency willing to construct a building of classes “A”, “B” or “C” referred to in Section 8 within a Municipal area shall have to submit the design along with the drawings to the concerned municipality office for approval.
- (2) The person, organization or government agency willing to construct a building of classes “A” and “B” referred to in Section 8 outside a Municipal area shall prepare the drawing / design and get it approved from the concerned Urban Development Office.
- Provided that in case of the building of class “C”, the drawing as per the Building Code shall have to be produced while applying for approval of drawing according to the laws in force for the time being.
- (3) The certification that the drawing and design submitted pursuant to sub-section (1) or (2) is according to the building code shall be made from the following persons: -
- a) From the concerned designer in case of the class “A” building referred to in section 8;
  - b) From a civil engineer or architect registered with the Nepal Engineering Council in case of the class “B” building referred to in section 8;

---

<sup>+</sup> Inserted by the First Amendment.

<sup>\*</sup> Amended by the First Amendment.



- c) From a person having passed at least the proficiency certificate level in the civil engineering or architect subject from a recognized academic institute in case of the class “C” building referred to in section 8;

12. Drawing not be approved against the norms: (1) A Municipality shall not approve drawing against the norms set out in the Building code.

(2) Department of Urban Development & Building Construction has the authority to investigate whether the concerned municipality's approval is in compliance to the Building Code or not.

(3) DUDBC shall report to the committee in case any municipality has approved the drawing which does not comply with the Building Code while making investigation as per Sub-section (2)

(4) The committee shall give directives to the concerned municipality for making approvals in compliance with Building Code while making decision to the complains as per Sub-section (3)

(5) The concerned municipality shall make its approval procedure in compliance with the decision as per Sub-section (4)

13. Building Construction may be monitored: (1) The Urban Development Office may monitor as to whether or not any person, organization or government agency has observed the standards referred to in the building code while constructing a building, in the area outside municipal area whereas municipality is responsible within its area.

(2) While monitoring pursuant to sub-Section (1), in case the Urban Development Office or municipality find that construction of a building is not in accordance with the norms set out in the building code, it may give necessary directives to the concerned person, organization or government agency and it shall be the duty of the concerned person, organization or government agency to abide by such directives.

14. Punishment: (1) In case anyone constructs a building without getting the drawing approved under this Act, the Urban Development Office shall immediately issue an order to suspend such construction work, in the area outside municipality whereas the concerned municipality shall do the same within its area.

(2) In case anyone constructs a building against the approved drawing or the standards set out in the building code, the Urban Development Office or concerned municipality shall issue an order to demolish the whole or a part of such a building and impose a fine on the concerned person, organization committing such an act not exceeding fifty thousand rupees in case of construction of class “B” building.

(3) In case the Urban Development Office or municipality has issued an order to demolish the whole or a part of a building pursuant to sub-Section (2), the Office shall also have to request in writing to the concerned offices for suspending the transfer of title or mortgage of such property or for not supplying water, electricity or connecting telephone to such constructed building or for disconnecting the supply of water, electricity or telephone, if supplied or connected, and the concerned offices shall also have to do as requested.

15. Appeal: Whoever does not satisfy with an order issued by the Urban Development Office or municipality pursuant to sub-Section (2) of Section 14 may, within thirty-five days from the date of receipt of such an order, file an appeal to the concerned Appellate Court.

16. Dismantling building and recovering the accrued expenses: (1) In case an order has been issued to demolish the whole or a part of a building pursuant to sub-Section (2) of Section 14, the concerned person, organization or government agency shall have to demolish the building or any part thereof within thirty-five days from the date of decision from the Appellate Court to the effect of demolishing the whole or a part of a building, if an appeal is filed pursuant to Section 15, and within thirty-five days of the expiry of the time limit to file the appeal, if no appeal is filed.

(2) In case the concerned person, organization or government agency does not demolish the building or any part thereof within the period referred to in sub-Section (1), the Urban Development Office may itself demolish the building or any part thereof and the costs incurred while demolishing in such a manner shall be recovered as a government due from the concerned person, organization or government agency.

(3) While demolishing a building or any part thereof by the Urban Development Office or municipality itself under this Act, it shall have to demolish in the presence of the chairperson of the Village Development Committee or of the concerned Ward. The Urban Development Office or municipality shall not be liable in case more than the required portion of a building is demolished despite of its best efforts and the concerned person shall not be entitled to claim a compensation for the loss incurred due to the demolishing of more than the required portion.

(4) While demolishing work done by Urban Development Office or municipality, the demolishing shall be done in presence of at least four local inhabitants in case concerning chairperson of Ward or Village Development Committee is not available.

17. Assistance to be rendered: It shall be the duty of the concerned Municipality, Village Development Committee and local administration to render necessary assistance to the

- Urban Development Office in connection with execution of an order issued by the Urban Development Office pursuant to sub-Section (2) of Section 16.
18. Notice to be published: (1) Government of Nepal shall have to publish for information of general public the building code in the Nepal gazette.
- (2) After the notification, any person has a right to get copy of Building Code from the Urban Development Office after paying prescribed cost.
19. Delegation of Powers: The Committee may delegate some of its powers to the members of the Committee or sub-Committee formed pursuant to Section 6, to a government office, municipality, Urban Development Office or any staff of officer rank as may be necessary.
20. Directives may be issued: (1) Government of Nepal may issue necessary directive to the Committee with regard to formulation and implementation of the building code.
- (2) It shall be the duty of the Committee to abide by the directive issued by Government of Nepal pursuant to sub-Section (1).
21. To be as per this Act: It shall be in accordance with this Act on the matters provided for in this Act and it shall be according to the laws in force in the rest of the matters.
22. Power to Frame Rules: Government of Nepal may frame necessary Rules in order to execute the objectives of this Act.

The Date of the Royal Assent

July 2, 1998

## Appendix II: The Building Regulation, 2009

### The Building Regulation, 2009

(An unofficial translation)

Government of Nepal has, in exercise of the powers conferred by Section 22 of the Building Act, 1999, framed the following Rules.

1. Short Name and Commencement: (1) This Regulation may be cited as “(the) Building Regulation.”  
(2) This Regulation shall come into force at once.
2. Definition: Unless the subject or context otherwise requires, in this Regulation, -
  - (a) “Act” means the Building Act, 1999.
  - (b) “Village Development Committee” means a Village Development Committee where the Building Act has been enforced.
3. Approval to be obtained prior to construction of a building: (1) Any person, organization or government agency willing to construct a building of the “A” “B” or “C” class referred to in sub-section (1) of Section 11 of the Act shall, while submitting application for approval of the drawing to a Municipality in the format referred to in schedule-1, have to submit the design as well.  
(2) Any person, organization or government agency willing to construct a building of the “A” or “B” class referred to in sub-section (2) of Section 11 of the Act shall, while submitting application for approval of the drawing to a Municipality in the format referred to in schedule-1, have to submit the structure and design as well and any person, organization or government agency willing to construct a building of the “C” class shall submit the drawing for approval to the Urban Development Office of the concerned district in the format referred to in schedule-1.  
(3) The Urban Development Office shall conduct necessary inquiry on an application received pursuant to sub-rule (2) and in case an additional document is required while conducting an inquiry in such a manner, it may ask the applicant to produce such additional document.

(4) While conducting an inquiry, in case the content of the applicant is found to be reasonable, the Urban Development Office shall approve the drawing or design of the building within 30 days from the date of submission of the application having specified the terms and conditions to be fulfilled while constructing the building.

4. Qualification of Expert: Government of Nepal shall, while nominating the member pursuant to clause (i) of subsection (2) of Section 3 of the Act, nominate from amongst the persons having met the following qualifications: -
  - (a) Having obtained at least a post-graduation degree in architecture or civil engineering subject and having had the experience of at least ten years in the acts relating to construction of a building referred to in clause (a) or (b) of section 8 of the Act; or
  - (b) Having obtained at least a Bachelor's degree in architecture or civil engineering subject and having had the experience of at least 15 years in the acts relating to construction of a building referred to in clause (a) or (b) of section 8 of the Act.
5. Fee for Copy of Building Code: The person willing to obtain a copy of the Building Code may obtain a copy thereof from the Urban Development Committee having paid the fee referred to in Schedule-2.
6. Change or Alteration in Schedules: Government of Nepal may, having published a notification in the Nepal gazette, bring necessary change or alteration in the schedules.

Shchedule-1

(Related to Sub-rules (1) and (2) of Rule 3)

APPLICATION FORM

.....Office,

.....

It is hereby requested for approval/advance design consent for constructing a building of class.....on the following land enclosing herewith the following drawing and documents:

**Site of the building construction:**

.....District.....Municipality/VDC.....ward.....map sheet No.....Plot No.....

Name of the applicant:

Address:

Phone No.

Signature of the applicant:

Date

Tick (√) on the class of the building used for the purpose of design pursuant to Section 8 of the Building Act, 1999.

- (a) "A" Class
- (b) "B" class
- (c) "C" class

Documents attached

1) Nos. of Architectural drawing sheets:

<b>S.No.</b>	<b>Drawings</b>	<b>No. of Sheets</b>
1.	Floor plans	
2.	Elevations	
3.	Two sections-Longitudinal Section and Cross Section (One of the section should be through staircase).	
4.	Site plan	
5.	Elevation of Doors and windows showing its openings and sizes.	
6.	Staircase Details.	
7.	Ramp Detail	
8.	Others (if any)	

2) Nos. of Structural drawing sheets:

<b>S.No.</b>	<b>Drawings for frame structure</b>	<b>No. of Sheets</b>
1.	Column Reinforcement for critical column (indicate position of the column in structure)	
2.	Critical beam reinforcement (indicate position)	
3.	Slab reinforcement	
4.	Staircase reinforcement	
5.	Trench plan and toe wall detail	

6.	Critical foundation detail (indicate position)	
7.	Ductile detailing of Beam and column joint	
8.	Others (if any)	
<b>S.No.</b>	<b>Drawings for Load Bearing Buildings</b>	<b>No. of Sheets</b>
1.	Architectural plan of each floor showing vertical steel reinforcement at critical sections.	
2.	Trench plan and foundation details	
3.	Slab reinforcement	
4.	Wall cross section	
5.	Others (if any)	

3) Nos. of Sanitary drawing sheets (only for Classes “A” and “B” buildings):

<b>S.No.</b>	<b>Drawings</b>	<b>No. of Sheets</b>
1.	Toilet detail plan (each floor)	
2.	Roof plan	
3.	Site plan	
4.	Plans of Underground water tank, Septic tank, Soak pit and Manhole	
5.	Isometric drawing (flow diagram chart)	
6.	Section (toilet with duct detail)	
7.	Drainage detail	
8.	Firefighting system.	
9.	Others (if any)	

4) Nos. of Electricity drawing sheets (only for Classes “A” and “B” buildings):

<b>S.No.</b>	<b>Drawings</b>	<b>No. of Sheets</b>
1.	Layout	
2.	Wiring	
3.	Schematic	
4.	Others (if any)	



- 5) Cadastral survey maps
- 6) Agreement entered into with technical consultant for engaging in the construction of the building as required pursuant to sub-section (3) of sections 10 and 11 of the Act.
- 7) Technical details forms: -
  - a) Related to Architectural design
  - b) Related to Structural design
  - c) Related to Sanitary design (only for Classes “A” and “B” buildings)
  - d) Related to Electricity designs (only for Classes “A” and “B” buildings)

Note:

- 1) In case of scale, all drawings must be 1:100 or 1” =8’ and the details must not be smaller than 1:50 or 1” =4’. In case of the site plan, it must be 1:100 or 1” =8’ up to one *ropani* and 1:200 or 1” =16’ in case of more than that.
- 2) If site inspection is required while approving the design, the site inspection must cause to be carried out.
- 3) In the case of classes “A” and “B”, form A, B, C and D of technical detail form No. 1 must be filled in.
- 4) In the case of class “C”, Form A of the technical detail form No. 1 and structural design requirements of technical detail form No. 2 must be filled in.
- 5) In case of any confusion as to the implementation of schedule 1, it shall be according to the decision of the committee.

Technical Detail Form No. 1

For Class "A" and " B" Buildings

**(A) NBC Code 206: 2003 - Architectural Design Requirements.**

(To be filled by concerned Architect or Consultant)

Type of Building.....

<b>Building Elements</b>	<b>As per Submitted Design</b>	<b>Remarks</b>
<b>1.0 Staircase</b>		
1.1 Min. tread width of staircase	..... mm excluding nosing	
1.2 Riser height of staircase	....mm	
1.3 Clear width of staircase for		
a) Hospital	....mm	
b) Auditorium		
- below 500 capacity		
- Above 500 capacity		
c) Others	.....mm	
1.4 Height of handrail	....mm	
1.5 Max. no of riser in one Single flight	.....Nos.	
1.6 Max. head room under staircase from the nosing of the tread	.....mm	
<b>2.0 Exit</b>		
2.1 Max. travel distance to exit point in each floor	....mm	
2.2 Min. width of exit door including frame	....mm	
2.2Min. height of exit door including frame	....mm	
2.3 Shutter opening of exit door to staircase & public Passage	Inside/Outside	
2.4 Total width of exit door	.....mm	
<b>3.0 Light and Ventilation</b>		
3.1 Min. opening area of window for lighting largest habitable room from external wall	.....sq. m.	

3.2 Min. opening area of natural ventilator for largest habitable room from external wall	.....sq. m.	
3.3 Min. size of ventilator for water closets and bathroom	.....sq. m.	
<b>4.0 Lifts</b>		
4.1 Total height of building	.....mm	
4.2 Provision of lift.	Yes/No	
4.3 No. of lift per bank	.....nos.	
<b>5.0 Requirement for the physically disabled</b>		
5.1 Is there a provision of separate entrance for disable people next to the primary entrance of a building	Yes/No	
5.2 Max. gradient for wheel chair ramp at entrance of building		
5.3 Min. width of wheelchair ramp at entrance of building.	.....mm	
<b>6.0 Parapet heights</b>		
6.1 The height of parapet wall & balcony handrail	.....mm	

Technical Detail Form No. 1

**(B) NBC 208: 2003- Sanitary and Plumbing Design Requirements**

(To be filled by concerned Engineer or Consultant)

Description	Design Capacity	Water consumption per capita per day as per submitted design	Water Storage Capacity	Remarks
<b>Underground Water Tank.</b>				
<b>1. Type of building</b>				
1.2) Auditorium	..... Nos.	..... Litres		
A.1.2) Hospital including laundry per bed				
a) Number of beds < 100 bed	.....Bed.	..... Litres.		
b) Number of beds > 100 bed	..... Bed.	.....Litres.		
1.3) Office building	.....Nos.	.....Litres.		
<b>2. Overhead water tank for Lavatory</b>				
a) Auditorium/Office Building	....(nos of w.c).	..... Litres.		
b) Hospital	....(nos. of urinal.)	.....Litres.		
	...(nos of w.c).	....Litres.		
Description	Design Capacity	Fixtures provided as per submitted design	Total	Remarks

<b>2.1 Fire Hydrant System. Hospital/ Auditorium (Indoor)</b>				
2.2) No of floors	....Nos. of floor	....Nos. of wet risers		
2.3) Floor area	M <sup>2</sup>	.... Nos. of wet risers		
2.4) Capacity of wet riser for underground water tank	-	.....Litres.		
<b>2.2 Type of buildings</b>				
Office building				
<b>Gents Toilet:</b> Nos of users--.....				
a) Water closet	-	.....Nos.		
b) Urinal	-	.....Nos.		
c) Basin	-	.....Nos.		
<b>Ladies Toilet:- Nos of users--.....</b>				
a) Water closet	-	.....Nos.		
<b>Auditorium</b>				
<b>Public toilet (Gents Toilet): Nos of users--.....</b>				
a) Water closet	-	.....Nos.		
b) Urinal	-	.....Nos.		
c) Basin	-	.....Nos.		
<b>Ladies Toilet:- Nos of users--....</b>				
a) Water closet	-	.....Nos.		
<b>Staff toilet (Ladies/Gents Toilet): Nos. of users--.....</b>				
a) Water closet	-	.....Nos.		
<b>Hospital indoor patient ward (For Ladies and Gents Toilet):- Nos. of users--.....</b>				
a) Water closet	-	.....Nos.		
b) Wash basin	-	.....Nos.		
c) Bath (Shower)	-	....Nos.		
d) Cleaner sink (Kitchen sink)	-	.....Nos.		

Technical Detail Form No. 1

**(C) NBC 207: 2003-- Electrical Design Requirements**

(To be filled by concerned Engineer or Consultant)

<b>S.No.</b>	<b>Electrical Elements</b>	<b>As per Submitted Design</b>
<b>1. Rating and sizes</b>		
1.1.	Minimum size (sq. mm.) of copper cable for light circuit	
1.2	Minimum size (sq. mm.) of copper cable for power circuit	
1.3	Wattage of ordinary power socket (2 pin) estimated as	
1.4	Wattage of power socket outlet (3pin) estimated as	
1.5	Wall thickness of cast iron switch or regulator boxes	
1.6	Wall thickness of mild steel sheet switch or regulator boxes for up to 20cm.x 30cm.	
1.7	Wall thickness of mild steel sheet switch or regulator boxes for above 20cm.x 30cm.	
1.8	Depth of the switch or regulator boxes	
<b>2. Maximum number of cables in a conduit</b>		
2.1	No. of 2.5 sq.mm. cross-sectional area cable in 20mm. dia conduit	
2.2	No. of 4 sq.mm. cross-sectional area cable in 20mm. dia conduit	
2.3	No. of 6 sq.mm. cross-sectional area cable in 20mm. dia conduit	
2.4	No. of 2.5 sq.mm. cross-sectional area cable in 25mm. dia conduit	
2.5	No. of 4 sq.mm. cross-sectional area cable in 25mm. dia conduit	
2.6	No. of 6 sq.mm. cross-sectional area cable in 25mm. dia conduit	
2.7	No. of 2.5 sq.mm. cross-sectional area cable in 32mm. dia conduit	
2.8	No. of 4 sq.mm. cross-sectional area cable in 32mm. dia conduit	
2.9	No. of 6 sq.mm. cross-sectional area cable in 32mm. dia conduit	
<b>3. Earthing</b>		
3.1	The value of any earth system resistance unless otherwise specified	

3.2	Diameter of rod electrodes of steel or galvanized iron	
3.3	Diameter of rod electrodes of copper	
3.4	Internal diameter of pipe electrodes of galvanized iron or steel	
3.5	Internal diameter of pipe electrodes of cast iron	
3.6	The length of the rod & pipe electrodes	
3.7	Thickness of plate electrodes of galvanized iron or steel	
3.8	Thickness of plate electrodes of copper	
3.9	Size of plate electrodes of galvanized iron or steel or copper	
3.10	Depth of the top edge of plate electrodes buried from ground	

#### 4. Testing

4.1	Insulation resistance (Mohm) between earth and the whole system of conductor or any section thereof	
4.2	Insulation resistance (Mohm) between the metallic case and all live part of each rheostat, appliance and sign when they are disconnected,	
4.3	Insulation resistance (Mohm) between all the conductors connected to one pole or phase conductor and all the conductor connected to the middle wire or to the neutral or to the other pole of the phase conductor	
4.4	The applied dc voltage (Volt) of measuring	
4.5	Each switch is placed in phase or neutral?	

#### Note:

1. When substation and external electrical works are required, designer must comply NBC 207: 2003 or/ a relevant international electrical codes.
2. Designer is advised to consider lightning protection designated by international electrical codes.



Technical Detail Form No. 1

**(D) NBC 000: 1994 to NBC 114: 1994 Structural Design Requirements**

(To be filled by concerned Engineer or Consultant)

S.N.	Description	As per submitted design	Remarks
<b>1. General:</b>			
	Number of Storey		
	Total height of structure		
	Structure system	<input type="checkbox"/> Frame <input type="checkbox"/> Load bearing <input type="checkbox"/> Other	
	If Computer Aided Design (CAD) is used, please state the name of the package		
<b>2. Requirements of NEPAL NATIONAL BUILDING CODE (NBC)</b>			
<b>2.1 NBC-000-1994 Requirements for State-of-the Art Design: An Introduction</b>			
	Level of design:	<input type="checkbox"/> International State-of-the-art <input type="checkbox"/> Professionally Engineered Structures <input type="checkbox"/> Mandatory Rule of thumb <input type="checkbox"/> Guidelines to rural building	
<b>2.2 NBC 101: 1994 Materials Specifications</b>			
	Tick the listed materials that will be used in the construction	<input type="checkbox"/> Cement <input type="checkbox"/> Coarse Aggregates <input type="checkbox"/> Fine Aggregates (Sand) <input type="checkbox"/> Building Lime <input type="checkbox"/> Natural building stones <input type="checkbox"/> Bricks <input type="checkbox"/> Tiles <input type="checkbox"/> Timber <input type="checkbox"/> Metal frames <input type="checkbox"/> Structural steel .....*	
	In what manner/ way have you used		
<b>2.3 NBC 102-1994 Unit Weight of Materials</b>			
	Where do you plan to apply NBC 102?	<input type="checkbox"/> Specifications <input type="checkbox"/> Design Calculation <input type="checkbox"/> Bill of Quantity	

	Specify the design unit weight of materials		
	Steel		
	Brick		
	RCC		
	Brick Masonry		

Note:\* If any materials other than specified in NBC 102-1994, the designer should take responsibility that such materials are according to international standard.

**2.4 NBC 103-1994 Occupancy load (Imposed Load)**

	Proposed occupancy type (fill in only concerning occupancy type)	Occupancy load		
		Uniformly Distributed load (kN/m <sup>2</sup> )	Concentrated Load (kN)	
	<u>For Residential Buildings</u>			
	Rooms and Kitchen			
	Corridors, Staircase, store			
	Balcony			
	<u>For Hotels, Hostels, Dormitories</u>			
	Living, Bed and dormitories			
	Kitchen, Corridors, Staircase			
	Store rooms			
	Dining, restaurants			
	Office rooms			
	.....			
	<u>For Educational Buildings</u>			
	Class rooms, Dining rooms			
	Kitchen			
	Stores			
	Libraries and archives			

	Balconies			
	.....			
	<u>For Institutional Buildings</u>			
	Bed rooms, wards, dressing rooms			
	Kitchen			
	X-ray rooms, operating rooms			
	Corridors and Staircase			
	Balconies			
	.....			
	<u>For Assembly Buildings</u>			
	Assembly areas			
	Projection rooms			
	Stages			
	Corridors, Passage and Staircase			
	Balconies			
	.....			
	<u>For Business and Office Buildings</u>			
	Rooms with separate storage			
	Rooms without separate storage			
	File rooms and storage rooms			
	Stair and passage			
	Balconies			
	.....			
	<u>Mercantile Buildings</u>			
	Retail shops			
	Wholesale shops			
	Office			
	Staircase and passage			
	Balconies			
	.....			

	<u>Industrial Buildings</u>			
	Work area without machinery			
	With machinery: Light duty			
	Medium duty			
	Heavy duty			
	Boiler			
	Staircase, Passage			
	<u>Storage buildings</u>			
	Storage rooms			
	Cold storage			
	Corridor and Passage			
	Boiler rooms			
<b>2.5 NBC 104-1994 Wind load</b>				
	Wind zone			
	Basic wind velocity		m/s	
<b>2.6 NBC 105-1994 Seismic Design of Buildings in Nepal</b>				
	Method of earthquake analysis:	<input type="checkbox"/> Seismic Coefficient method <input type="checkbox"/> Model Response Spectrum method <input type="checkbox"/> .....		
	Subsoil category			
	Fundamental transactions period			
	Basic seismic coefficient			
	Seismic zoning factor			
	Importance factor			
	Structural performance factor			
<b>2.7 NBC 106: 1994 Snow load</b>				
	Snowfall area	<input type="checkbox"/> Perennial <input type="checkbox"/> Occasional <input type="checkbox"/> No snowfall		
	Elevation			
	Design Depth			

	Design Density		
<b>2.8 NBC 107: 1994 Provisional Recommendation on Fire Safety</b>			
	Where do you plan to apply the fire safety requirements specified in NBC 107 and NBC 206-1994?	<input type="checkbox"/> Specifications <input type="checkbox"/> Design Calculation <input type="checkbox"/> Bill of quantity	
<b>2.9 NBC 108: 1994 Site Consideration for Seismic Hazards</b>			
	Distance from toe/beginning of downward slope		m
	Distance from river bank		
	Soil type in footing		
	Adopted safe bearing capacity		
	Type of foundation		
	Depth of foundation		
	Soil test report available?	<input type="checkbox"/> Yes <input type="checkbox"/> No	
<p>Note: Soil test is advisable for all professional engineered structures. In case, soil test is not carried out, the designer should take responsibility for assumed data concerning site consideration.</p>			
<b>2.10 NBC 109: 1994 Masonry: Unreinforced</b>			
	Concrete Grade		
	Brick crushing strength		
	Mortar ratio for load bearing masonry		
	<u>Floor</u> Ground floor First floor Second floor .....	<u>Wall height</u>	<u>Wall thickness</u>
	<u>Opening details:</u> Least distance from inside corner Does the total length of opening in any Wall exceed 50% of its length	<u>Maximum Length</u>	
		<input type="checkbox"/> Yes <input type="checkbox"/> No	

	Does the horizontal distance between any	<input type="checkbox"/> Yes	<input type="checkbox"/> No	
	Two opening less than 600 mm or ½ of			
	Height of shorter opening			
	Does the Vertical distance between two	<input type="checkbox"/> Yes	<input type="checkbox"/> No	
	Opening less than 600 mm or ½ of width			
	Of smaller opening			
	If any of above mentioned cases do not	<input type="checkbox"/> Yes	<input type="checkbox"/> No	
	Comply, do you have provision for			
	Strengthening around opening?			

	Bands provided:	<input type="checkbox"/> Plinth level <input type="checkbox"/> Lintel level	
		<input type="checkbox"/> Roof level <input type="checkbox"/> Gable band	
	Vertical steel reinforcement diameters at corner/tee joints:		
	Ground floor:		
	First floor:		
	Second floor		
	C/C distance of corner/tee strengthening Horizontal dower bars		

**2.11 NBC 110: 1994 Plain and Reinforced Concrete**

	Concrete grade		
	Reinforcement Steel Grade		
	Critical size of slab panel		
	Calculated short span to effective depth		
	Ratio (L/d) for corresponding slab		
	Permissible L/d ratio		
	Effective depth		
	Basic value of L/d		





	Design assumption:	<input type="checkbox"/> Simple connection <input type="checkbox"/> Semi-rigid connection <input type="checkbox"/> Fully rigid connection			
	Yield Stress:				
	Least wall thickness				
	Expose condition	Pipe	Webs of Standard size	Composed section	
	For Exposed Section For not exposed Section				
	Have you used Truss?	<input type="checkbox"/> Yes <input type="checkbox"/> No			
	What is the critical span of purlin				
	Purlin size				
	Have you used steel post?	<input type="checkbox"/> Yes <input type="checkbox"/> No			
	Slenderness ratio of the critical post				
<b>2.13 NBC: 112 Timber</b>					
	Name of structural wood:				
	Modulus of Elasticity:				
	Critical span of the beam element				
	Designed deflection				
	Slenderness ratio of the critical post				
	Joint type:				
<b>2.14 NBC: 113: 1994 Aluminium</b>					
	Have you used aluminium as structure member?	<input type="checkbox"/> Yes <input type="checkbox"/> No			
	If yes, please mention the name of design code.				
<b>2.15 NBC: 114 1994 Construction safety</b>					

	Are you sure that all safety measures will be fulfilled in the construction site as per this code?	<input type="checkbox"/> Yes <input type="checkbox"/> No	
	Safety wares use	<input type="checkbox"/> Safety hard hat <input type="checkbox"/> safety goggles <input type="checkbox"/> Safety boots <input type="checkbox"/> Safety belt <input type="checkbox"/> First aid facility	

**Affidavit**

I / We hereby certify that the proposed design of building and its various components comply all the requirements of prevailing National Building Code of Nepal. I/We also affirm that the submitted design is done by the concerned Engineers and Architects duly registered in Nepal Engineering Council. The data made available in this form are equally valid for all buildings apart from the main building.

Name: NEC No: Post: Name of Consulting Firm: Address: Date:	Seal:
--	-------

Technical Detail Form No. 2

For Class "C" Buildings

**Structural Design Requirements**

(To be filled by concerned Engineer or Consultant)

S.N.	Description	As per submitted design	Remarks
<b>1. General:</b>			
	Number of Storey		
	Total height of structure		
	Structure system	<input type="checkbox"/> Frame <input type="checkbox"/> Load bearing <input type="checkbox"/> Other	
	a) Provision for future extension b) If Yes - How many floors will be extended? c) Structural Design consideration for future extension	Yes      No  ..... Floors  Yes      No	
	In what manner/ way have you used		
<b>2.3 NBC 102-1994 Unit Weight of Materials</b>			
	Specify the design unit weight of materials Steel Brick RCC Brick Masonry		
Note:* If any materials other than specified in NBC 102-1994, the designer should take responsibility that such materials are according to international standard.			
<b>2.9 NBC 108: 1994 Site Consideration for Seismic Hazards</b>			
	Distance from toe/beginning of downward slope		m
	Distance from river bank		
	Soil type in footing		

	Adopted safe bearing capacity			
	Type of foundation			
	Depth of foundation			
	Soil test report available?	<input type="checkbox"/> Yes	<input type="checkbox"/> No	
<p>Note: Soil test is advisable for all professional engineered structures. In case, soil test is not carried out, the designer should take responsibility for assumed data concerning site consideration.</p>				
<b>2.10 NBC 109: 1994 Masonry: Unreinforced</b>				
	Concrete Grade			
	Brick crushing strength			
	Mortar ratio for load bearing masonry			
	<u>Floor</u> Ground floor First floor Second floor .....	<u>Wall height</u>	<u>Wall thickness</u>	<u>Maximum Length</u>
	<u>Opening details:</u>			
	Least distance from inside corner			
	Does the total length of opening in any Wall exceed 50% of its length	<input type="checkbox"/> Yes	<input type="checkbox"/> No	
	Does the horizontal distance between any Two opening less than 600 mm or 1/2 of Height of shorter opening	<input type="checkbox"/> Yes	<input type="checkbox"/> No	
	Does the Vertical distance between two Opening less than 600 mm or 1/2 of width Of smaller opening	<input type="checkbox"/> Yes	<input type="checkbox"/> No	
	If any of above mentioned cases do not Comply, do you have provision for Strengthening around opening?	<input type="checkbox"/> Yes	<input type="checkbox"/> No	
	Bands provided:	<input type="checkbox"/> Plinth level	<input type="checkbox"/> Lintel level	
		<input type="checkbox"/> Roof level	<input type="checkbox"/> Gable band	

	Vertical steel reinforcement diameters at corner/tee joints:  Ground floor: First floor: Second floor		
	C/C distance of corner/tee strengthening Horizontal dower bars		

**2.11 NBC 110: 1994 Plain and Reinforced Concrete**

	Concrete grade		
	Reinforcement Steel Grade		
	Critical size of slab panel		
	<b>Beam Characteristics</b>	Condition of beams	
		Canti- Lever	Simply Supported
		One side Continuous	Both side Continuous
	Maximum span/depth ratio		
	Span of corresponding beam		
	Depth of corresponding beam		
	Width of corresponding beam		

**2.15 NBC: 114 1994 Construction safety**

	Are you sure that all safety measures will be fulfilled in the construction site as per this code?	<input type="checkbox"/> Yes <input type="checkbox"/> No	
	Safety wares use	<input type="checkbox"/> Safety hard hat <input type="checkbox"/> safety goggles <input type="checkbox"/> Safety boots <input type="checkbox"/> Safety belt <input type="checkbox"/> First aid facility	

**Affidavit**

I / We hereby certify that the proposed design of building and its various components comply all the requirements of prevailing National Building Code of Nepal.

Name: Post: Name of Consulting Firm: Address: Date:	Seal:
---	-------

Schedule 2

(Relating to Rule 5)

Fee for Getting a copy of the Building Code

1. Seven hundred rupees for a hard copy of the Building Code (per piece)
2. One hundred fifty rupees for a digital copy of the Building Code (per C.D.)

### **Annex III: Submittals for getting Building permit**

#### **A. List of the documents to be submitted for getting permit for new construction**

<b>S.N.</b>	<b>Descriptions of the documents required</b>	<b>No. of copies</b>
1.	Drawings showing elevations, sections, plans, details and site plans of the building in the prescribed format with the signature of the Designer & the Building Owner	5 copies
2.	Structural design report (for Category A & Category B Buildings only)	1 copy
3.	Electrical drawings and details (for Category A & Category B Buildings only)	3 copies
4.	Sanitary drawings and details (for Category A & Category B Buildings only)	3 copies
6.	Soft Copy of Structural Analysis File (for Category A & Category B Buildings only)	
7.	Attested copies of the land ownership certificate	1 copy
8.	Copy of the receipt showing payment of land tax in case there is no any building in the land parcel and copy of the receipt of the payment of integrated property tax in case there is already other building in the land parcel or new storey is to be added to the existing building of the current fiscal year	1 copy
9.	Attested copy of the citizenship certificate of the building owner	1 copy
10.	Copy of the cadastral map showing the land plot number	1 copy
11.	Copy of the registration certificate of the designer	1 copy
12.	Passport size photo of the applicant	3 copies
13.	Copy of the land registration form and land transfer paper	1 copy
14.	If the access road to the building site has not been shown in the cadastral map, recommendation letter from the Ward Office verifying the existence of the access road in the field. If the land parcel is a Guthi land, recommendation letter from Guthi Sansthan verifying the existence of the access road.	
15.	If the land parcel is a Guthi land, permission letter from the Guthi Sansthan for the construction of the building. Also, if the landowner of such land	

	parcel wants to construct the building, permission letter from the Mohi. If the Mohi wants to construct the building, permission letter from the land owner is required.	
16.	If the land parcel is in mortgage in some financial institution, authorization letter from the institution for the construction of the building.	
17.	For the construction of institutional/ commercial building, following additional documents are required to be submitted: a) Copy of the Company Registration Certificate b) Copy of the VAT/PAN Registration Certificate c) Copy of the Memorandum of Association & Articles of Association of the Company d) Copy of the Business Registration Certificate in the Municipality e) Copy of the Minute of Meeting for the Construction of the Building	

**B. List of the documents to be submitted for getting permit for new construction after demolishing old building**

Documents required are the same as the ones required for new construction

**C. List of the documents to be submitted for getting permit for the addition of new storeys or new blocks**

S.N.	Descriptions of the documents required	No. of copies
1.	All documents required for getting building permit for new construction	3 copies
2.	Copies of the approved drawings and details of old building obtained after getting the building permit. Such drawings shall include all floor plans, all elevations, sectional elevations, site plans and structural detailed drawings.	1 copy
3.	Copies of the Permanent Building Permit of the original building	1 copy
4.	Building construction completion certificate/ partial completion certificate	1 copy
5.	Receipt or voucher showing payment of the building & land tax to the municipality till this fiscal year	1 copy
6.	Photographs showing existing condition of the old building	1 copy

**D. List of the documents to be submitted for getting permit for the alteration of the façade of the existing building or for changing the roof**

S.N.	Descriptions of the documents required	No. of copies
------	--	---------------



1.	Building Permit Certificate and approved copies of the drawings of the building	3 copies
2.	Plans & elevations of the existing façade or roof along with the plans & elevations of the proposed façade or roof.	3 copies

**E. List of the documents to be submitted for getting permit for the erection of compound wall, temporary construction or others**

S.N.	Descriptions of the documents required	No. of copies
1.	All documents required for getting building permit for new construction	3 copies

**F. List of the documents to be submitted for the transfer of the building permit in the name of new building owner**

S.N.	Descriptions of the documents required	No. of copies
1.	Application letter requesting transfer of the building permit in the name of the new owner	1 copy
2.	Copy of the land ownership certificate	1 copy
3.	Copy of the certificate issued by the land revenue office showing transfer of the ownership of the property	1 copy
4.	Original copies of the building permit, designs and drawings issued by the municipality in the name of the original owner	3 copies
5.	Copy of the receipt showing payment of the land tax & property tax up to the current fiscal year.	1 copy
6.	Photograph of the building already constructed.	1 copy
7.	Copy of the Building Construction Completion Certificate	1 copy
8.	Any other supporting documents requested by the municipality	1 copy



## Annex IV: Checklist for Field Inspection

### Check List for Field Inspection

(BUILDING CODE IMPLEMENTATION PROCESS)

#### I. General

S. No	Description	Observation in the Field	Remarks
1.	Classification of Building as per NBC	<input type="checkbox"/> A <input type="checkbox"/> B <input type="checkbox"/> C <input type="checkbox"/> D	
2.	Functional Use of Proposed Building	<input type="checkbox"/> Residential <input type="checkbox"/> Commercial <input type="checkbox"/> Others.....	
3.	Plinth Area in Sft.		
4.	No. of Storey of Proposed Building		
5.	Total Height of Proposed Building		
6.	Soil type in Foundations		
7.	Adopted Safe Bearing Capacity of soil		
8.	Concrete Grade used for i) Foundations ii) Columns iii) Tie Beams iv) Beam/Slab		
9	Reinforcement Steel Grade		

S. No	Description	Observation in the Field	Remarks
10	Is the building located in unstable ground? If yes, what type of hazard is there?	<input type="checkbox"/> Vulnerable buildings in neighborhood <input type="checkbox"/> Pounding effect <input type="checkbox"/> Access	
11	Site safety issues?	<input type="checkbox"/> Materials placement <input type="checkbox"/> General safety requirements followed <input type="checkbox"/> Dangerous material e.g. reinforcement bars, nails thrown here and there ?	
12	Structural System of Proposed Building	<input type="checkbox"/> RCC Frame Structure <input type="checkbox"/> Load Bearing Wall System <input type="checkbox"/> Others (Specify.....)	

## II. Materials

S. No	Description	Observation in the field	Remarks
1	Sand: Storage Water content General Quality		
2	Brick: Brick quality Cleanliness Water absorption		
3	Cement: Storage Purchased date		
4	Aggregates: Grading Cleanliness		

S. No	Description	Observation in the field	Remarks
	Shape		
5	Reinforcement bar: Quality Rust and physical condition		

### III. Construction

S. No	Description	According to Actual Construction in Site	Remarks
1	Concrete mix: Ratio Procedure for concrete mixing Water cement ratio Is strength check done?		
	Placement of concrete: Pouring of concrete Compaction Shear key in column		
	Framework/ Centering/ Shuttering: Quality Safety		
	Curing: Done properly?		
	Reinforcement Bending Fabrication		

	Placement		
	Detailing Stirrups Beam/column joint Lap length		
	General Eccentricity Member Connectivity		

#### IV. For RCC Frame Structure

S. No	Description	According to Municipal Approval Drawing	According to Actual Construction in Site	Justification for variations
1	Foundation Details i) Depth ii) Sizes with naming: a. Corner b. Mid c. Face d. Others ..... ..... ..... iii) Reinforcements dia & spacing for foundations a. Corner b. Mid c. Face d. Others ..... ..... .....			
2	Column Details i) Height from G. L. to Tie Beam Level (Plinth Height) ii) Floor Height			

S. No	Description	According to Municipal Approval Drawing	According to Actual Construction in Site	Justification for variations
	iii) Sizes with naming: a. Corner b. Mid c. Face d. Others ..... ..... ..... iv) Reinforcements with naming a. Corner b. Mid c. Face d. Others ..... ..... v) Stirrups dia. and Spacing			
3	Earthquake safety features Follows? <ul style="list-style-type: none"> <li>• Ties at Joint</li> <li>• Development length / Lap length</li> </ul>			
4	Combined Footing Details (if provided) i) Size ii) Reinforcements: Top Jali Bottom Jali			



S. No	Description	According to Municipal Approval Drawing	According to Actual Construction in Site	Justification for variations
5	Lower footing Tie Beam (If Provided) i) Size iii) Reinforcement Details iv) Stirrups dia. and Spacing			
6	Plinth Tie Beam i) Size iii) Reinforcement Details iv) Stirrups dia. and Spacing			
7	Column Placing are in Grid?			
8	Quality of Workmanship?			
<b>Other Comments (if any)</b>				

## References

1. Nepal Urban Road Standard, DOR 2019
  2. The Building Act of Nepal, MOUD 1999
  3. The Building Regulations of Nepal, MOUD, 2009
  4. Indigenous Knowledge and Technologies for Safer Buildings, UNDP/ERRRP, 2010
  5. Local Government Operations Act, MOFAGA 2017
  6. Basic Standards on Settlement Development, Urban Planning & Building Construction, MOUD, 2015
  7. Nepal National Building Codes, MOUD/DUDBC, 1994, 2015, 2020
  8. Handbook, Building Code Implementation, Learning from Experience of Lalitpur Sub-Metropolitan City, Nepal, LSMC/UNCRD, 2008
  9. The Environment Protection Act, MOFP, 2019
  10. Environmental Protection Guidelines, MOFP in 2020
  11. Standard Norms and Specification for CESB Blocks, Ministry of Education, Science and Technology, 2012,
  12. Stone-Crete Block Making Manual, Habitat for Humanity Nepal
  13. National Urban Development Strategy 2017, MOUD
- Coverage Photo Source: myRepublica- Nagarik Network